

LFDC

LAMINAR FLOW DIFFUSER WITH HEPA FILTER



HOLYOAKE
AIR MANAGEMENT SOLUTIONS | by price

price | **CRITICAL ENVIRONMENTS**

LFDC

Laminar Flow Diffuser with HEPA Filter

The Laminar Flow Diffuser with HEPA Filter has been designed to suit the stringent requirements of modern operating rooms and other clean spaces. The LFDC provides a means of controlling particle concentration within a room by providing unidirectional laminar airflow with low initial face velocity, supplying clean air to the space without entrainment of contaminated air from the occupied space.

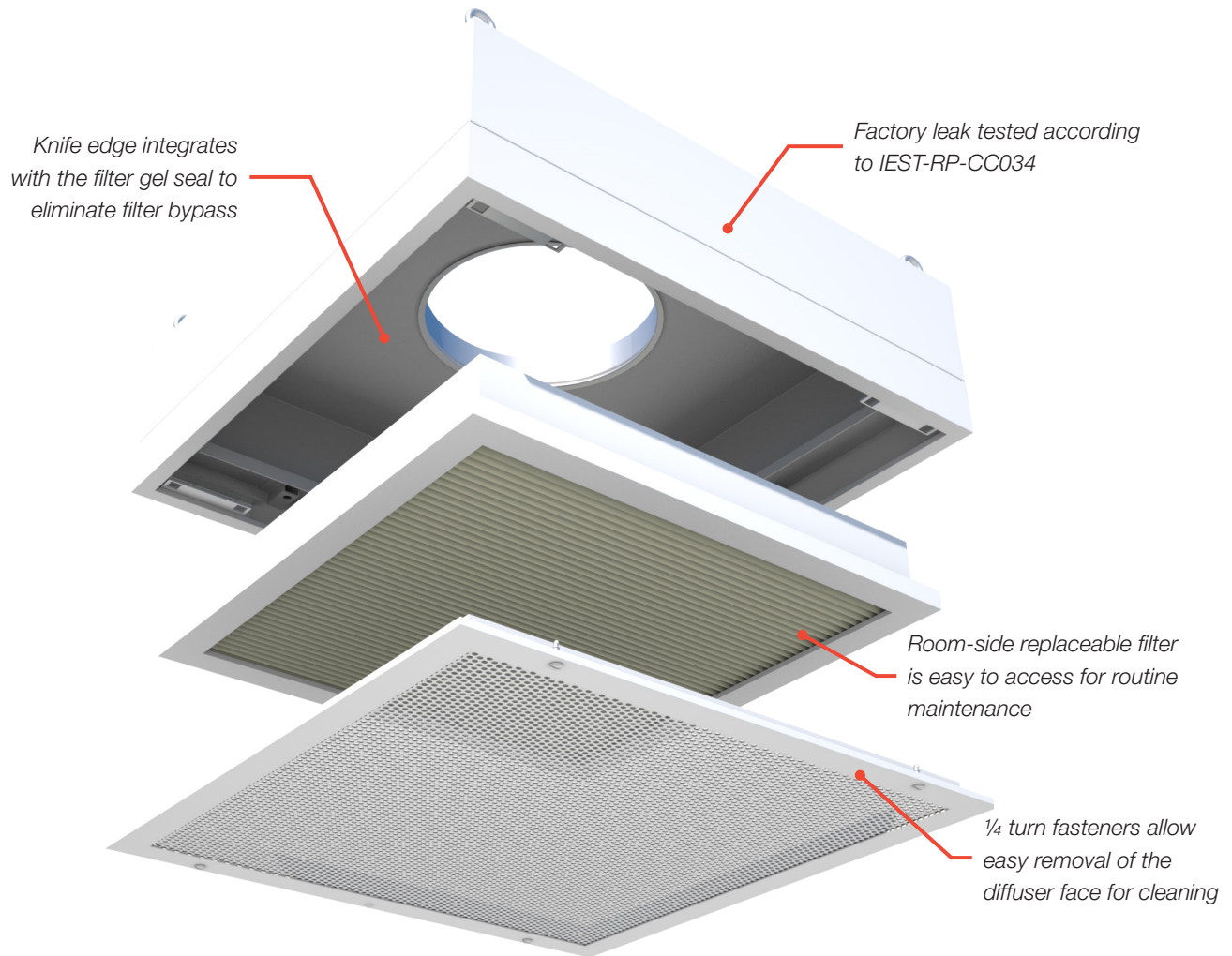

LFDC

Laminar Flow Diffuser with HEPA Filter

ROOM-SIDE REPLACEABLE FILTER

- + Convenient access from the room-side for periodic filter replacement.
- + Gel seal filter frame and diffuser “knife edge” flange create a reliable seal to prevent filter bypass.
- + Factory supplied HEPA filter removes 99.995% of particulate.

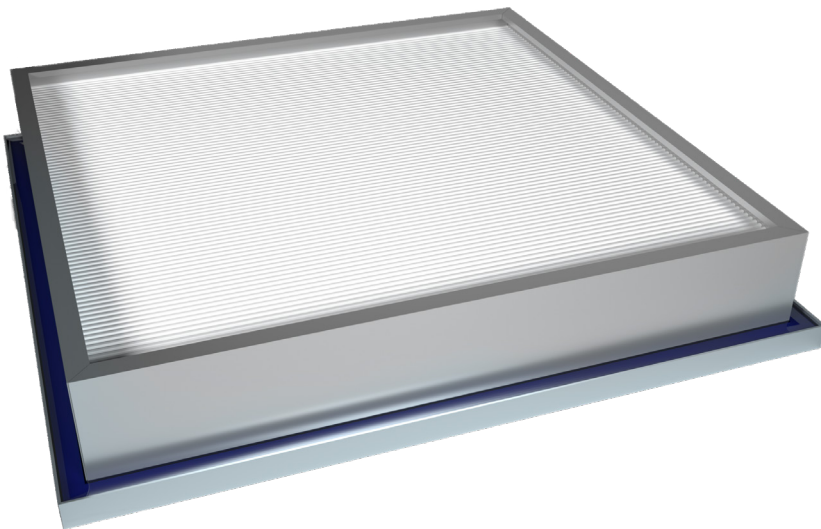

FACTORY LEAK TESTING AND CERTIFICATION

- + Every LFDC is factory tested and certified leak-free in accordance with IEST-RP-CC034.

CLEANING & MAINTENANCE

- + LFDC units satisfy all ASHRAE 170 requirements for diffuser cleaning and maintenance.
- + Powder coat paint finish is formulated for routine exposure to hospital grade cleaning solutions and disinfectants.
- + ¼ turn fasteners and retainer cables provide straightforward and convenient access to the filter and knife-edge frame.

TYPICAL APPLICATIONS

The LFDC is classified as an ASHRAE group E non-aspirating diffuser and meets all ASHRAE 170 performance and construction requirements. LFDC diffusers are required by code or commonly used in Operating Rooms, Laboratories, Pharmacies, Pharmaceutical Manufacturing facilities, Cleanrooms and other critical spaces.

CONSTRUCTION

- + Material
 - Aluminium
 - Stainless steel
- + Standard
 - Aerosol test system
 - Equalisation basket
- + Optional
 - LED filter status indicator
 - Room-side adjustable damper
 - Casing insulation

LED FILTER STATUS INDICATOR

- + An optional LED filter status light, visible from the room-side, changes from green to yellow when the filter is loaded and due for replacement.
- + The LED light is factory calibrated to trigger once the filter pressure drop has increased by 50% above that of an unloaded filter and can be adjusted in the field to suit facility preferences.



ROOM-SIDE ADJUSTABLE DAMPER

- + An optional remote cable operator allows adjustment of the damper with the filter in place.
- + Locating the damper operator outside of the filter maximises filter area, leading to a larger airflow capacity and less pressure drop.

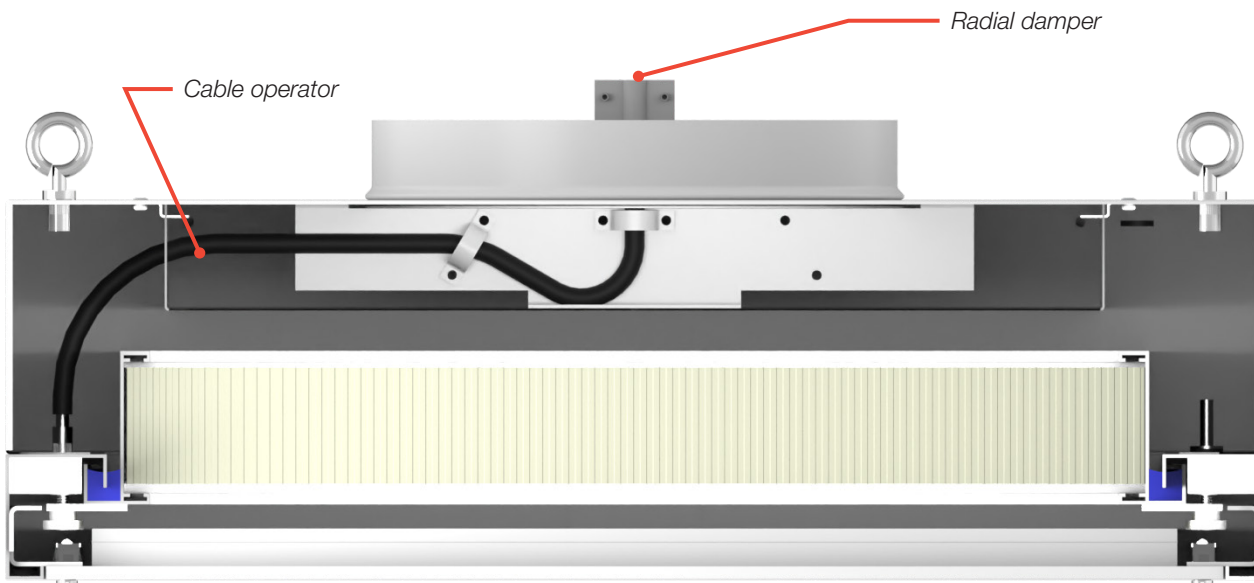

Room-side adjustable damper cross sectional view

EQUALISATION BASKET

- + The equalisation basket, located beneath the inlet, equalises airflow and ensures even loading across the filter.

AEROSOL SAMPLE & STATIC PRESSURE PORT

- + Used for room-side field measurement of static pressure and challenge aerosol concentrations upstream of the filter during the commissioning process.

AEROSOL TEST SYSTEM

- + Unique and convenient option when upstream aerosol injection during field commissioning is impractical.
- + The barbed aerosol injection port for 1/2 in. ID tubing and aerosol sample and static pressure port facilitate the complete room-side aerosol challenge of the diffuser.
- + Stainless steel aerosol dispersion ring for equalised aerosol challenge across the entire active filter area.

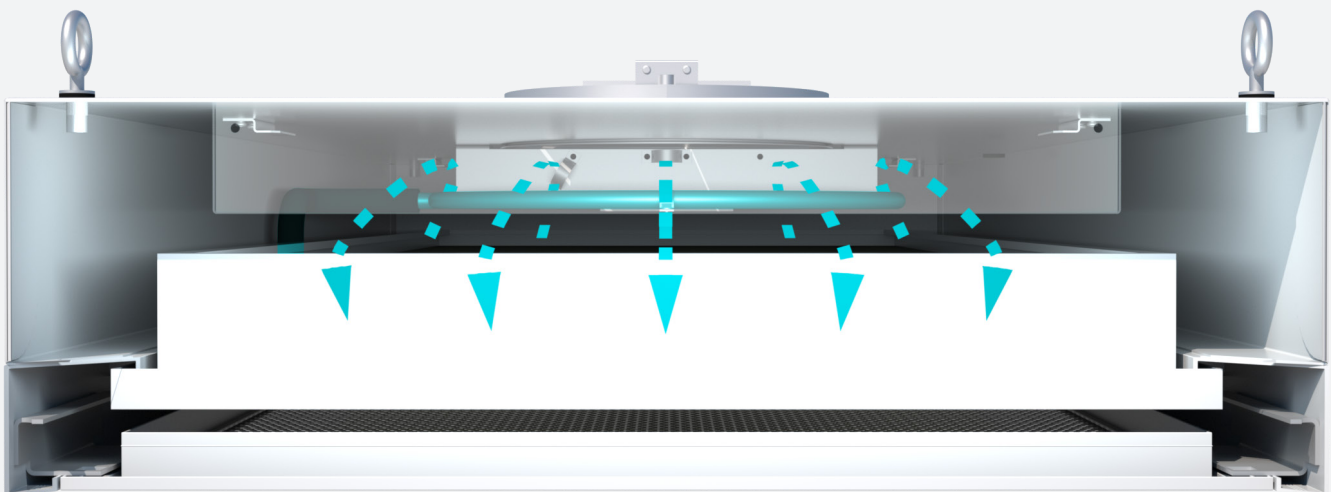

FACTORY INSTALLED INSULATION

- + Ensures quality application and minimises field labour with factory installed insulation
- + Minimises condensation risk associated with unconditioned plenum air exposure to cold diffuser surfaces
- + Reduces thermal gain for improved energy savings

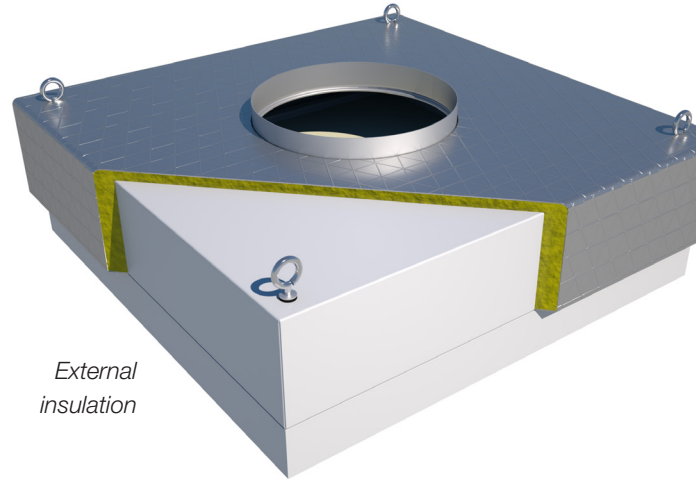

External insulation



DIMENSIONAL DATA

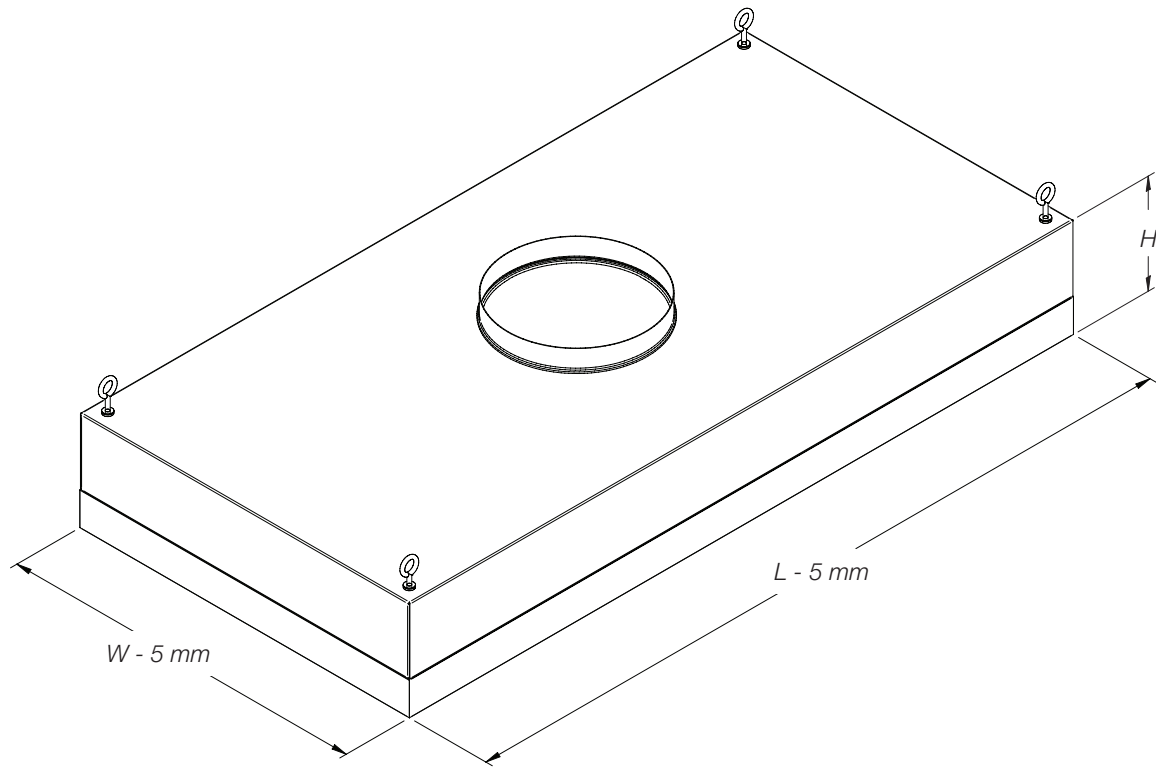

Nominal Unit Size (W x L)	Actual Width	Actual Length	Inlet Sizes	Height
600mm x 600mm	595mm	595mm	(145, 195, 245, 295) mm	175mm
690mm x 690mm	685mm	685mm	(145, 195, 245, 295) mm	189mm
600mm x 900mm	595mm	895mm	(145, 195, 245, 295) mm	175mm
690mm x 995mm	685mm	990mm	(145, 195, 245, 295) mm	189mm
600mm x 1200mm	595mm	1195mm	(195, 245, 295) mm	175mm
690mm x 1300mm	685mm	1295mm	(195, 245, 295) mm	189mm

PERFORMANCE DATA

Metric

Unit Size (mm)	HEPA Filter Size (mm)	Air Flow (L/s)	Filter	Static Pressure (Pa)	Sound (NC)
600 x 600	520x520x65	47	HEPA 99.995% 0.3µm	46	-
		71		96	-
		94		120	-
		118		158	-
		47	ULPA 99.9995% 0.12µm	81	-
		71		126	-
94	169	-			
118	214	-			
685 x 685	610x610x80	47	HEPA 99.995% 0.3µm	41	-
		71		61	-
		94		80	-
		118		100	-
		167		140	-
600 x 900	520x820x65	71	HEPA 99.995% 0.3µm	40	-
		94		63	15
		118		86	19
		142		109	23
		165		132	27
		189	154	30	
		71	ULPA 99.9995% 0.12µm	80	-
		94		99	15
		118		127	19
		142		154	23
165	180	27			
189	207	30			
685 x 990	610x915x80	94	HEPA 99.995% 0.3µm	54	-
		118		67	-
		142		80	18
		165		93	21
		189		106	24
250	140	30			
600 x 1200	520x1120x65	94	HEPA 99.995% 0.3µm	37	-
		142		70	-
		189		103	-
		236		135	17
		283		168	23
		94	ULPA 99.9995% 0.12µm	71	-
		142		110	-
		189		148	-
		236		185	17
		283		223	23
685 x 1295	610x1220x80	142	HEPA 99.995% 0.3µm	61	-
		189		80	-
		236		100	-
		283		119	15
		333		140	20

Performance Notes:

1. SP = Static Pressure in Pascals, Pa.
2. L/s = Air flow in Liters per second, L/s.
3. NC = Noise Criteria. NC values are based on room absorption of 10dB re 10⁻¹² watts.
4. Blanks "-" indicate an NC level below 15.
5. SP and NC at full open damper position.
6. Pressure drop: ± 15%.
7. NC values listed here are based on the equivalent imperial size.

HOLYOAKE
AIR MANAGEMENT SOLUTIONS | by price

price | **CRITICAL ENVIRONMENTS**

Product Improvement is a continuing endeavour at Holyoake. Therefore, specifications are subject to change without notice. Consult your Sales Representative for current specifications or more detailed information. Not all products may be available in all geographic areas.