

RAC

RETURN AIR CANOPY



HOLYOAKE
AIR MANAGEMENT SOLUTIONS | by **PRICE**

PRICE | **NOISE CONTROL**

RAC

Return Air Canopy

Lightweight and easy to install, this innovative product provides an economical solution for return air noise and improved speech privacy. Positioned directly above return grilles, the RAC prevents the transfer of occupant noise into the plenum above and prevents mechanical noise in the plenum from flanking through return grilles, or open vents, into the occupied space below.

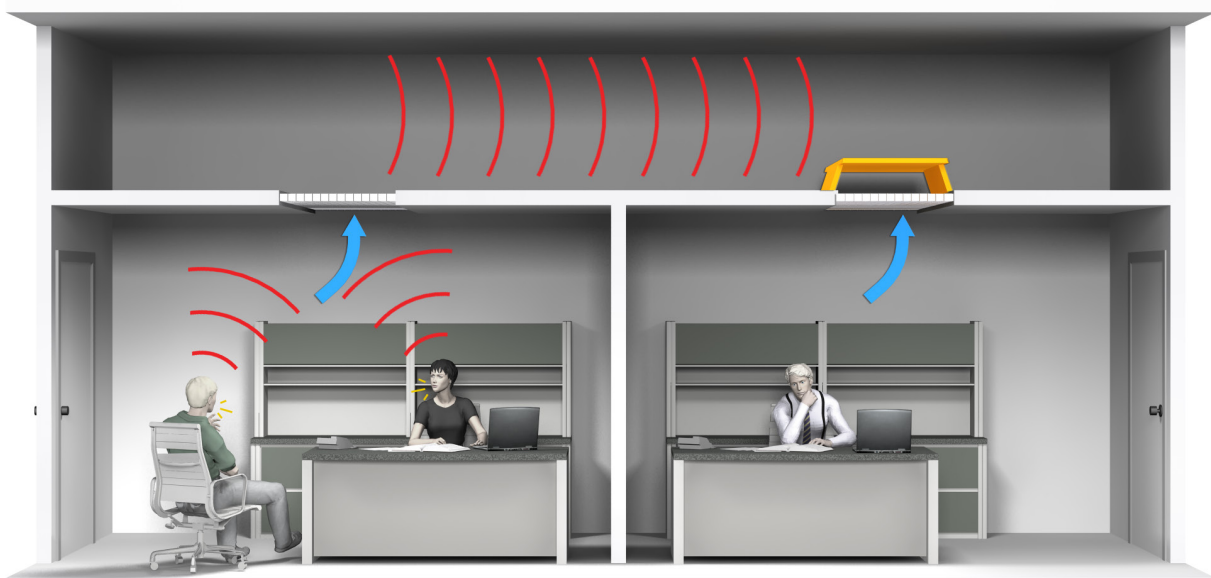
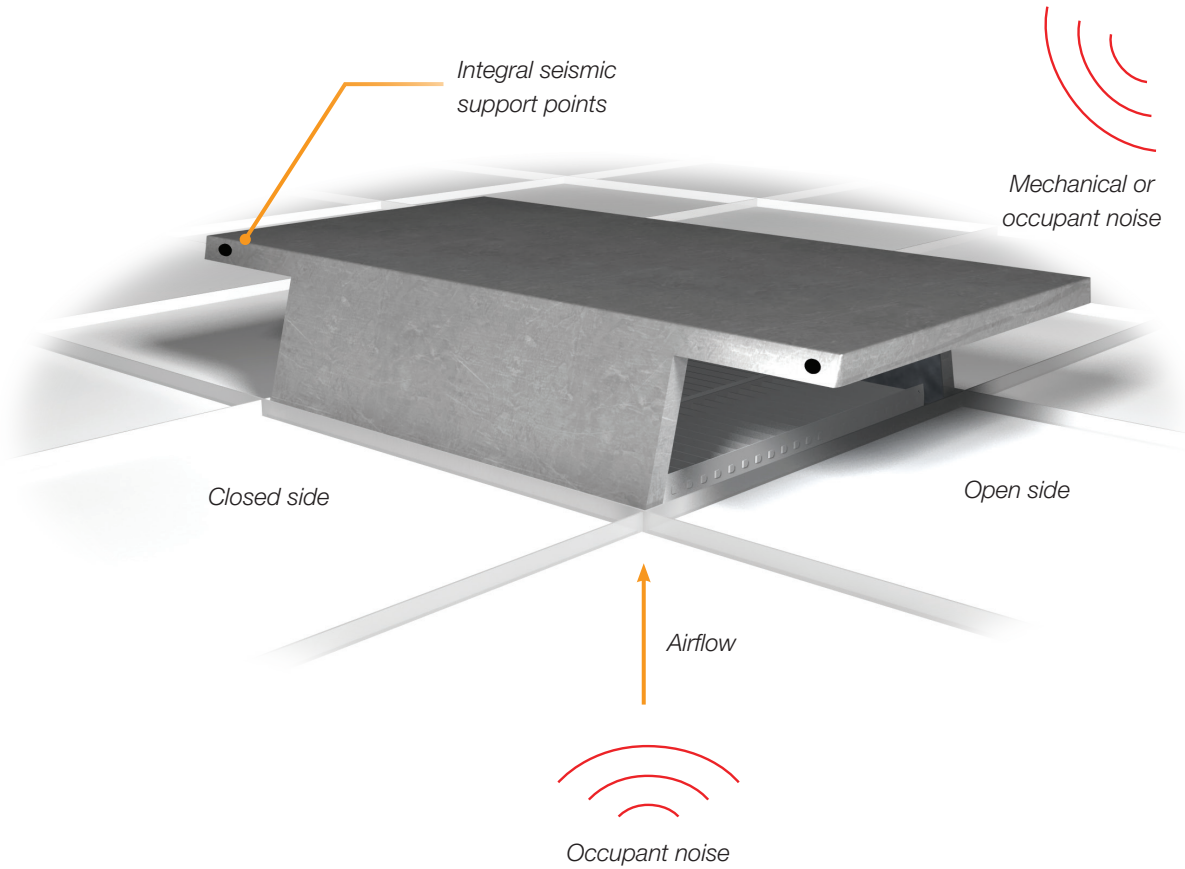

ENGINEERED PERFORMANCE

- + The laboratory tested design allows for return air to flow through with minimal pressure drop and maximum noise attenuation. For optimal performance, the RAC should be used in applications with velocities below 2.5 m/s, or 945 l/s for a typical 600 mm x 600 mm return grille.

REDUCED PLENUM VISIBILITY

- + Located directly above return grilles, the RAC reduces visibility into the plenum and reduces light transfer through the plenum into the room below.

DESIGN FLEXIBILITY

- + The RAC is available with fiberglass or fiber free foam liners to best suit varying project requirements.
- + Multiple paint and return grille options allow the RAC to meet a variety of aesthetic requirements
- + With a unit depth of only 175 mm, the RAC can be easily incorporated in any ceiling plenum without contributing to congestion within the space.

EASY INSTALLATION

- + Designed specifically for ceiling applications the RAC is available in standard grille sizes and fits easily onto standard ceiling grids.

FIRE RATED

- + Class 1 index: flame/smoke < 25/50
- + ASTM E84, UL 723, NFPA 255

TYPICAL APPLICATIONS

The RAC provides a low cost solution for improving speech privacy between adjoining spaces while allowing for maximum airflow through the return grille. The most common applications for acoustical ceiling tile return air plenums are in office and retail spaces.

OPTIONS

- + Acoustic Media
 - Fiberglass
 - Fiber free foam
- + Material
 - Galvanized Steel
 - Galvanneal
 - Stainless Steel
 - Aluminium
- + Finish
 - Black powder coat



DIMENSIONAL DATA

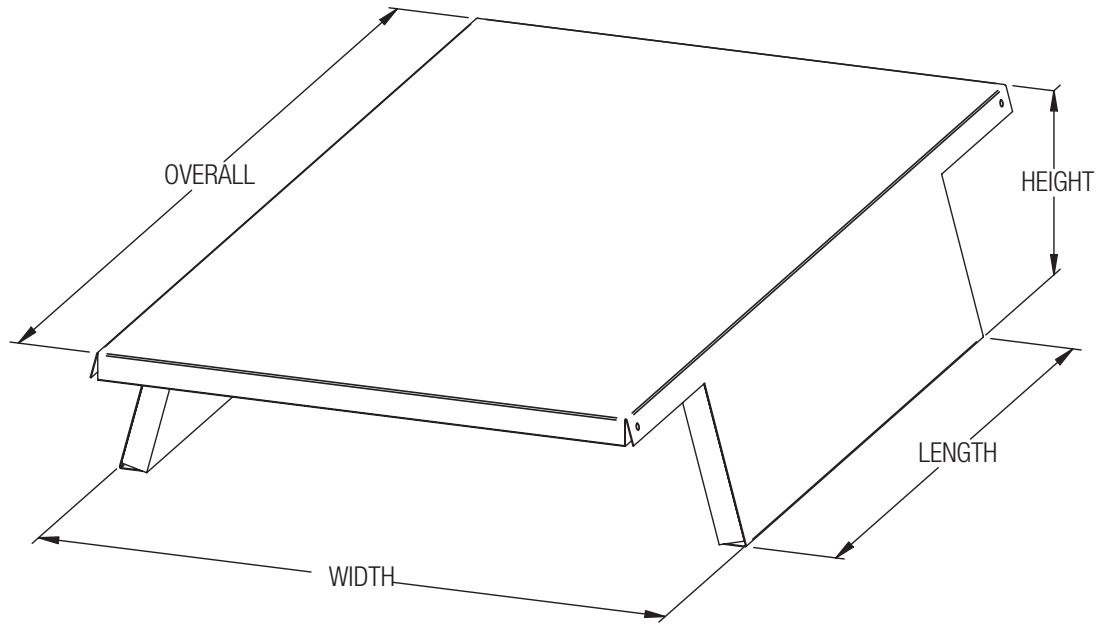

Standard Dimensions

W - Width	L - Length	H - Height
300	300	175
300	600	175
600	600	175
600	1200	175

1. All dimensions are in millimetres.
2. For sizes outside the standard range, please contact your local Holyoake Sales office.
3. All dimensions are nominal.

PERFORMANCE DATA

Recommended Air Velocity Range

Model	Description	Air Velocity Range (m/s)
RAC	Return Air Canopy	0 - 2.5

Noise Reduction (dB)

Model	Octave Band Center Frequencies (Hz)							
	63	125	250	500	1k	2K	4K	8K
RAC	8	10	11	12	20	20	22	25

Pressure Drop (Pa)

Model	Face Velocity (m/s)	0.5	1.0	1.5	2.0	2.5
RAC	Pa	3	8	20	35	55

Performance Notes:

1. Data tables are derived from test data in conformance with ASTM E477-20 with the specimen located at the opening to the reverberation chamber.
2. Velocity based on cross-sectional grille area (W x H)
3. Performance data based on a 600 mm x 600 mm unit.



Product Improvement is a continuing endeavour at Price. Therefore, specifications are subject to change without notice. Consult your Price Sales Representative for current specifications or more detailed information. Not all products may be available in all geographic areas. All goods described in this document are warranted as described in the Limited Warranty shown at priceindustries.com. The complete Price product catalog can be viewed online at priceindustries.com.