

# PURAFLO®

CLEANROOM TECHNOLOGIES FOR COMMERCIAL APPLICATIONS



The Puraflo provides HEPA filtration and increased room air changes, effectively reducing the concentration of, and therefore the probability of exposure to, airborne pathogens<sup>1</sup> and other contaminants. Ideal for use in a variety of commercial spaces including offices, classrooms and more; the Puraflo is quick and easy to install with no impact on the existing HVAC system. Derived from our industry leading line of Fan Filter Units (FFU) the Puraflo delivers cleanroom-grade HEPA filtration with high energy efficiency and low sound levels.

<sup>1</sup>Removal of 99.9% of airborne Phi-X174 (virus), A. niger (mold), and P. citrinum (fungus) was demonstrated by third-party laboratory within 30 minutes when Puraflo was operated at minimum air flow setting (254 CFM), or within 15 minutes if operated at maximum airflow setting (750 CFM), in a 10'x10'x10' room at ambient temperature and humidity.

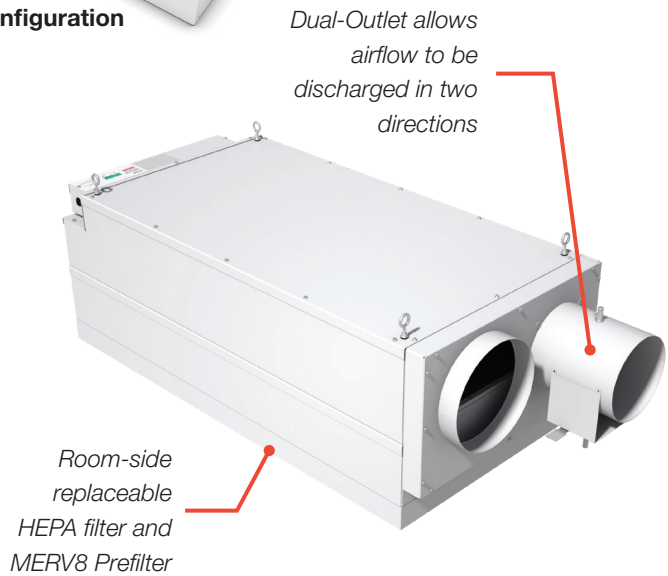
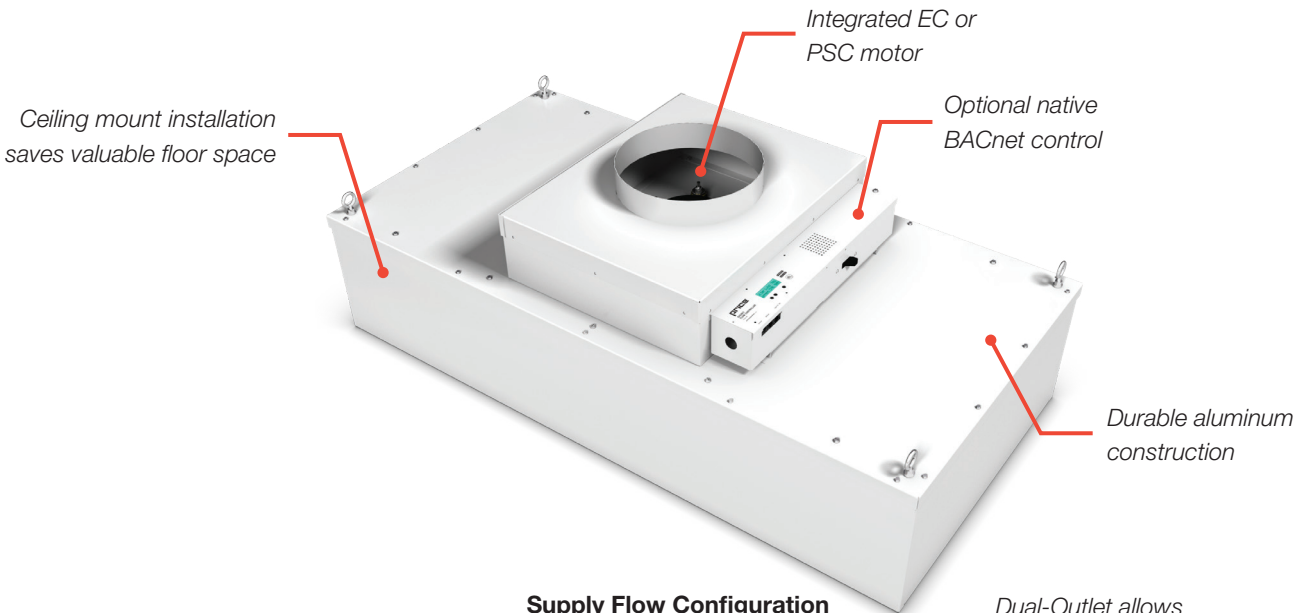

## ULTRA-CLEAN AIRFLOW

- + Puraflo is third-party lab verified to remove up to 99.9% of airborne pathogens under the specified conditions of use.<sup>1</sup>
- + HEPA filtration can be used to increase the air change rate in any space to reduce the concentration of airborne pathogens<sup>1</sup> and other contaminants.

## APPLICATION FLEXIBILITY

- + Ideal for retrofit applications, Puraflo is simple to install and functions completely independently of the existing HVAC system, eliminating the need for costly infrastructure changes while providing ultra-clean recirculated airflow.
- + Ceiling-mount configurations free up valuable floor space, and allow the Puraflo to be located throughout the ceiling to optimize removal of pathogens<sup>1</sup> and other contaminants. For ease of installation, the Puraflo is sized to fit standard t-bar ceiling grid.
- + For location flexibility, and even faster installation portable floor-mount options are available.

## TYPICAL APPLICATIONS

The Puraflo is intended for a wide range of applications wherein HEPA filtration is desired or required to reduce airborne pathogens<sup>1</sup> and other contaminants. A variety of construction options allow this versatile product to be configured for a multitude of retrofit applications including dental clinics, patient rooms, personal care homes, offices, classrooms, and more.

## CONSTRUCTION

- + Configuration
  - Supply flow
  - Reverse flow
  - Dual-outlet reverse flow
- + Mounting
  - Ceiling
  - Portable cart
- + Size
  - 24 in. x 24 in.
  - 24 in. x 36 in.
  - 24 in. x 48 in.
- + Options
  - Face-mounted LED indicator
  - Power cord
  - Ultraviolet light
  - Bipolar ionization



## Flexible Mounting

- + For HEPA-filtered air fast, temporarily use Puraflo in a floor mount configuration, and later have the same unit ceiling mounted for a permanent clean air solution.



### Reverse Flow Configuration

- + Contaminated room air is drawn in through the face of the unit, passed through the HEPA filter, and recirculated to the space through a standard ceiling diffuser.
- + This configuration allows selection of the discharge diffuser to optimize thermal comfort and air distribution in the space.

### Dual-Outlet Reverse Flow Configuration

- + Contaminated room air is drawn in through the face of the unit, passed through the HEPA filter, and discharged through two outlets - one ducted to the outdoors, and the other to a supply diffuser recirculating filtered air to the space.
- + This configuration is ideal for applications like dental offices and patient rooms where a negative room pressure as well as an increased air change rate is desired.

### Supply Flow Configuration

- + Contaminated room air is drawn in through the inlet on the back of the unit or a standard return grille, passed through the HEPA filter, and redistributed to the space with a laminar airflow pattern.
- + This configuration is well suited to:
  - Small rooms or offices where additional mixing diffusers cannot be accommodated
  - Atriums with high ceilings, where a downward column of air is advantageous
  - Non-ducted applications like open ceilings or floor mount configurations

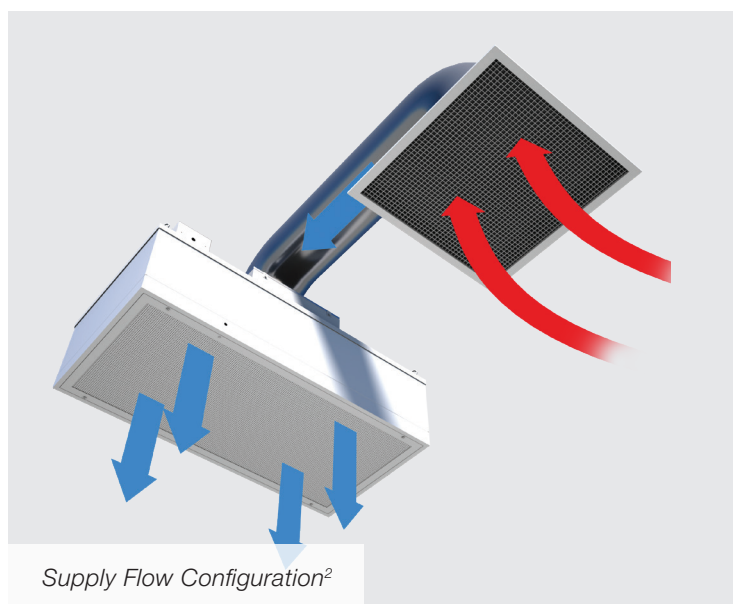
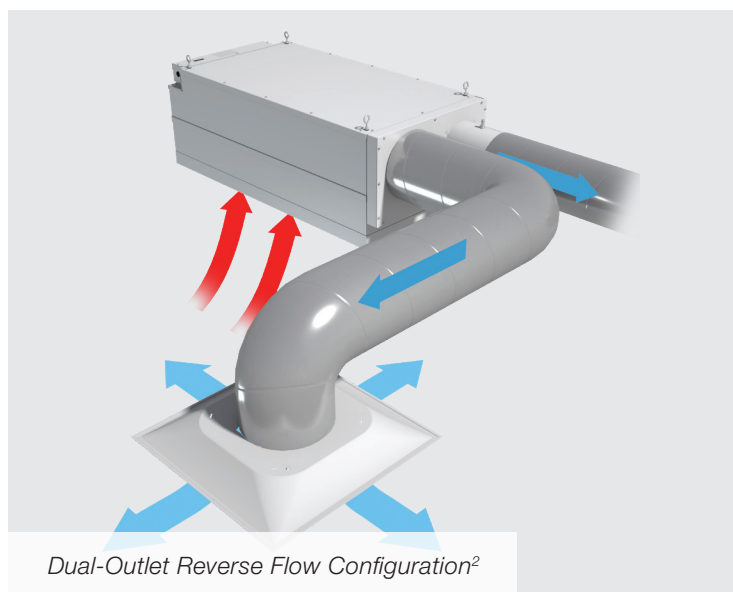
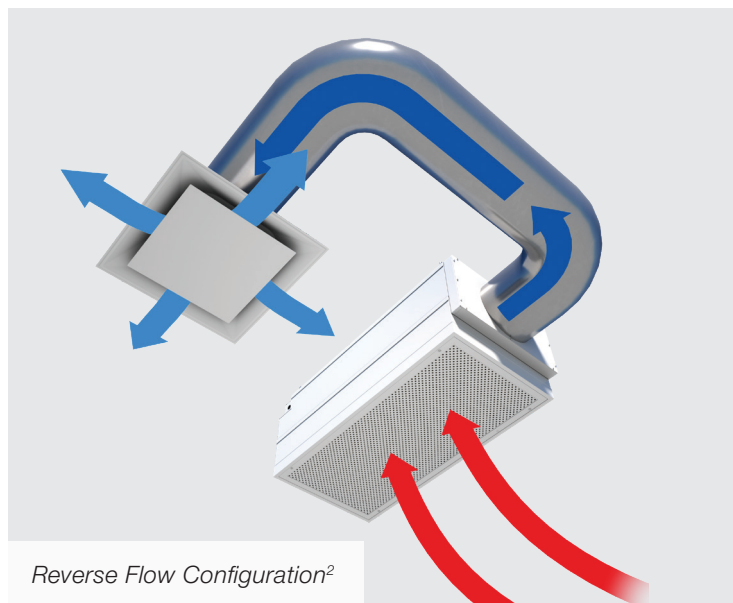

<sup>2</sup>Note: Puraflo and supply diffuser are shown close together for illustrative purposes. This image is not an installation recommendation.

## CLASSROOM

### Room Specs

- + Room Size: 1000 ft<sup>2</sup>
- + Ceiling Height: 9 ft.
- + Room Volume: 9000 ft<sup>3</sup>
- + Additional Air Changes: 2
- + Flow Rate: 300 cfm
- + Sound: <35 NC
- + Equipment:
  - 1x Puraflo Reverse Flow (24 in. x 48 in.)
  - 1x Supply Diffuser

### Details

Puraflo can be used in schools and classrooms to increase the air change rate (ACH) and reduce the concentration of airborne pathogens<sup>1</sup> and other contaminants.

A typical classroom is approximately 1,000 ft<sup>2</sup> with 9 ft. ceilings. One reverse flow Puraflo (24 in. x 48 in.) can supply two additional air changes to a classroom with a flow rate of 300 cfm.

The Puraflo and the corresponding supply diffuser should be positioned for maximum removal of airborne pathogens<sup>1</sup> and other contaminants in the space, and to avoid filtered air discharging directly into the Puraflo. Selection of the discharge diffuser should promote room air mixing and thermal comfort.





## OPEN OFFICE

### Room Specs

- + Room Size: 1200 ft<sup>2</sup>
- + Ceiling Height: 10 ft.
- + Room Volume: 12,000 ft<sup>3</sup>
- + Additional Air Changes: 2
- + Flow Rate: 400 cfm
- + Sound: <40 NC
- + Equipment:
  - 1x Puraflo Reverse Flow (24 in. x 48 in.)
  - 1x Supply Diffuser

### Details

Open offices are densely populated areas with minimal fresh supply air, and lots of recycled air. HEPA filtration and an increased air change rate can help reduce the concentration of airborne pathogens<sup>1</sup> and other contaminants in crowded office spaces.

The number of Puraflo units required in an office is dependent on the number of air changes desired and the volume of the space. One reverse flow Puraflo unit operating at 400 cfm supplies enough airflow for an additional 2 ACH for every 1,200 ft<sup>2</sup> of office space (with 10 ft. ceilings).

The Puraflo and the corresponding supply diffuser should be positioned for maximum removal of airborne pathogens<sup>1</sup> and other contaminants in the space, and to avoid filtered air discharging directly into the Puraflo. Selection of the discharge diffuser should promote room air mixing and thermal comfort.

## DENTAL OPERATORY

### Room Specs

- + Room Size: 125 ft<sup>2</sup>
- + Ceiling Height: 9 ft.
- + Room Volume: 1125 ft<sup>3</sup>
- + Additional Air Changes: 8
- + Flow Rate: 150 cfm
- + Sound: <35NC
- + Equipment:
  - 1x Puraflo Reverse Flow or Dual-Outlet Reverse Flow (24 in. x 24 in.)
  - 1x Supply Diffuser

### Details

Rotary tools used during dental procedures may create aerosolized contaminants that can be detrimental to the wellbeing of dentists and hygienists. The amount of time required for removal of airborne pathogens and contaminants from a space varies based on the air change rate. As an example, increasing from 4 ACH, typical in many dental operatories, to 12 ACH reduces the time to remove 99.9% of airborne pathogens and other contaminants from 104 minutes to 35 minutes.

In dental offices the reverse flow Puraflo should be located near the patients feet so that



contaminated air is drawn away from the dental practitioner, and filtered air should be supplied from behind the patients head to wash the work space with clean air.

Optional use of a dual-outlet reverse flow Puraflo allows a portion of the airflow to be exhausted while the remainder is recirculated, simultaneously creating a negative pressure environment and increasing the air change rate to flush airborne pathogens<sup>1</sup> and other contaminants from the space.

For more information on dental applications, visit [www.pricecriticalenvironments.com/products/dental-operatories](http://www.pricecriticalenvironments.com/products/dental-operatories).



## PERSONAL CARE HOMES

### Room Specs

- + Room Size: 200 ft<sup>2</sup>
- + Ceiling Height: 9 ft.
- + Room Volume: 1,800 ft<sup>3</sup>
- + Additional Air Changes: 6
- + Flow Rate: 180 cfm
- + Sound: <30 NC
- + Equipment:
  - 1x Puraflo Reverse Flow (24 in. x 48 in.)
  - 1x Supply Diffuser

### Details

Reducing the concentration of airborne contaminants is of the utmost importance in personal care homes and other spaces with at-risk occupants. Increasing the air change rate in these spaces can help reduce the concentration of airborne pathogens<sup>1</sup> and other contaminants and therefore the probability of exposure to them.

One puraflo unit processing 180 cfm will provide an additional 6 ACH in a 200 ft<sup>2</sup> patient room (with 9 ft. ceilings).

In these applications the reverse flow Puraflo unit should be located near the door, with the recirculation diffuser located over the patient bed. This configuration provides clean airflow to the patient and encourages the movement of less-clean air toward the exit.



## PATIENT ISOLATION ROOMS

### Room Specs

- + Room Size: 150 ft<sup>2</sup>
- + Ceiling Height: 9 ft.
- + Room Volume: 1,350 ft<sup>3</sup>
- + Additional Air Changes: 8
- + Flow Rate: 180 cfm
- + Sound: <30 NC
- + Equipment:
  - 1x Puraflo Dual-Outlet Reverse Flow (24 in. x 48 in.)
  - 1x Supply Diffuser

### Details

Negative pressure isolation rooms are used for patients with easily communicable airborne disease. When there is a shortage of isolation rooms, existing hospital patient rooms can be converted to negative pressure isolation rooms by creating 0.01 in. w.g. negative pressure and by increasing from 4 to 12 ACH, in accordance with ASHRAE 170 requirements.

The dual-outlet reverse flow Puraflo allows a portion of the airflow to be exhausted while the remainder is recirculated, simultaneously creating a negative pressure environment and increasing the air change rate.



In these applications the Puraflo should be located directly over the patient's head so that contaminated air is drawn directly out of the room, and filtered air should be supplied toward the door so that airflow is encouraged to move from clean to less-clean areas of the room.

For more information on patient isolation rooms, that allow the user to easily change between normal operation of a patient room and isolation mode, visit [www.pricecriticalenvironments.com/products/retrofit-isolation-room](http://www.pricecriticalenvironments.com/products/retrofit-isolation-room).



## WAITING & RECEPTION AREAS

### Room Specs

- + Room Size: 300 ft<sup>2</sup>
- + Ceiling Height: 10 ft.
- + Room Volume: 3,000 ft<sup>3</sup>
- + Additional Air Changes: 4
- + Flow Rate: 200 cfm
- + Sound: <30 NC
- + Equipment:
  - 1x Puraflo Reverse Flow (24 in. x 48 in.)
  - 1x Supply Diffuser

### Details

Waiting and reception areas are typically densely populated and can see a lot of foot-traffic from many different people each and every day. Puraflo can be used in waiting and reception areas to increase the air change rate and remove airborne pathogens<sup>1</sup> and other contaminants from the space.

Waiting and reception areas vary in size based on the application, whether it be in a medical center, office building, or multi-family housing complex. As an example, a single reverse flow Puraflo unit operating at 200 cfm can provide an additional 4 ACH for a 300 ft<sup>2</sup> waiting area with 9 ft. ceilings.

The Puraflo and the corresponding supply diffuser should be positioned for maximum removal of airborne pathogens<sup>1</sup> and contaminants in the space, and to avoid filtered air discharging directly into the Puraflo. Selection of the discharge diffuser should promote room air mixing and thermal comfort.

## EASY MAINTENANCE

- + Quickly and easily replace both the MERV 8<sup>3</sup> and HEPA filter from the room-side.
- + Filter replacement schedule varies based on application, environmental conditions, and user preference. Generally:
  - MERV 8 pre-filters should be replaced every 6 months
  - HEPA filters should be replaced every 2 years
- + Integrated knife edge and HEPA filter gel track allow for tool-free installation and replacement.
- + MERV8 pre-filter captures large particulate, extending the life of the HEPA filter.

## ENERGY EFFICIENT

- + Puraflo provides increased air recirculation with lower energy consumption than a building-wide system.
- + Recirculation through individual Puraflo units allows for room-level control and energy expenditure, reducing overall energy consumption, and allowing for smaller building-wide systems

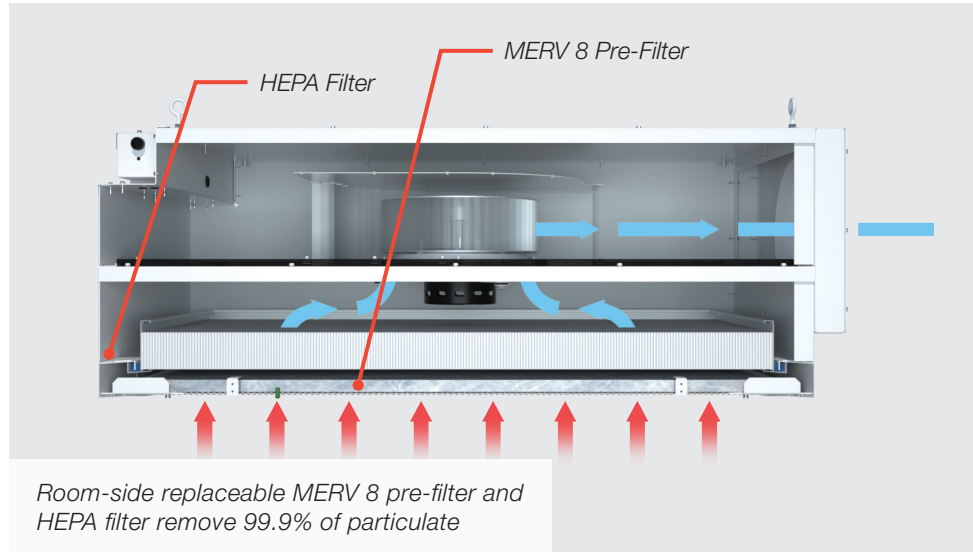

<sup>3</sup>MERV 8 pre-filter is not room-side replaceable on unit with supply construction.

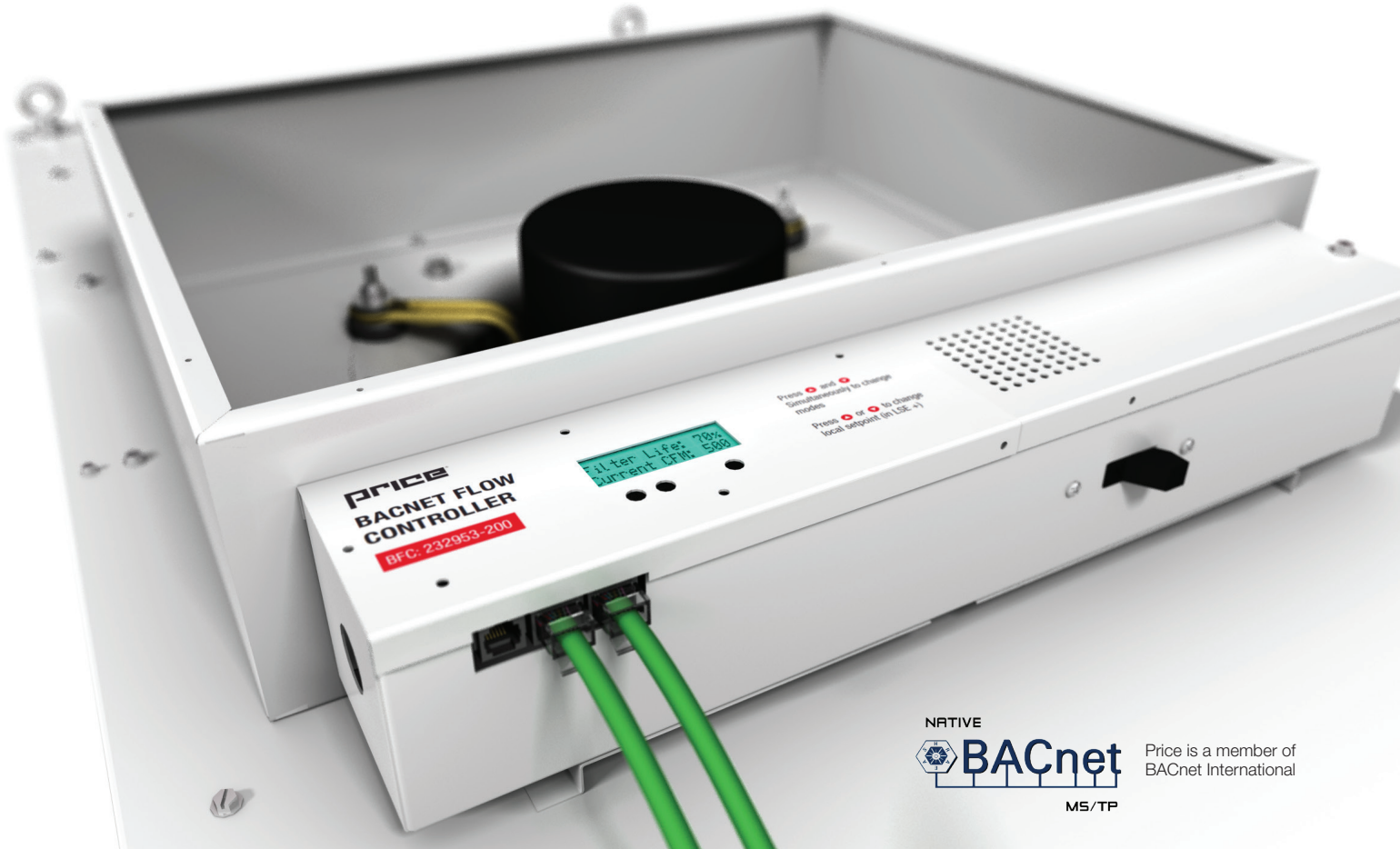

Price is a member of BACnet International

## BACNET FLOW CONTROLLER

Featuring tactile buttons and an LCD screen that displays important variables like CFM, the BACnet Flow Controller (BFC) is easy to setup and control locally or via BACnet.

## CONSTANT AIRFLOW

A constant flow motor program on the pre-programmed EC motor adjusts the motor to maintain the airflow rate as the filter loads over time - meaning the Puraflo will continue to provide the intended airflow (cfm) throughout the life of the filter.

## Key Features

- + Native BACnet MS/TP
- + Backlit LCD display
- + Several network points for control, monitoring or trending:
  - CFM output
  - Motor RPM and status
  - Motor hours
  - Filter status and pressure drop
  - Filter hours

## UV LIGHT

The UV light provides 360-degree of high UV-C intensity light and is integrated into the interior of the Puraflo unit. Widely used in hospitals and institutional applications, UV-C light (254nm) can play a role in improved indoor air quality.

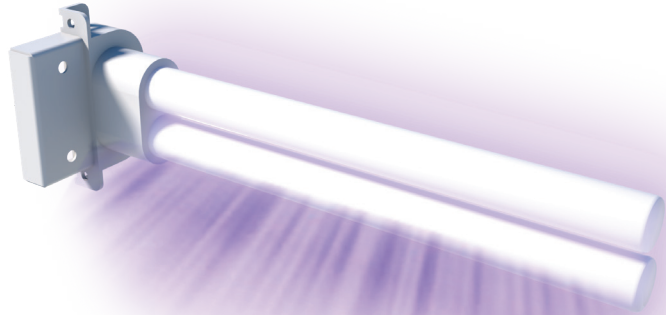

## BIPOLAR IONIZATION

The plasma air ionizer produces positive and negative oxygen ions to help neutralize airborne particulate. UL 2998 compliant bipolar ionizers are available as a standard option for the Puraflo.



## ROOM-SIDE FILTER AND MOTOR STATUS INDICATION

Optional face-mounted color LED alerts the user when the filter is loaded and due for replacement, or if the motor is not operating properly. A green LED indicates a pressure reading within operating range, an amber LED reading indicates a pressure reading above operating range (Loaded Filter) and a red LED indicates a pressure reading below operating range.

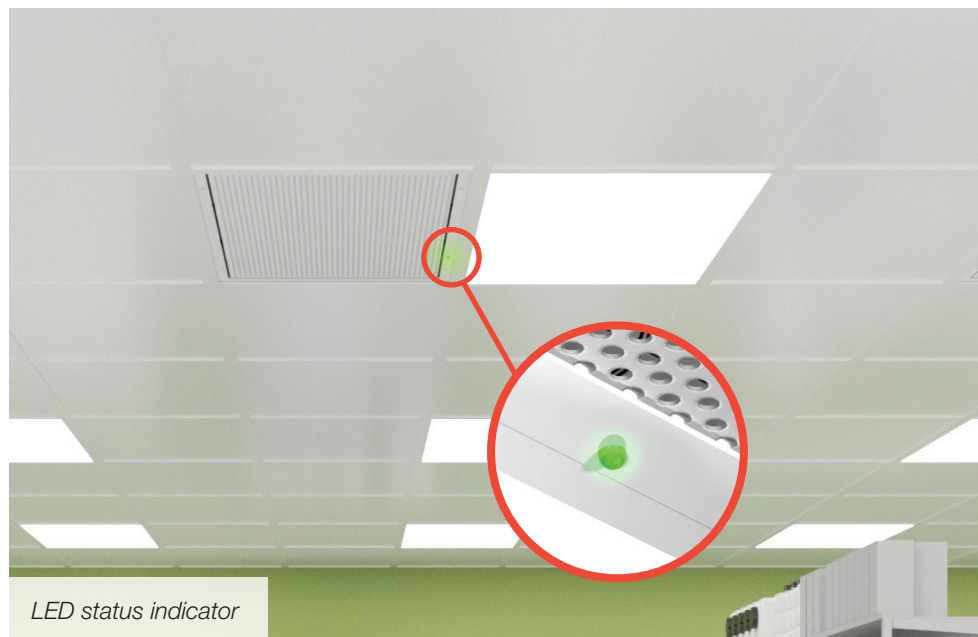

*LED status indicator*

## ROOM-SIDE ACCESSIBLE CONTROLS

- + The room-side accessible controls option features a rotating control box that allows access to the controls from both the top of the unit and from the room-side.
- + To access the control box from the room-side remove the diffuser face, HEPA filter, and gasketed controls cover located inside the plenum.
- + A disconnect switch is located on the face of the control box, and is easily accessible regardless of control box orientation.
- + Optional room-side accessible controls are available with all speed controllers.

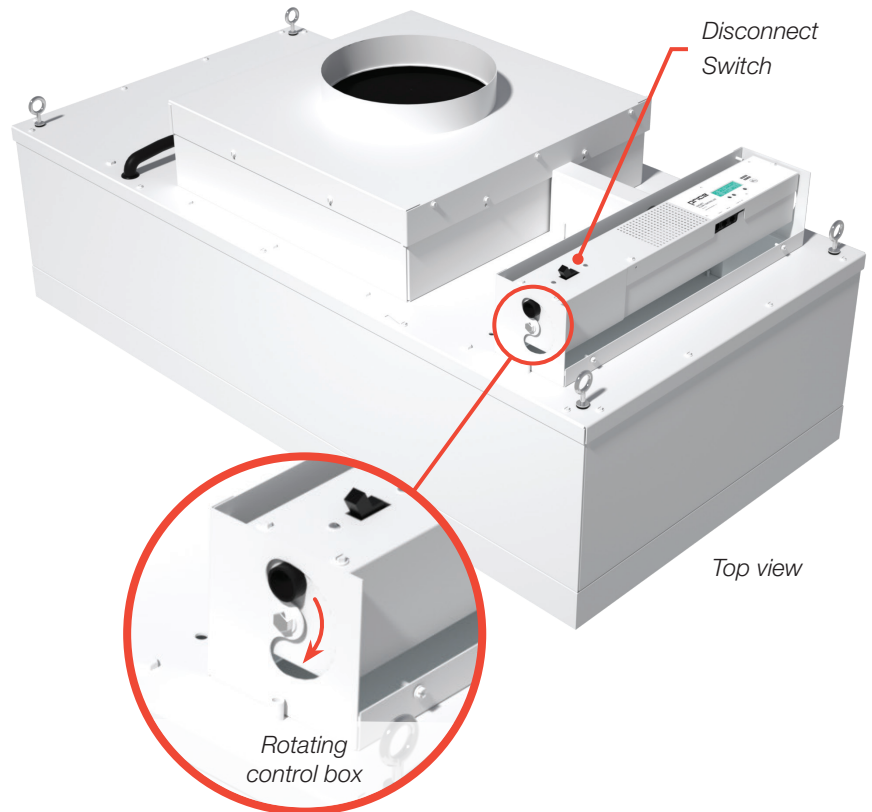

# DIMENSIONAL DATA

## Standard

Reverse Flow & Dual-Outlet  
Reverse Flow Configuration

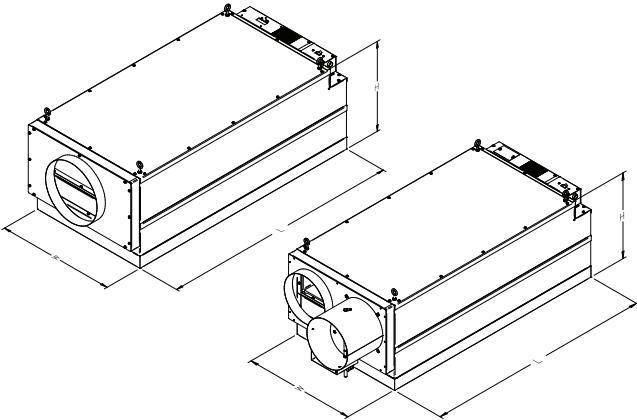

Nominal Unit Size	Actual Width (W)	Actual Length (L)	All Options	
			Height (H)	
24 in. x 24 in.	23.625 in.	23.625 in.	20.500 in.	
24 in. x 48 in.	23.625 in.	47.625 in.	18.000 in.	
24 in. x 48 in. (w /UVC)	23.625 in.	47.625 in.	20.900 in.	
610 mm x 610 mm	600 mm	600 mm	521 mm	
610 mm x 1220 mm	600 mm	1210 mm	457 mm	
610 mm x 1220 mm (w /UVC)	600 mm	1210 mm	531 mm	

Supply Flow Configuration

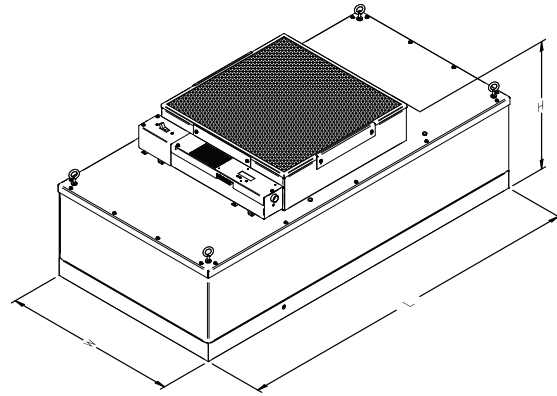

Nominal Unit Size	Actual Width (W)	Actual Length (L)	Non-Ducted	Ducted
			H (in.)	
24 in. x 24 in.	23.625 in.	23.625 in.	18.300 in.	18.800 in.
24 in. x 36 in.	23.625 in.	35.625 in.	18.300 in.	18.800 in.
24 in. x 48 in.	23.625 in.	47.625 in.	18.300 in.	18.800 in.
610 mm x 610 mm	600 mm	600 mm	465 mm	478 mm
610 mm x 915 mm	600 mm	905 mm	465 mm	478 mm
610 mm x 1220 mm	600 mm	1210 mm	465 mm	478 mm



## DIMENSIONAL DATA

### With Portable Cart

Reverse Flow & Dual-Outlet  
Reverse Flow Configuration

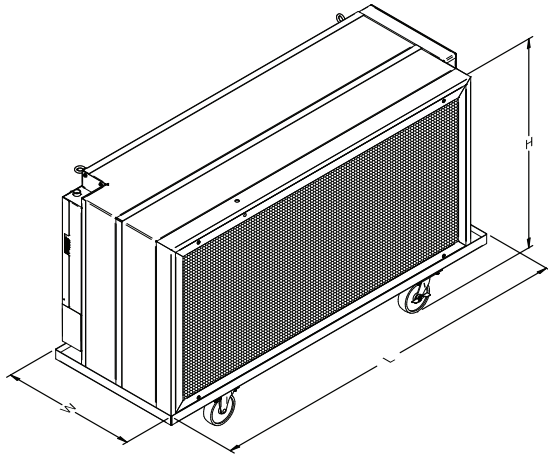

Supply Flow Configuration

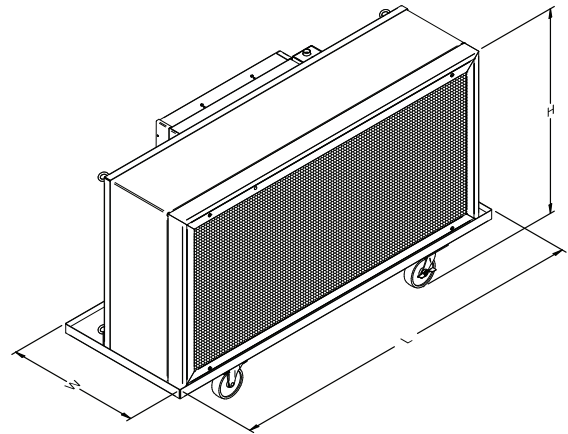

Nominal Unit Size	Unit Configuration	Actual Width (W)	Actual Length (L)	Height (H)
24 in. x 24 in.	Supply	18.475 in.	26.225 in.	28.750 in.
24 in. x 24 in.	Exhaust / Dual Outlet	20.975 in.	26.225 in.	28.750 in.
24 in. x 36 in.	Supply	18.475 in.	38.225 in.	28.750 in.
24 in. x 48 in.	Exhaust / Dual Outlet / Supply	18.475 in.	50.225 in.	28.750 in.
24 in. x 48 in. (w /UVC)	Exhaust / Dual Outlet	21.425 in.	50.225 in.	28.750 in.
610 mm x 610 mm	Supply	469 mm	666 mm	730 mm
610 mm x 610 mm	Exhaust / Dual Outlet	533 mm	666 mm	730 mm
610 mm x 915 mm	Supply	469 mm	971 mm	730 mm
610 mm x 1220 mm	Exhaust / Dual Outlet / Supply	469 mm	1275 mm	730 mm
610 mm x 1220 mm (w /UVC)	Exhaust / Dual Outlet	544 mm	1275 mm	730 mm

# PERFORMANCE DATA

## Supply Flow

Unit Size	Filter	Motor - Fan	Active Filter Area (sq. ft.)	Max CFM	Watts at Max CFM	CFM at 90 FPM	Watts at 90 FPM	Sound (dBA) at 90 FPM	Weight (lbs.)
24 in. x 48 in.	RSR	ECM - BC	5.3	750	140	480	60	53	76
		ECM - FC	5.3	750	210	480	80	52	74
		PSC - BC	5.3	750	215	480	160	54	76
		PSC - FC	5.3	750	395	480	295	52	74
24 in. x 36 in.	RSR	ECM - BC	3.8	540	110	345	50	53	64
		ECM - FC	3.8	540	150	345	65	50	62
		PSC - BC	3.8	540	175	345	150	51	64
		PSC - FC	3.8	540	320	345	230	49	62
24 in. x 24 in.	RSR	ECM - FC	2.3	300	125	210	65	48	53
		PSC - FC	2.3	300	180	210	125	52	53

**Performance Notes:**

- Units are tested in accordance with IEST RP-CC002.2, Recommended Practice for Unidirectional Flow Clean-Air Devices.
- Sound levels were measured with unit installed in a T-Bar ceiling, with gasket, in a standard room. Sound levels in dBA were measured at a distance of 30 inches from the filter face, with the unit set to produce 90 fpm average face velocity. (Note that data is for a clean filter only. If fan speed is increased to compensate for filter loading the noise level will increase.)
- For electrical circuit sizing, consult the "max amps" shown on the submittal for each product configuration and voltage.
- All data is based on a unit with a clean HEPA filter.
- 90 fpm values are based on active filter area.
- Heat Gain: BTUh = Watts x 3.413

## Reverse Flow

Unit Size	Filter	Motor - Fan	Active Filter Area (sq. ft.)	Max CFM	Watts at Max CFM	CFM at 90 FPM	Watts at 90 FPM	Sound (dBA) at 90 FPM	Weight (lbs.)
24 in. x 48 in.	RSR	ECM - FC	5.3	750	185	480	75	54	74
		PSC - FC	5.3	750	430	480	315	58	74
24 in. x 24 in.		ECM - FC	2.3	300	120	210	65	50	58
		PSC - FC	2.3	300	185	210	130	52	58

**Performance Notes:**

- Units are tested in accordance with IEST RP-CC002.2, Recommended Practice for Unidirectional Flow Clean-Air Devices.
- Sound levels were measured with unit installed in a T-Bar ceiling, with gasket, in a standard room. Sound levels in dBA were measured at a distance of 30 inches from the filter face, with the unit set to produce 90 fpm average face velocity. (Note that data is for a clean filter only. If fan speed is increased to compensate for filter loading the noise level will increase.)
- For electrical circuit sizing, consult the "max amps" shown on the submittal for each product configuration and voltage.
- All data is based on a unit with a clean HEPA filter.
- 90 fpm values are based on active filter area.
- Heat Gain: BTUh = Watts x 3.413

## Reverse Flow - UVC Option

Unit Size	Filter	Motor - Fan	Active Filter Area (sq. ft.)	Max CFM	Watts at Max CFM	CFM at 60 FPM	Watts at 60 FPM	Sound (dBA) at 60 FPM	Weight (lbs.)
24 in. x 48 in. (w/ UVC)	RSR	ECM - FC	5.3	580	350	320	95	55	80
		PSC - FC	5.3	580	430	320	160	57	80

**Performance Notes:**

- Units are tested in accordance with IEST RP-CC002.2, Recommended Practice for Unidirectional Flow Clean-Air Devices.
- Sound levels were measured with unit installed in a T-Bar ceiling, with gasket, in a standard room. Sound levels in dBA were measured at a distance of 30 inches from the filter face, with the unit set to produce 60 fpm average face velocity. (Note that data is for a clean filter only. If fan speed is increased to compensate for filter loading the noise level will increase.)
- For electrical circuit sizing, consult the "max amps" shown on the submittal for each product configuration and voltage.
- All data is based on a unit with a clean HEPA filter.
- 60 fpm values are based on active filter area.
- Heat Gain: BTUh = Watts x 3.413

## PERFORMANCE DATA - METRIC

### Supply

Unit Size (mm)	Filter	Motor - Fan	Active Filter Area (m <sup>2</sup> )	Max L/s	Watts at Max L/s	L/s at 0.46 m/s	Watts at 0.46 m/s	Sound (dBA) at 0.46 m/s	Weight (kg)
600 x 1200	RSR	ECM - BC	0.49	354	140	227	60	53	34
		ECM - FC	0.49	354	210	227	80	52	34
		PSC - BC	0.49	354	215	227	160	54	34
		PSC - FC	0.49	354	395	227	295	52	34
600 x 900	RSR	ECM - BC	0.35	255	110	163	50	53	29
		ECM - FC	0.35	255	150	163	65	50	28
		PSC - BC	0.35	255	175	163	150	51	29
		PSC - FC	0.35	255	320	163	230	49	28
600 x 600	RSR	ECM - FC	0.21	142	125	99	65	48	24
		PSC - FC	0.21	142	180	99	125	52	24

**Performance Notes:**

- Units are tested in accordance with IEST RP-CC002.2, Recommended Practice for Unidirectional Flow Clean-Air Devices.
- Sound levels were measured with unit installed in a T-Bar ceiling, with gasket, in a standard room. Sound levels in dBA were measured at a distance of 760 mm from the filter face, with the unit set to produce 0.46 m/s average face velocity. (Note that data is for a clean filter only. If fan speed is increased to compensate for filter loading the noise level will increase.)
- For electrical circuit sizing, consult the "max amps" shown on the submittal for each product configuration and voltage.
- All data is based on a unit with a clean filter.
- 0.46 m/s values are based on active filter area.
- Heat Gain: BTUh = Watts x 3.413

### Reverse Flow

Unit Size (mm)	Filter	Motor - Fan	Active Filter Area (m <sup>2</sup> )	Max L/s	Watts at Max L/s	L/s at 0.46 m/s	Watts at 0.46 m/s	Sound (dBA) at 0.46 m/s	Weight (kg)
600 X 1200	RSR	ECM - BC	0.5	354	185	227	75	54	26
		ECM - FC	0.5	354	430	227	315	58	26
600 X 600		PSC - BC	0.2	142	120	99	65	50	34
		PSC - FC	0.2	142	185	99	130	52	34

**Performance Notes:**

- Units are tested in accordance with IEST RP-CC002.2, Recommended Practice for Unidirectional Flow Clean-Air Devices.
- Sound levels were measured with unit installed in a T-Bar ceiling, with gasket, in a standard room. Sound levels in dBA were measured at a distance of 760 mm from the filter face, with the unit set to produce 0.46 m/s average face velocity. (Note that data is for a clean filter only. If fan speed is increased to compensate for filter loading the noise level will increase.)
- For electrical circuit sizing, consult the "max amps" shown on the submittal for each product configuration and voltage.
- All data is based on a unit with a clean filter.
- 0.46 m/s values are based on active filter area.
- Heat Gain: BTUh = Watts x 3.413

### Reverse Flow - UVC Option

Unit Size (mm)	Filter	Motor - Fan	Active Filter Area (m <sup>2</sup> )	Max L/s	Watts at Max L/s	L/s at 0.30 m/s	Watts at 0.30 m/s	Sound (dBA) at 0.30 m/s	Weight (kg)
600 x 1200 (w/ UVC)	RSR	ECM - FC	0.5	274	350	151	95	55	36
		PSC - FC	0.5	274	430	151	160	57	36

**Performance Notes:**

- Units are tested in accordance with IEST RP-CC002.2, Recommended Practice for Unidirectional Flow Clean-Air Devices.
- Sound levels were measured with unit installed in a T-Bar ceiling, with gasket, in a standard room. Sound levels in dBA were measured at a distance of 760 mm from the filter face, with the unit set to produce 0.30 m/s average face velocity. (Note that data is for a clean filter only. If fan speed is increased to compensate for filter loading the noise level will increase.)
- For electrical circuit sizing, consult the "max amps" shown on the submittal for each product configuration and voltage.
- All data is based on a unit with a clean filter.
- 0.30 m/s values are based on active filter area.
- Heat gain: BTUh = Watts x 3.413



Product Improvement is a continuing endeavour at Price. Therefore, specifications are subject to change without notice. Consult your Price Sales Representative for current specifications or more detailed information. Not all products may be available in all geographic areas. All goods described in this document are warranted as described in the Limited Warranty shown at [priceindustries.com](http://priceindustries.com). The complete Price product catalog can be viewed online at [priceindustries.com](http://priceindustries.com).