



DAMPERS

Dampers - Sub Section Contents

Relief Dampers	315 - 321H
Fire & Smoke Dampers	323 - 329H
Fire & Leakage Rated Dampers	330 - 348H
Volume Control Dampers	299 - 314H



HCD – Airfoil Control Damper



VOLUME CONTROL DAMPERS

HBD - 155 Balancing Control Damper.	311 - 313H
HCD - 75 Airfoil Control Damper.	308 - 311H
HCD - 150 Airfoil Control Damper.	300 - 306 & 311H
HCD - 225 Heavy Duty Airfoil Control Damper.	307 & 311H
Ordering Key and Specification.	314H

- Extruded Aluminium, or Galvanised Steel construction.
 - Full range of compatible hardware.
 - Airfoil blade (extruded aluminium).
 - Self inflating blade edge seal.
 - Flexible aluminium jamb seal.
 - Two piece bearings.
-

HCD – Airfoil Control Damper

Model: HCD-150

The Holyoake HCD-150 is a precisely made volume and pressure control device with extremely low leakage when closed. It offers great structural strength and very low resistance when open.

- Frame:** 6063 T5 extruded aluminium with mitred corners, mechanically locked with heavy aluminium gussets.
- Blades:** 6063 T5 three cavity full airfoil extrusion for main blades on 146 mm centres and half airfoil part blade for intermediate heights.
- Linkage:** Concealed in frame, with stainless steel cranks and link pins and aluminium control bars.
- Axles:** Hexagonal stainless steel.
- Bearings:** Two piece moulded glass reinforced nylon, pressed into frame, with the outer sleeve locked by locating ribs. (-8°C to 220 °C)
- Seals:** Blade edge and Jamb: Extruded EPDM, (0°C to 80°C). Side Seal: Flexible (convex) aluminium.
- Control Shaft:** **[Standard]:** Round Drive Shaft 120 mm, complete with Motor Mounting Plate - HCD32 Kit (HCD23 & 28). **[Optional]:**
[1] Hex Extension Shaft 23, 44, 93, or 300 mm, complete with Motor Mounting Plate - HCD 25, 26, 22, or 27, with a HCD 23.
[2] Hex Extension Shaft (93 mm) complete with Quadrant Arm and Plate – HCD31 Kit (HCD22/23/24).
- Blade Rotation:** **[Standard]:** Opposed
[Optional]: Parallel (specify if required).
- Finish:** Mill standard, anodized and powercoat options available.
- Minimum Size:** Channel Surround 200 mm Wide x 225 mm High.
 Flange Surround 150 mm Wide x 168 mm High. (Air Stream).
- Maximum Single Unit Size:** Channel Surround 1525 mm Wide x 1831 mm High.
 Flange Surround 1400 mm Wide x 1774 mm High. (Air Stream).

Special Construction Options

- Frame:** **[1]** Low Profile: Part blade and shallow frame members, top and bottom (12.5 mm), allow for heights between 150 and 225 mm (duct size).
[2] Flanged Surround: Extruded aluminium frame which is designed to match 35 mm proprietary duct flanging systems.
- Smoke Damper:** High Temperature HCD150-ET version available suitable for smoke applications see page 328H - 329H.

For other features contact your local Holyoake branch.

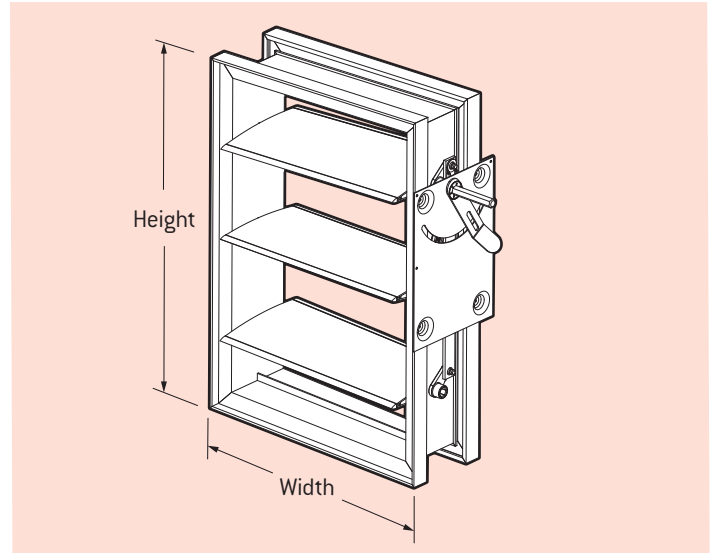

Installation

Dampers must be installed square and free from racking. Where mounted in large accessible plenum chambers, actuators can be located within, anchored to floor or ceiling, driving through either a blade bracket and swivel, or on multi section units, through a control arm on the jack shaft. Where the actuator is to be located externally, specify either Round Drive Shaft 120 mm, or for multi section dampers, extended jack shaft.

For manual control, use Hex Extension Shafts, Quadrant Arm and Plate. For multi section manual dampers, these are best fitted with individual Hex Extension Shafts, Quadrant Arm and Plates, per section.

Single Section Dampers

Blade Rotation

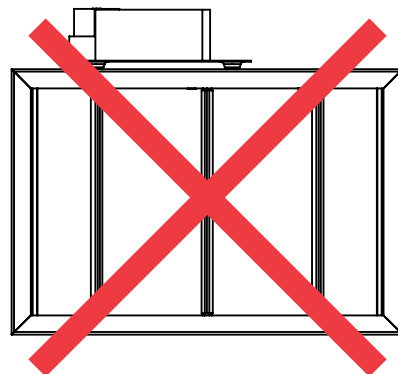
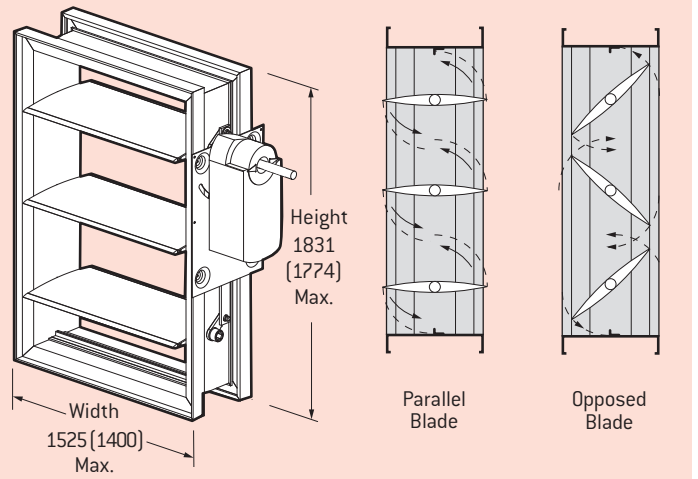

Motorised HCD-150 dampers must not be installed with the axles vertical.

Due to a policy of continuous development and improvement the right is reserved to supply products which may differ slightly from those illustrated and described in this publication.

Model: HCD-150

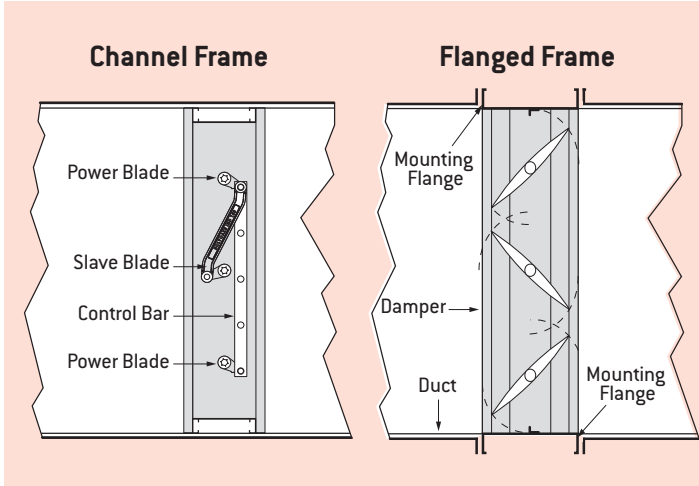

Duct Mounting

As most dampers are duct mounted, the HCD-150 is designed for quick, easy mounting by sliding into a section of duct.

Dampers with channel surrounds are fabricated approximately 7 mm less than given duct dimensions, unless specified otherwise.

Procedures

Standard Channel Surround:

- (1) Identify the axle to be fitted with either Round Drive Shaft for Motorisation, or Hex Extension Shaft with Quadrant Arm and Plate for Manual operation. This **must** be a “power blade” axle, i.e. every second shaft on opposed blade units, or every blade on parallel blade units.
- (2) Mark the side of the duct where this shaft will appear and cut a 25 mm hole with a chassis punch, or similar.
- (3) Apply a 3 mm thick sponge seal gasket to both “hat-section” flanges and slide the damper into position.
- (4) Use sheet metal screws to secure the damper. Do not over-tighten, to avoid “dimpling” the duct surface.
- (5) Fit on Round Drive Shaft and Motor Mounting Plate, or Hex Extension Shaft, with either Quadrant Arm and Plate, or Motor Mounting Plate, as applicable.
- (6) For high pressure units fit a sponge seal around the drive shaft.

Flanged Frame

Dampers are supplied with Round Drive Shaft, or Optional Hexagonal Extension Shaft and / or quadrant and mounting plate, factory fitted.

Install using suitable cleating method and gaskets applicable to the proprietary flanging system being used.

Guide Product Weights	
HCD 150 Airfoil Channel	Approximate Weight in Kg
300 x 200	2.39
500 x 200	3.16
HCD 150 Airfoil Flanged	Approximate Weight in Kg
800 x 400	6.24

Frame Styles

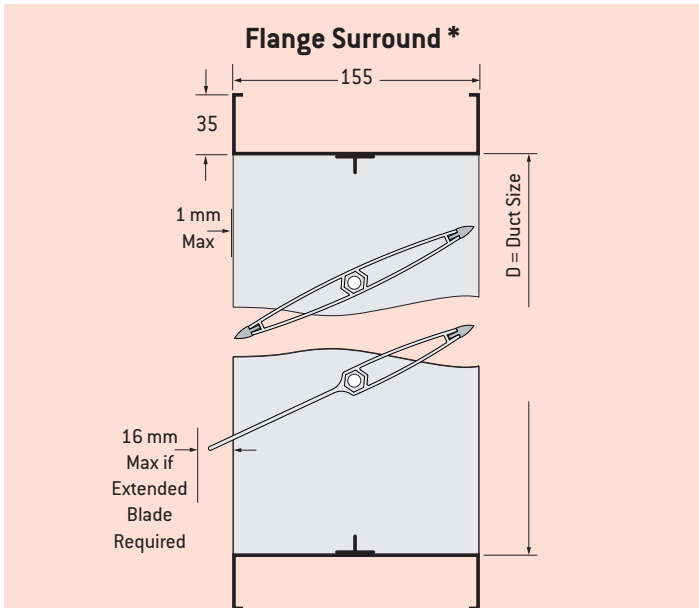
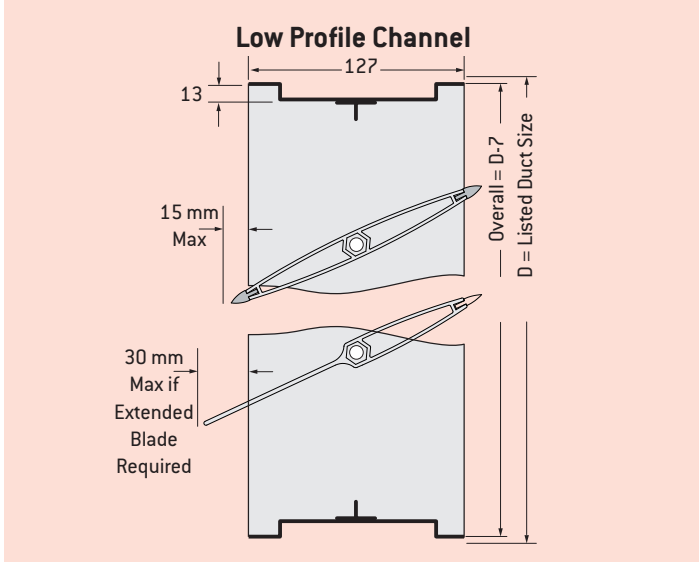
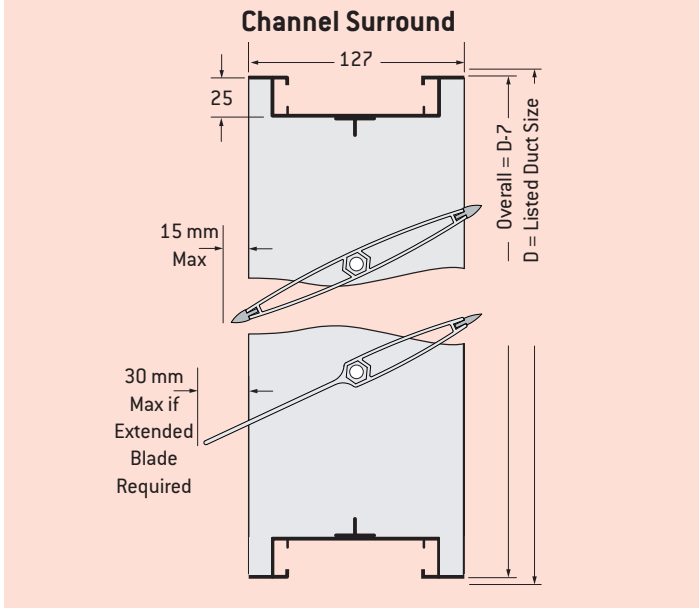

* This flange has been designed to couple with propriert duct flange systems

* This flange has been designed to couple with proprietary duct flange systems

Volume Control Dampers

HCD – Airfoil Control Damper

Model: **HCD-150**

Multi Section Assembly and Dimensional Information

Dampers larger than the maximum single section are manufactured as an assembly of single section dampers and may be coupled for operation in a variety of ways.

Dampers may be connected using female to hex couplings, or a 25 mm diameter jackshaft can be used as illustrated below.

Assemblies may be constructed from unequal sized dampers.

Larger Multi-Section Assemblies require an understanding of the dampers function and the quantity and type of motors to be used, to determine the most suitable coupling method. Often it is more economical and mechanically efficient, to fit actuators to individual sections.

Examples:

A 1800 Wide x 1500 High damper would be an ASSEMBLY consisting of two 900 Wide x 1500 High damper sections, less tolerance and mullions.

A 3150 Wide x 2500 High damper would be an ASSEMBLY consisting of six 1050 Wide x 1250 High damper sections, less tolerance and mullions.

If specific section sizes are required for installation reasons, please advise your local Holyoake branch when ordering.

NOTE: Minimum damper height for Jack Shafted Multi-Section damper assemblies is 4 blades high, (Approximately 584 mm, varies dependant on frame style).

For smaller heights use hex-to-hex couplings between sections.

Multi-Section damper assemblies are shipped completely factory assembled (subject to shipping size limitations and other considerations).

Multi Section Maximum Dimensions

Nominate whether Parallel, or Opposed Blade for each Section.

Channel Frame: All dimensions include 7mm clearance.

Flanged Frame: (in brackets) all dimensions are duct size.

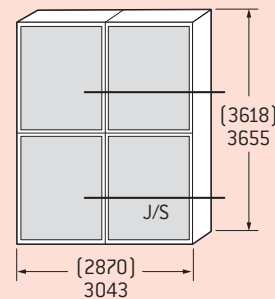
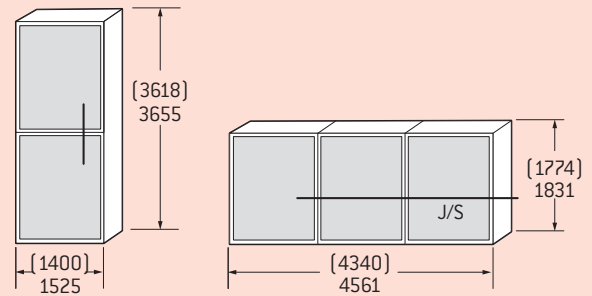

J/S Jack Shaft

Linking Multi Section Damper Assemblies

Option 1:
Female to hex
direct linkage
(flange frame shown)

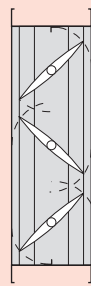

Opposed
Blade

Slide Together

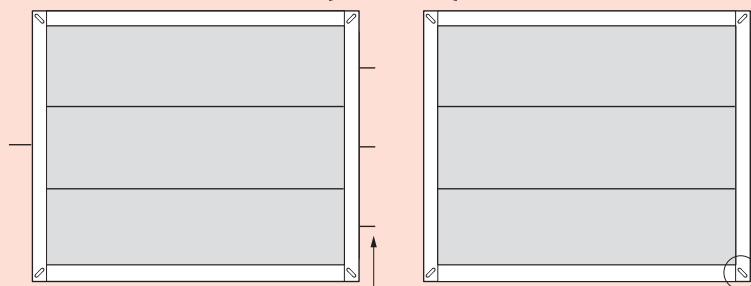

Link Couplers

Option 2:
Jackshafting
(channel frame shown)

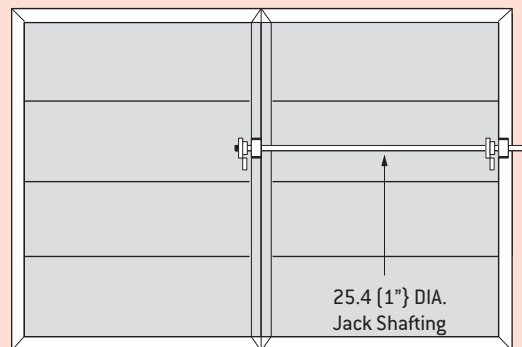
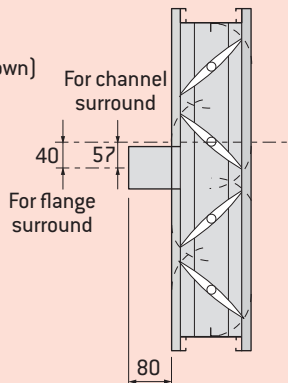

25.4 [1"] DIA.
Jack Shafting

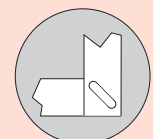

20x11mm
Corner Slot
(Prepunched)

Model: HCD-150

Bracing of Multi Section Damper Assemblies

The HCD-150 is self supporting only in its largest single section size. Multi-Section damper assemblies require bracing to support the weight of the assembly and to hold against the system pressure, (supply and fit by others). To support the damper horizontally, brace at least once for every 2.5m of damper width. Vertical assemblies and high system pressures will require more bracing.

Linking Multi Section Damper Assemblies

Option 1:

For smaller dampers use female to hex direct linkage coupling.

Option 2:

Larger dampers may require special jack shafting arrangements. Discuss with your local Holyoake branch.

Face and Bypass Mixing Dampers

Face and Bypass Mixing Dampers are available in a variety of combinations.

These can be operated with the use of opposing motors, driving one section open whilst the other closes, which is the most positive operation.

Other methods available include Jack Shaft, or Hex to Hex couplings.

Please contact your local Holyoake Branch to discuss prior to ordering.

Face & Bypass Mixing Dampers

HCD - 150 - FBR

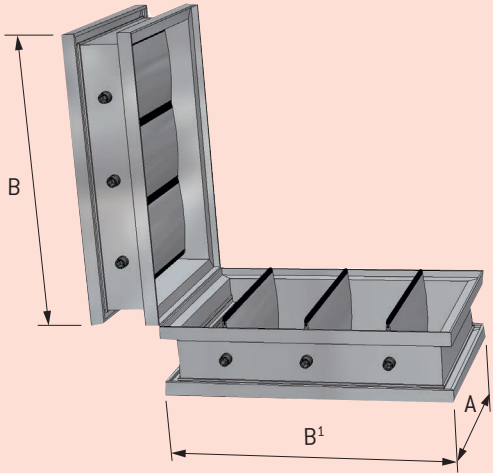

HCD - 150 - FBV

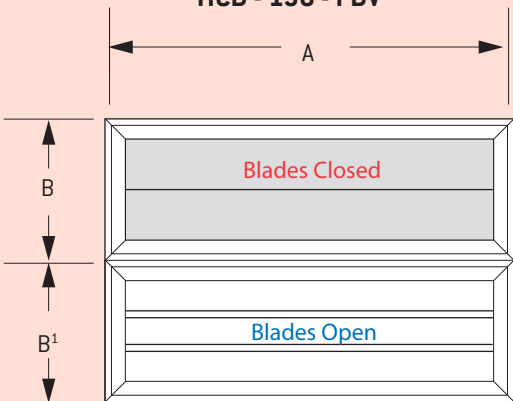

HCD - 150 - FBH

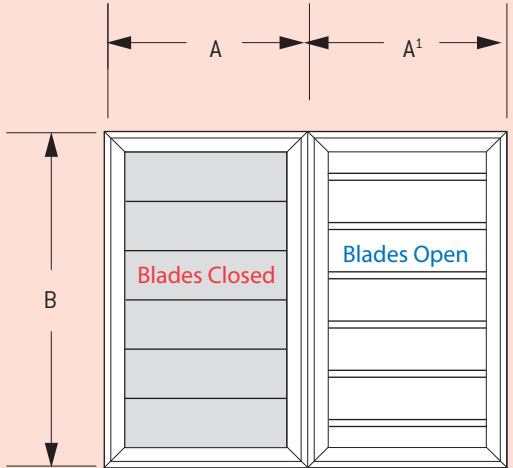

HCD – Performance Data

Model: HCD-150 Pressure Drop Data - Channel Surround

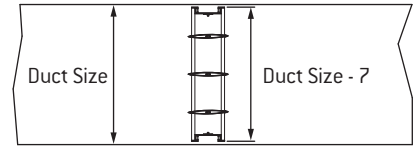

Area Factor Table

Duct Height (mm)	No. of Blades	Duct Width (mm)																								
		300	350	400	450	500	550	600	650	700	750	800	850	900	950	1000	1050	1100	1150	1200	1250	1300	1350	1400	1450	1500
225	1	34.5	28.6	24.4	21.3	18.9	17.0	15.4	14.1	13.0	12.1	11.3	10.6	9.9	9.4	8.9	8.4	8.0	7.7	7.3	7.0	6.7	6.5	6.2	6.0	5.8
371	2	16.4	13.6	11.6	10.2	9.0	8.1	7.4	6.7	6.2	5.8	5.4	5.0	4.7	4.5	4.2	4.0	3.8	3.7	3.5	3.3	3.2	3.1	3.0	2.9	2.8
517	3	10.8	8.9	7.6	6.7	5.9	5.3	4.8	4.4	4.1	3.8	3.5	3.3	3.1	2.9	2.8	2.6	2.5	2.4	2.3	2.2	2.1	2.0	2.0	1.9	1.8
663	4	8.0	6.7	5.7	5.0	4.4	4.0	3.6	3.3	3.0	2.8	2.6	2.5	2.3	2.2	2.1	2.0	1.9	1.8	1.7	1.6	1.6	1.5	1.5	1.4	1.4
809	5	6.4	5.3	4.5	3.9	3.5	3.1	2.9	2.6	2.4	2.2	2.1	2.0	1.8	1.7	1.6	1.6	1.5	1.4	1.4	1.3	1.2	1.2	1.2	1.1	1.1
955	6	5.3	4.4	3.8	3.3	2.9	2.6	2.4	2.2	2.0	1.9	1.7	1.6	1.5	1.4	1.4	1.3	1.2	1.2	1.1	1.1	1.0	1.0	1.0	0.9	0.9
1101	7	4.5	3.8	3.2	2.8	2.5	2.2	2.0	1.9	1.7	1.6	1.5	1.4	1.3	1.2	1.2	1.1	1.1	1.0	1.0	0.9	0.9	0.9	0.8	0.8	0.8
1247	8	4.0	3.3	2.8	2.5	2.2	2.0	1.8	1.6	1.5	1.4	1.3	1.2	1.1	1.1	1.0	1.0	0.9	0.9	0.8	0.8	0.8	0.7	0.7	0.7	0.7
1393	9	3.5	2.9	2.5	2.2	1.9	1.7	1.6	1.4	1.3	1.2	1.2	1.1	1.0	1.0	0.9	0.9	0.8	0.8	0.7	0.7	0.7	0.7	0.6	0.6	0.6
1539	10	3.2	2.6	2.2	2.0	1.7	1.6	1.4	1.3	1.2	1.1	1.0	1.0	0.9	0.9	0.8	0.8	0.7	0.7	0.7	0.6	0.6	0.6	0.6	0.5	0.5
1685	11	2.9	2.4	2.0	1.8	1.6	1.4	1.3	1.2	1.1	1.0	0.9	0.9	0.8	0.8	0.7	0.7	0.7	0.6	0.6	0.6	0.6	0.5	0.5	0.5	0.5
1831	12	2.6	2.2	1.9	1.6	1.4	1.3	1.2	1.1	1.0	0.9	0.9	0.8	0.8	0.7	0.7	0.6	0.6	0.6	0.6	0.5	0.5	0.5	0.5	0.5	0.4

[All dimensions include 7 mm clearance total between outside of damper frame and inside of duct].

To determine the pressure drop through a fully open HCD-150 use the following procedure:

1. Find the Area Factor from the table above, enter Duct Width and Height.
2. Determine the Conversion Velocity (CV) by multiplying the Area Factor by the air flow in m³/s [CV = Area Factor x m³/s].
3. Enter the pressure drop chart below with the Area Factor and establish the intersection with the Conversion Velocity (CV) line just determined. Read the pressure drop (Pa) on the left hand side of the chart.

Example:

Find the pressure drop across a 350 mm wide x 517 mm high model HCD-150 with a channel surround (Duct Size), passing an airflow of 0.84 m³/s.

1. From the table using the interpolation, the Area Factor is 8.9.
2. CV = 0.84 x 8.9 = 7.5.
3. From the chart below, the pressure drop reads 10 Pa.

Note: Interpolations while not precise are adequate for most calculations.

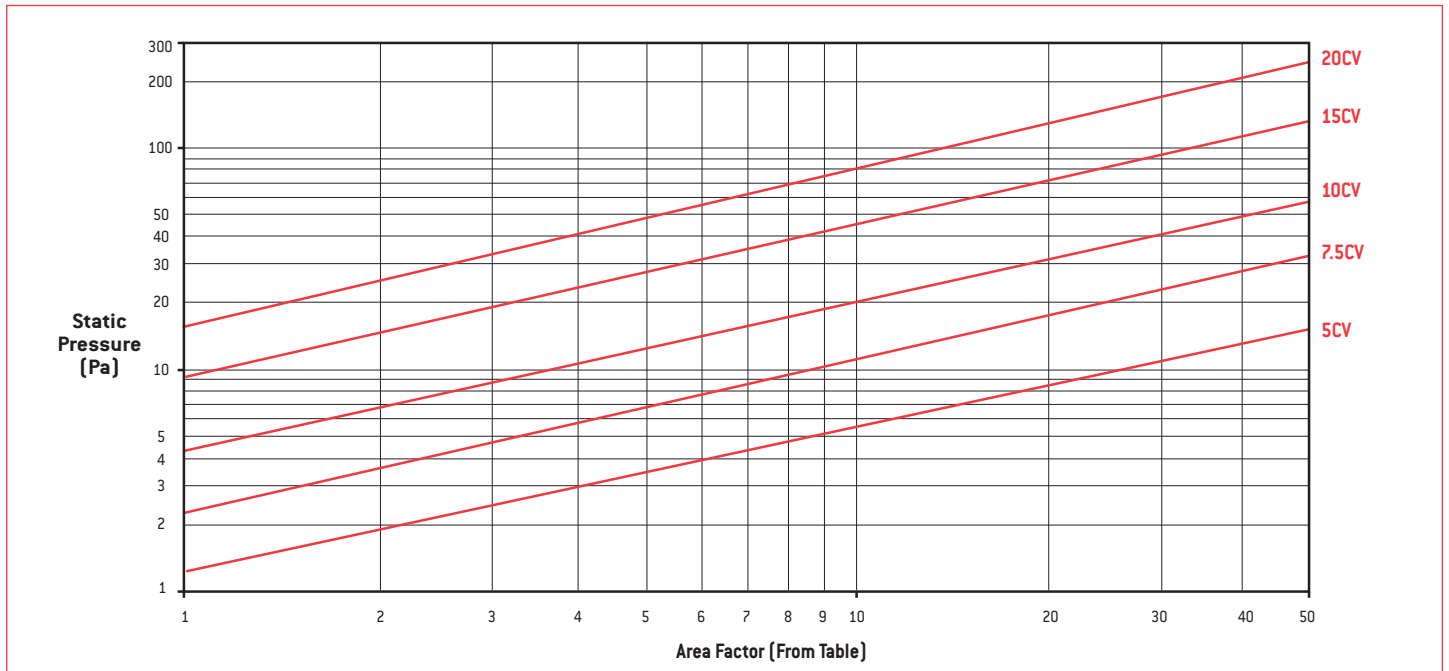

Notes

1. Static Pressure and Conversion Velocities are for air density of 1.2 kg/m³.
2. Pressure drop data is for dampers tested with ductwork on both the up and downstream sides. These values need to be suitably increased where dampers are mounted with ductwork on one side only, or when mounted onto plenum walls.
3. Data is for the specific sizes in the Area Factor table. For other sizes use the next size down and make a proportional adjustment based on the approximate increase in free area.
4. Use a factor of 1 on the Pressure Drop chart above, when the Area Factor is less than 1.

[Refer to SMACNA, or ASHRAE system design guides].

Model: HCD-150 Pressure Drop Data - Flange Surround

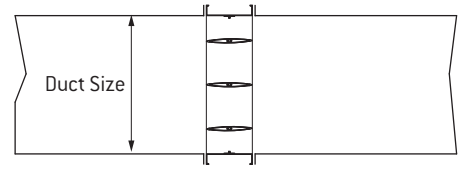

Area Factor Table																									
Duct Height (mm)	No. of Blades	Duct Width (mm)																							
		250	300	350	400	450	500	550	600	650	700	750	800	850	900	950	1000	1050	1100	1150	1200	1250	1300	1350	1400
168	1	33.5	28.0	24.0	21.0	18.6	16.8	15.2	14.0	12.9	12.0	11.2	10.5	9.9	9.3	8.8	8.4	8.0	7.6	7.3	7.0	6.7	6.5	6.2	6.0
314	2	16.0	13.3	11.4	10.0	8.9	8.0	7.3	6.7	6.1	5.7	5.3	5.0	4.7	4.4	4.2	4.0	3.8	3.6	3.5	3.3	3.2	3.1	3.0	2.9
460	3	10.5	8.7	7.5	6.5	5.8	5.2	4.8	4.4	4.0	3.7	3.5	3.3	3.1	2.9	2.8	2.6	2.5	2.4	2.3	2.2	2.1	2.0	1.9	1.9
606	4	7.8	6.5	5.6	4.9	4.3	3.9	3.5	3.2	3.0	2.8	2.6	2.4	2.3	2.2	2.1	1.9	1.9	1.8	1.7	1.6	1.6	1.5	1.4	1.4
752	5	6.2	5.2	4.4	3.9	3.4	3.1	2.8	2.6	2.4	2.2	2.1	1.9	1.8	1.7	1.6	1.6	1.5	1.4	1.3	1.3	1.2	1.2	1.1	1.1
898	6	5.2	4.3	3.7	3.2	2.9	2.6	2.3	2.1	2.0	1.8	1.7	1.6	1.5	1.4	1.4	1.3	1.2	1.2	1.1	1.1	1.0	1.0	1.0	0.9
1044	7	4.4	3.7	3.2	2.8	2.5	2.2	2.0	1.8	1.7	1.6	1.5	1.4	1.3	1.2	1.2	1.1	1.1	1.0	1.0	0.9	0.9	0.8	0.8	0.8
1190	8	3.9	3.2	2.8	2.4	2.1	1.9	1.8	1.6	1.5	1.4	1.3	1.2	1.1	1.1	1.0	1.0	0.9	0.9	0.8	0.8	0.8	0.7	0.7	0.7
1336	9	3.4	2.9	2.4	2.1	1.9	1.7	1.6	1.4	1.3	1.2	1.1	1.1	1.0	1.0	0.9	0.9	0.8	0.8	0.7	0.7	0.7	0.6	0.6	0.6
1482	10	3.1	2.6	2.2	1.9	1.7	1.5	1.4	1.3	1.2	1.1	1.0	1.0	0.9	0.9	0.8	0.8	0.7	0.7	0.7	0.6	0.6	0.6	0.6	0.5
1628	11	2.8	2.3	2.0	1.7	1.6	1.4	1.3	1.2	1.1	1.0	0.9	0.9	0.8	0.8	0.7	0.7	0.7	0.6	0.6	0.6	0.6	0.5	0.5	0.5
1774	12	2.6	2.1	1.8	1.6	1.4	1.3	1.2	1.1	1.0	0.9	0.9	0.8	0.8	0.7	0.7	0.6	0.6	0.6	0.6	0.5	0.5	0.5	0.5	0.5

[All dimensions assume the duct size is the airstream size of the damper].

To determine the pressure drop through a fully open HCD-150 use the following procedure:

1. Find the Area Factor from the table above, enter Duct Width and Height.
2. Determine the Conversion Velocity (CV) by multiplying the Area Factor by the air flow in m³/s (CV = Area Factor x m³/s).
3. Enter the pressure drop chart below with the Area Factor and establish the intersection with the Conversion Velocity (CV) line just determined.
Read the pressure drop (Pa) on the left hand side of the chart.

Note: Interpolations while not precise are adequate for most calculations.

Example:

Find the pressure drop across a 500 mm wide x 606 mm high model HCD-150 with a flange surround (Airstream Size), passing 2.8 m³/s.

1. From the table using the interpolation, the Area Factor is 3.9.
2. CV = 2.8 x 3.9 = 10.9.
3. From the chart below, the pressure drop reads 13 Pa.

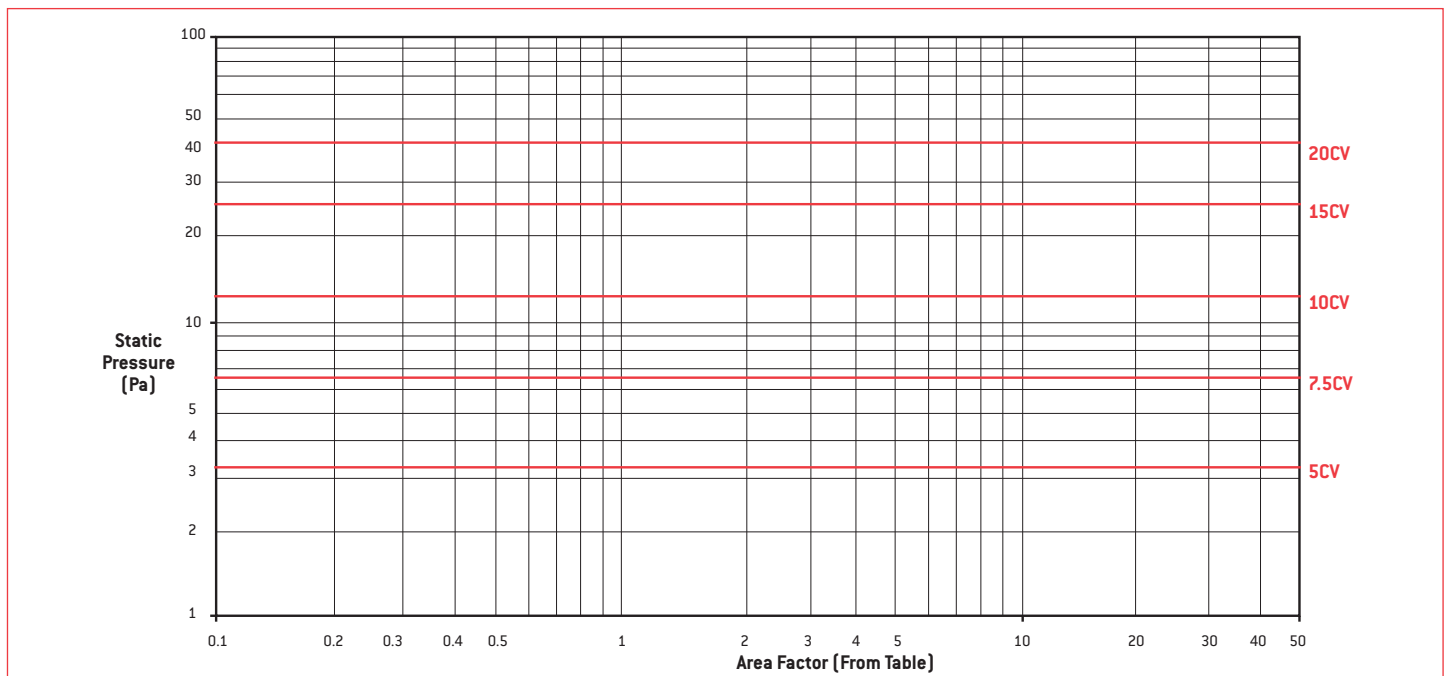

Notes

1. Static Pressure and Conversion Velocities are for air density of 1.2kg/m³.
2. Pressure drop data is for dampers tested with ductwork on both the up and downstream sides. These values need to be suitably increased where dampers are mounted with ductwork on one side only, or when mounted onto plenum walls.
3. Data is for the specific sizes in the Area Factor Table. For other sizes use the next size down and make a proportional adjustment based on the approximate increase in free area.

(Refer to SMACNA, or ASHRAE system design guides).

HCD – Performance Data

Model: HCD-150 Leakage Data

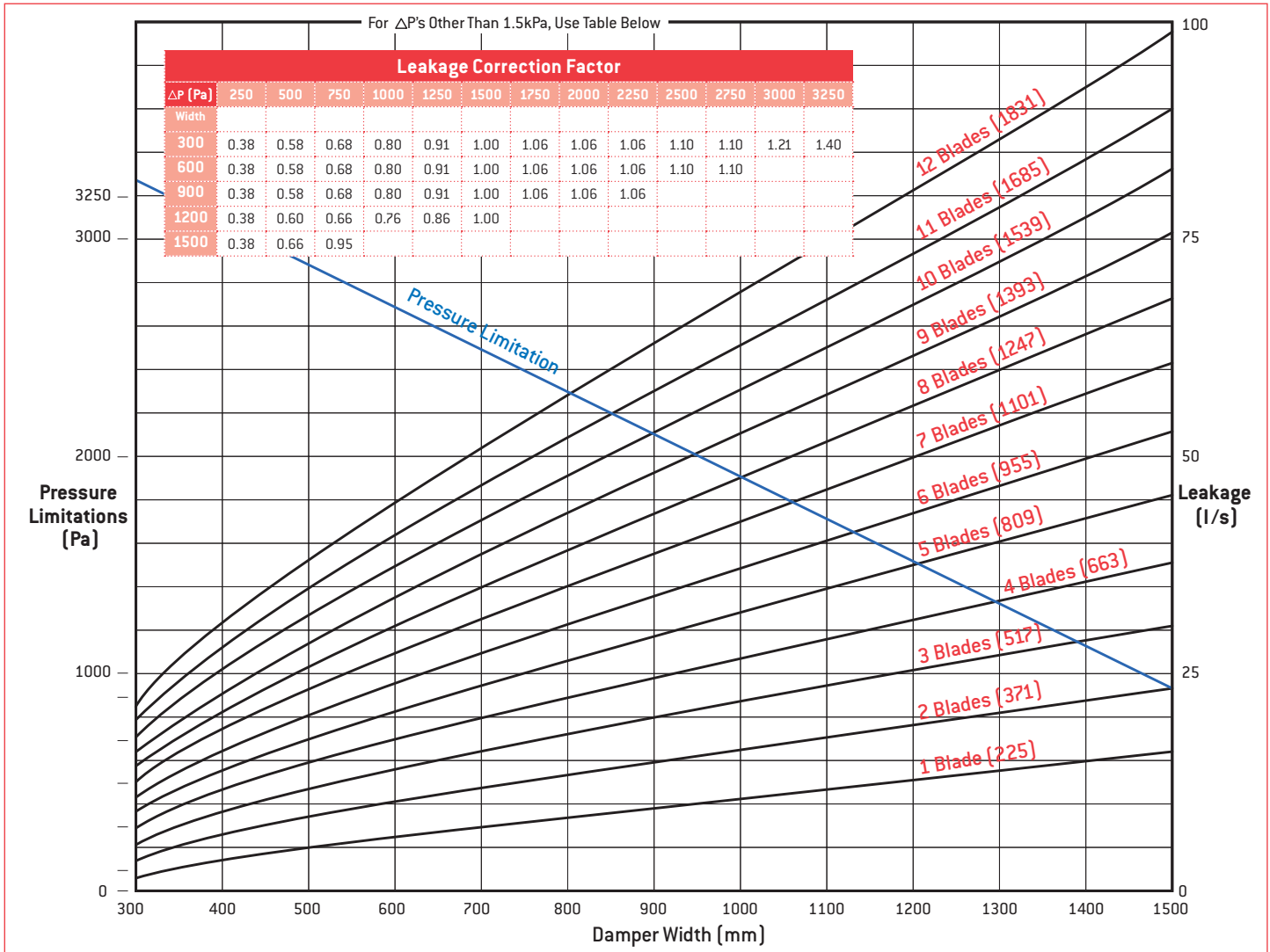

Leakage Through a Closed HCD-150

Example:

To determine the leakage through a 1200 mm wide x 1101 mm high (7 bladed) damper at 500 Pa ΔP.

- Enter the graph above at 1200 mm width and read the intersection at the 7 blade line. Read the right hand side of the chart at 50 l/s.
- Read the leakage correction factor for 1200 mm width and 500Pa from the table within the chart above = 0.60.
- Calculate the leakage as $50 \times 0.60 = 30$ l/s.

HCD-150 – Sound Rating

Damper Size	Damper Full Open		Damper 75% Open		Damper 50% Open		Damper 25% Open	
	m ³ /s	NC	m ³ /s	NC	m ³ /s	NC	m ³ /s	NC
300 x 300	0.943	17	0.708	11	0.472	11	0.236	*
	1.415	28	1.062	22	0.708	19	0.354	*
	1.887	35	1.415	29	0.943	24	0.472	*
450 x 450	1.062	17	0.797	10	0.531	21	0.266	*
	2.124	33	1.593	26	1.062	32	0.531	*
	3.185	43	2.389	37	1.593	40	0.797	15
600 x 600	1.887	11	1.415	10	0.943	26	0.472	*
	3.775	32	2.831	30	1.887	38	0.944	21
	5.663	43	4.247	42	2.831	46	1.415	31

NC = Noise Criteria in Decibels is based on 10 dB room attenuation.

* Less than 10 NC.

Note: Above are indicative examples of measured values.

Pressure Limitations on a Closed HCD-150

Example:

To establish pressure differential limitations for a damper with 1 metre long blades.

- Enter the graph above at 1000 mm damper width.
- Read the intersection with the 'Pressure Limitation' line at the left hand side of the chart as 1900 Pa.

Notes

- Leakage is frequently specified as a percentage of maximum design flow. Typically full flow velocity on the above example would be 5 m/s, which would require volumetric flow of $5 \times 1.2 \times 1.101 = 6606$ l/s. Leakage would in this case be $(30 \times 100) / 6606 = 0.45\%$.
- Above leakage figures are based on a closing torque of 1.3 Nm per m² of damper area, with a minimum of 2.4 Nm.
- Pressure limitations established by the above graph are intended to limit deflection on the longest blade (1500mm) to 8.3mm. Deflections for 1200mm or shorter blades, at higher pressure differentials, will be substantially less.

Heavy Duty Airfoil Control Damper – HCD

Model: HCD-225

The Holyoake HCD-225 is a heavy duty control damper which has been designed for applications that exceed the design parameters of the HCD-150 control damper.

Typically this is in areas of extremely high differential pressure, high turbulence, or velocity, or severe buffeting, which prevent the use of a standard control damper.

The HCD-225 is a specialised item and consultation with the factory is essential prior to ordering, to ensure that the best solution for each application is determined.

Please discuss with your local Holyoake branch.

Construction

- Frame:** 6065 T5 extruded aluminium, 6mm nominal thickness.
- Blades:** 6063 T5 full aerofoil extrusion 3mm nominal thickness. Positioned at 225 mm centres.
- Linkage:** 60 x 6 mm mild steel plate welded to 20 mm square blade axles. Movable joints assembled with brass bearings.
- Axles:** 20 mm square mild steel solid shaft, inserted into blades and bolted with M8 hardware.
- Bearings:** Heavy duty spherical ball bearings in greased and sealed races, mounted in the aluminium frame.
- Seals:** Anodized extruded aluminium side Seals.
- Controls:** To suit specific requirements.
- Operation:** Parallel blade rotation only.
- Finish:** Mill finish standard, anodized and powdercoat options available.
- Minimum Size:** 400 mm wide x 345 mm high overall flange.
- Maximum Size:** 1500 mm wide x 2360 mm high overall flange (Single Section).
- General:** Dampers are manufactured with Full blades only, (top and bottom weirs are extended to provide intermediate sizes).

HCD-225 Dampers must not be installed with the axles vertical.

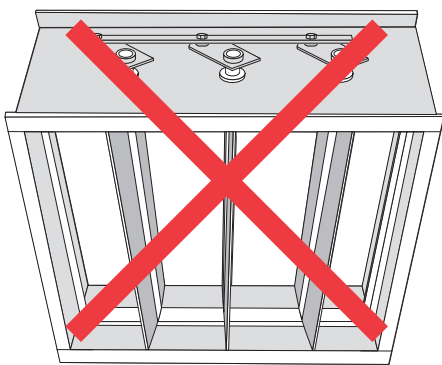

Due to a policy of continuous development and improvement the right is reserved to supply products which may differ slightly from those illustrated and described in this publication.

Heavy Duty Control Damper

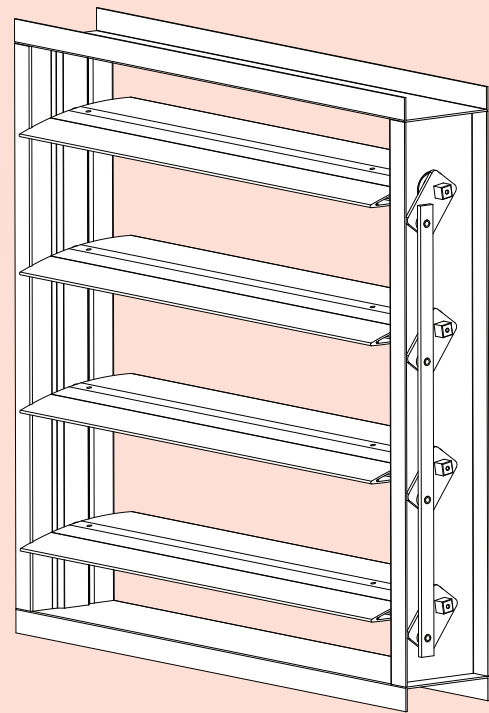

Dimensions

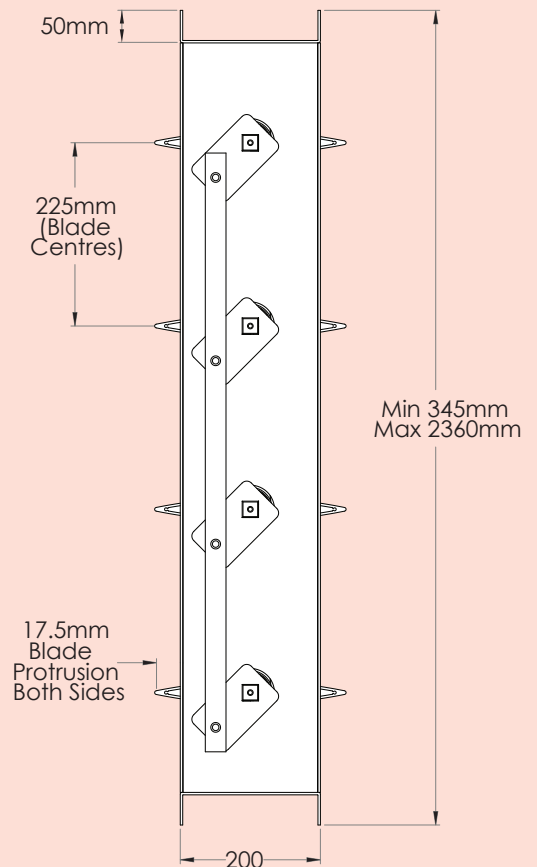

Guide Product Weights

HCD 225 Heavy Duty Airfoil	Approximate Weight in Kg
1200 x 900	28
1200 x 1400	41

HCD – Airfoil Control Damper

Model: HCD-75

The Holyoake HCD-75 is a precision made volume and pressure control device, with extremely low leakage when closed. It provides better control of an air stream in a size between an OBD3 and the HCD-150. Like the HCD-150, the HCD-75 offers low resistance when open.

Standard Construction

- Frame:** 6063 T5 extruded aluminium with square cut ends, mechanically joined with screws tapped into screw pipes.
- Blades:** 6063 T5 three cavity extrusion providing a full airfoil section.
- Linkage:** Concealed in frame, with stainless steel cranks and link pins and aluminium control bars.
- Axles:** Hexagonal stainless steel.
- Bearings:** Two piece moulded glass reinforced nylon, pressed into frame, with the outer sleeve locked with locating ribs (-8° to 220°C).
- Seals:** Blade edge & Jamb: Extruded EPDM, (0°C to 80°C). Side Seal: Flexible (convex) aluminium.
- Control Shaft:** **[Standard]:** Round Drive Shaft 120 mm, complete with Motor Mounting Plate - HCD32 Kit (HCD23 & 28).
[Optional]:
[1] Hex Extension Shaft 23, 44, 93, or 300 mm, complete with Motor Mounting Plate - HCD 25, 26, 22, or 27, with a HCD 23.
[2] Hex Extension Shaft (93 mm) complete with Quadrant Arm and Plate – HCD31 Kit (HCD22/23/24).
- Blade Rotation:** **[Standard]:** Opposed
[Optional]: Parallel (specify if required).
- Finish:** Mill standard, anodized and powercoat options available.
- Minimum Size:** 150 mm wide and 95 mm high (Air Stream).
- Maximum Size:** 950 mm wide and 898 mm high (Air Stream).
- General:** The specified size is the duct airstream size. The actual overall size is the airstream size plus 50 mm.

Special Construction Options

Smoke Damper: High Temperature HCD75-ET version available suitable for smoke applications see page 328H - 329H.

For other features please contact your local Holyoake Branch.

Installation

Dampers must be installed square and free from racking. Typically the method of driving the damper depends on its application. Where the actuator is to be located externally, specify Round Drive Shaft 120 mm. For manual control, use Hex Extension Shafts, Quadrant Arm and Plate.

Motorised HCD-75 dampers must not be installed with the axles vertical.

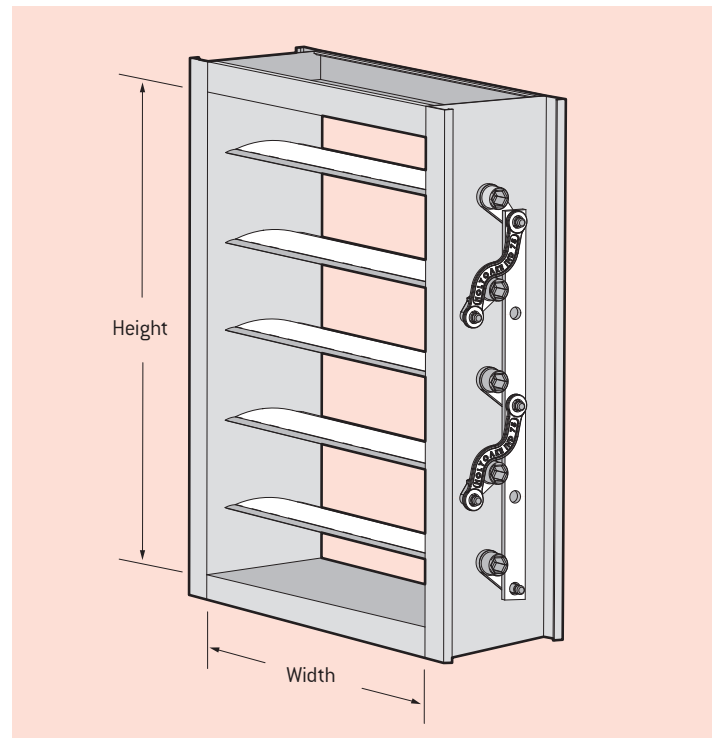
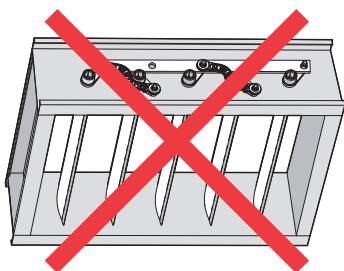

Duct Mounting

The HCD-75 has been specifically designed to be installed using 25 mm proprietary duct flanging systems.

This means that the damper can be installed in exactly the same way as a piece of flanged duct.

This way of mounting the HCD-75 provides an easy installation method and maintains the maximum amount of free area, which is especially important as the HCD-75 control damper is more likely to be used in smaller sized ducts. The HCD-75 can also be mounted inside a duct in much the same way as an HCD-150 Standard Channel damper.

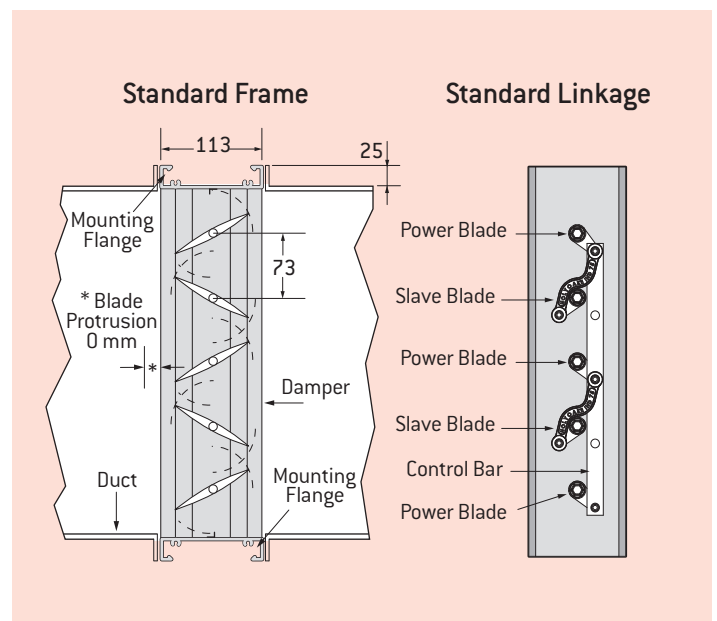

The location to be fitted with either a locking quadrant, or motorised drive shaft **must** be a "power blade" axle on the linkage side of the damper, i.e. every second shaft on opposed blade dampers, or every blade on parallel blade dampers.

Model: HCD-75 Pressure Drop Data - Flange Surround

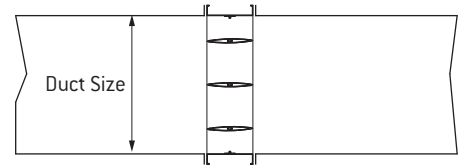

		Area Factor Table																
Duct Height (mm)	No. of Blades	Duct Width (mm)																
		150	200	250	300	350	400	450	500	550	600	650	700	750	800	850	900	950
95	1	140.5	105.4	84.3	70.2	60.2	52.7	46.8	42.1	38.3	35.1	32.4	30.1	28.1	26.3	24.8	23.4	22.2
168	2	62.4	46.8	37.4	31.2	26.7	23.4	20.8	18.7	17.0	15.6	14.4	13.4	12.5	11.7	11.0	10.4	9.8
241	3	40.1	30.1	24.0	20.0	17.2	15.0	13.4	12.0	10.9	10.0	9.2	8.6	8.0	7.5	7.1	6.7	6.3
314	4	29.5	22.1	17.7	14.8	12.7	11.1	9.8	8.9	8.1	7.4	6.8	6.3	5.9	5.5	5.2	4.9	4.7
387	5	23.4	17.5	14.0	11.7	10.0	8.8	7.8	7.0	6.4	5.8	5.4	5.0	4.7	4.4	4.1	3.9	3.7
460	6	19.3	14.5	11.6	9.7	8.3	7.3	6.4	5.8	5.3	4.8	4.5	4.1	3.9	3.6	3.4	3.2	3.1
533	7	16.5	12.4	9.9	8.2	7.1	6.2	5.5	4.9	4.5	4.1	3.8	3.5	3.3	3.1	2.9	2.7	2.6
606	8	14.4	10.8	8.6	7.2	6.2	5.4	4.8	4.3	3.9	3.6	3.3	3.1	2.9	2.7	2.5	2.4	2.3
679	9	12.7	9.6	7.6	6.4	5.5	4.8	4.2	3.8	3.5	3.2	2.9	2.7	2.5	2.4	2.2	2.1	2.0
752	10	11.4	8.6	6.9	5.7	4.9	4.3	3.8	3.4	3.1	2.9	2.6	2.5	2.3	2.1	2.0	1.9	1.8
825	11	10.4	7.8	6.2	5.2	4.5	3.9	3.5	3.1	2.8	2.6	2.4	2.2	2.1	1.9	1.8	1.7	1.6
898	12	9.5	7.1	5.7	4.8	4.1	3.6	3.2	2.9	2.6	2.4	2.2	2.0	1.9	1.8	1.7	1.6	1.5

[All dimensions assume the duct size is the airstream size of the damper].

To determine the pressure drop through a fully open HCD-75 use the following procedure:

1. Find the Area Factor from the table above, enter Duct Width and Height.
2. Determine the Conversion Velocity (CV) by multiplying the Area Factor by the air flow in m³/s [CV = Area Factor x m³/s].
3. Enter the pressure drop chart below with the Area Factor and establish the intersection with the Conversion Velocity (CV) line just determined.

Read the pressure drop (Pa) on the left hand side of the chart.

Note: Interpolations while not precise are adequate for most calculations.

Example:

Find the pressure drop across a 600 mm wide x 606 mm high model HCD-75 with a flange surround (Airstream Size), passing 2.8 m³/s.

1. From the table using the interpolation, the Area Factor is 3.6.
2. CV = 2.8 x 3.6 = 10.
3. From the chart below, the pressure drop reads 13 Pa.

Guide Product Weights	
HCD 75 Airfoil Flanged	Approximate Weight in Kg
300 x 200	2.39
500 x 200	3.16

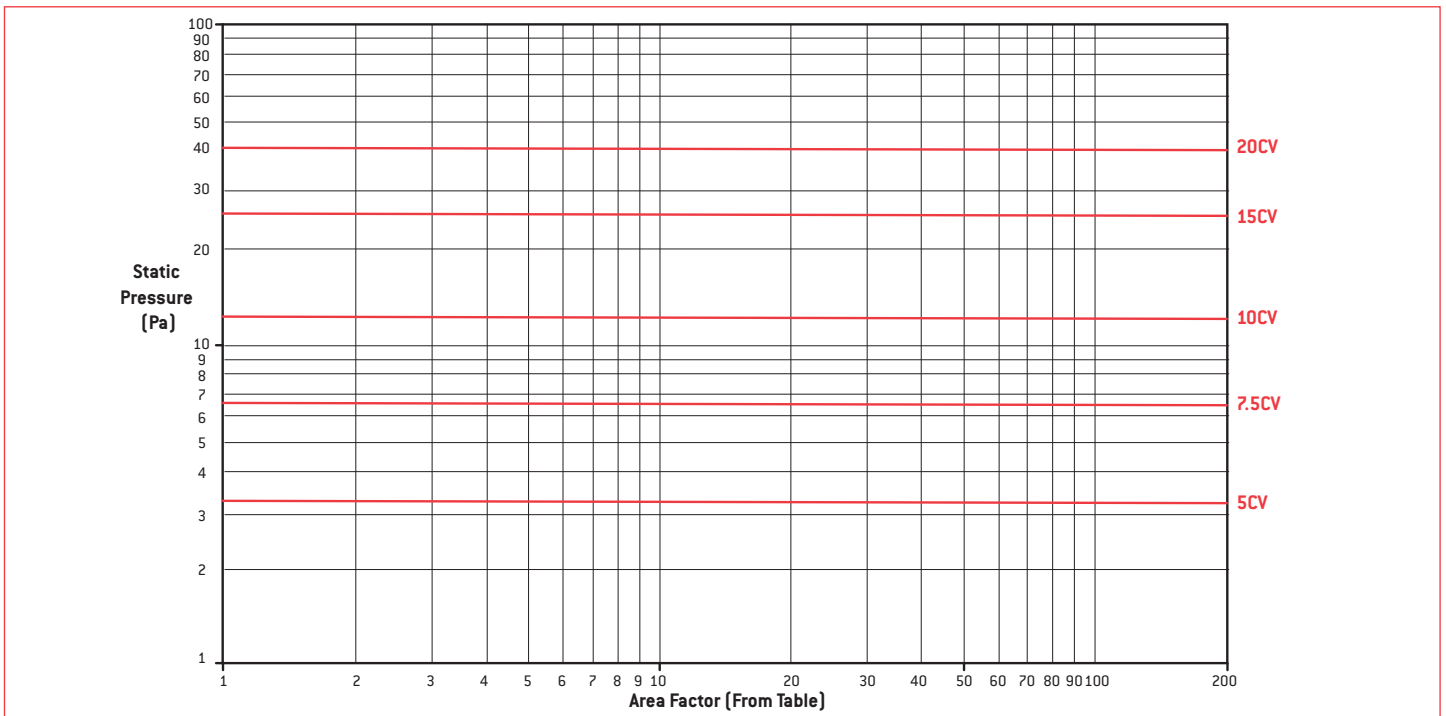

Notes

1. Static Pressure and Conversion Velocities are for air density of 1.2kg/m³.
2. Pressure drop data is for dampers tested with ductwork on both the up and downstream sides. These values need to be suitably increased where dampers are mounted with ductwork on one side only, or when mounted onto plenum walls. (Refer to SMACNA, or ASHRAE system design guides).
3. Data is for the specific sizes in the Area Factor Table. For other sizes use the next size down and make a proportional adjustment based on the approximate increase in free area.

Model: HCD-75 Leakage Data

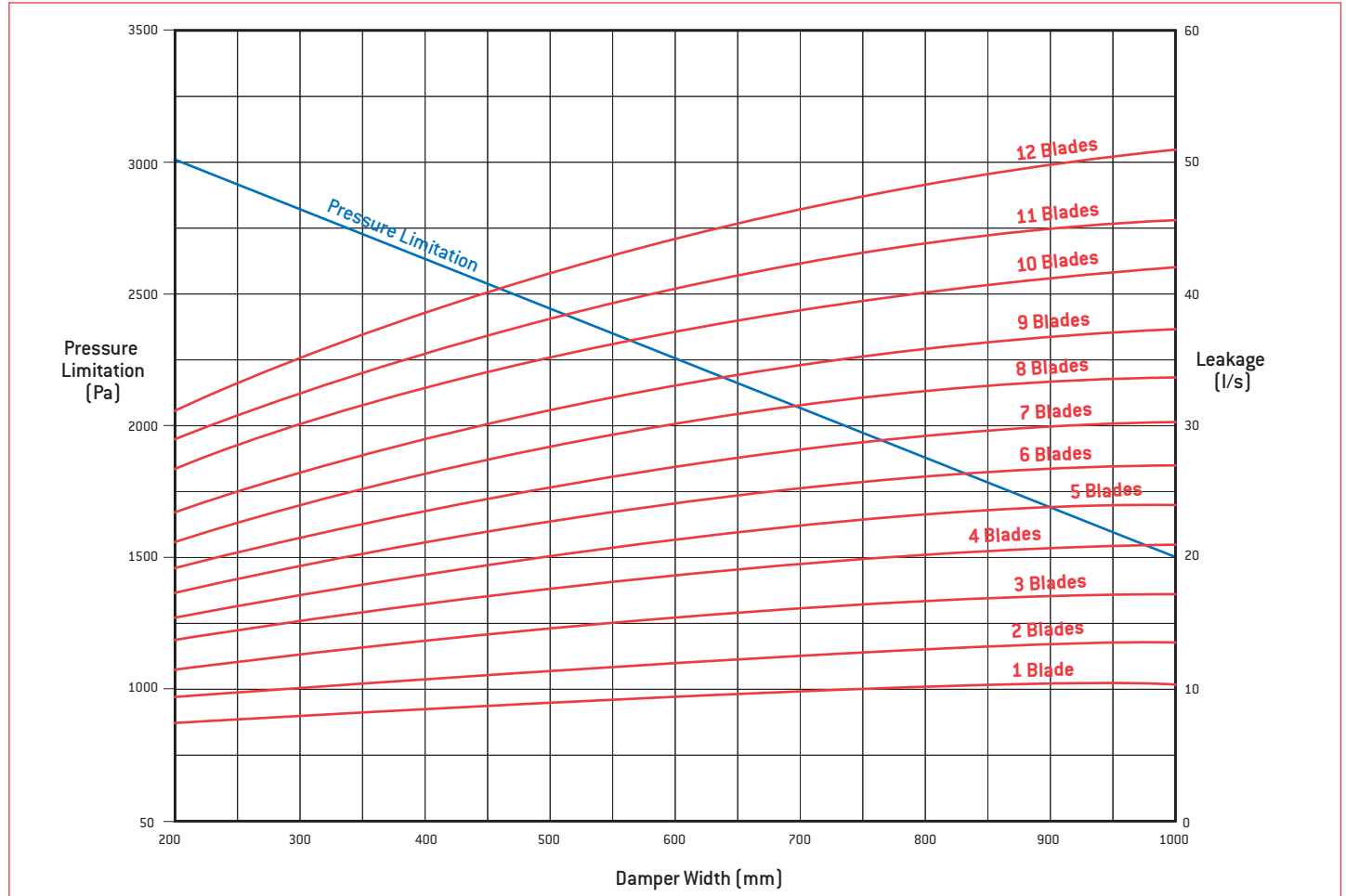

Leakage through a Closed HCD-75

Example:

To determine the leakage through a 600 mm wide x 444 mm high (5 bladed) damper at 1500 Pa ΔP .

- Enter the graph above at 600 mm width and read the intersection at the 5 blade line. Read the right hand side of the chart at 21 l/s.
- Read the leakage correction factor for 600 mm width and 1500 Pa from the table below = 1.
- Calculate leakage as $21 \times 1 = 21$ l/s.

Pressure Limitations on a Closed HCD-75

Example:

To establish pressure differential limitations for a damper with 600 mm long blades.

- Enter the graph above at 600 mm damper width.
- Read the intersection with the 'Pressure Limitation' line at the left hand side of the chart as 2250 Pa.

For ΔP 's other than 1.5k Pa, Use table below.

LEAKAGE CORRECTION FACTOR												
ΔP (Pa)	250	500	750	1000	1250	1500	1750	2000	2250	2500	2750	3000
Width												
200	0.38	0.58	0.68	0.80	0.91	1.00	1.06	1.06	1.06	1.10	1.21	1.40
400	0.38	0.58	0.68	0.80	0.91	1.00	1.06	1.06	1.06	1.10		
600	0.38	0.58	0.68	0.80	0.91	1.00	1.06	1.06	1.06			
800	0.38	0.60	0.66	0.76	0.91	1.00	1.06					
1000	0.38	0.60	0.66	0.76	0.86	1.00						

Notes

- Leakage is frequently specified as a percentage of maximum design flow. Typically full flow velocity on the above example would be 5 m/s, which would require volumetric flow of $5 \times 0.6 \times 0.444 = 1332$ l/s. Leakage would in this case be $(21 \times 100) / 1332 = 1.58\%$.
- Above leakage figures are based on a minimum closing torque of 2.4 Nm.
- Pressure limitations established by the above graph are intended to limit deflection on the longest blade (1000 mm) to 7 mm. Deflections for 800 mm or shorter blades, at higher pressure differentials, will be substantially less.

Standard Drive & Coupling Components

Standard Hardware

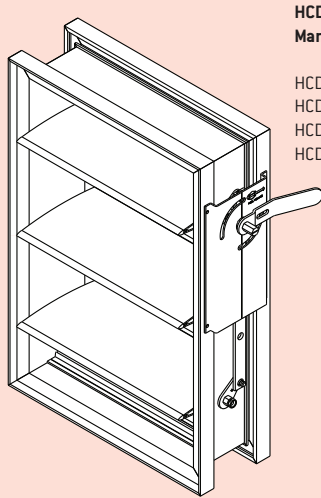

HCD-31 KIT
Manual Quadrant

HCD-02
HCD-22.36
HCD24
HCD16

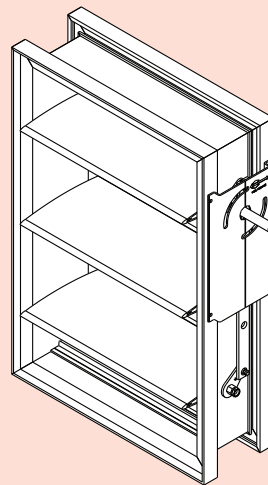

HCD-32 KIT
Actuator

HCD-02
HCD-01.120
HCD-16

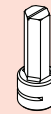

HCD-22
Hex Drive Shaft
36mm or 90mm



HCD-01
Actuator Drive Shaft
60mm or 120mm

HCD-18
Slotted Crank Arm
12.5 mm Hole

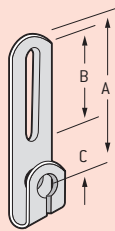

HCD-19
As Above with
25 mm Hole

	A	B	C
HCD 18	92	67	15
HCD 19	142	79	52

HCD-09
Standard Jackshaft
Bearing (25.4 mm)

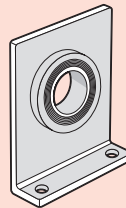

HCD-07
Standard Jackshaft
Link Arm
25.4 mm Dia

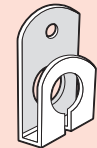

HCD-17
Control Arm
& Swivel

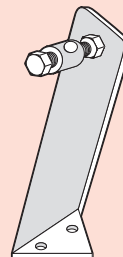

HCD-15
Coupler Bracket Assembly

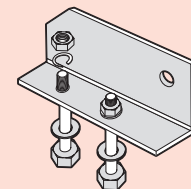

HCD-20
Swivel



Component	Description	Component	Description
HCD31	Manual Quadrant Kit includes HCD02, HCD22.36, HCD24, HCD16	HCD15	Coupler Bracket Assembly
HCD32	Actuator Kit includes HCD02, HCD01, HCD16	HCD16	Two Piece Hex Axle Bearing [-8 - 220°C]
HCD01	Round Actuator Drive Shaft 60, 120mm	HCD1602	Two Piece Round Axle Bearing [-8 - 220°C]
HCD02	Aluminium bracket for manual or actuated operation of damper	HCD17	Control Arm and Swivel
HCD04	Hex Coupler 29, 47mm	HCD18	Slotted Crank Arm 12.7mm Hole
HCD05	Tie Rod Arm	HCD19	Slotted Crank Arm 25.4mm Hole
HCD06	Tie Rod Bearing	HCD20	Swivel
HCD07	Standard Jackshaft Link Arm 25.4mm Dia	HCD21	8mm Stainless Steel Rod
HCD08	Mini Jackshaft Link Arm 12.7mm Dia	HCD22	Hex Manual Quadrant Drive Shaft 36,90mm
HCD09	Standard Jackshaft Bearing 25.4mm	HCD24	Manual Crank Arm
HCD10	Mini Jackshaft Bearing 12.7mm	HCD24EXT	PRD Counter Weight Arm
HCD11	25.4 x 1.8mm Stainless Steel Tubing	HCD34	One Piece Round Linkage Bearing [-8 - 220°C]
HCD11A	12.7 x 1.2mm Stainless Steel Tubing	HCD35	Manual Quadrant for 1/2" Shaft
HCD12	Stainless Steel Split Pin	HCDSSWIRECLIP	HCD Stainless Steel Wire Clip
HCD13E	Stainless Steel Axle & Crank	HCD150LINKARM	Aluminium Link Arm to suit HCD150
HCD13F	Stainless Steel Axle & Crank (Opposite Hand)	HCD75LINKARM	Aluminium Link Arm to suit HCD75
HCD13G	Stainless Steel Plain Hex Axle		

HBD – Balancing Damper

Model: HBD-155

The Holyoake HBD-155 is a control damper designed for airflow balancing. It can be manually positioned, or motorised options are available.

The HBD-155 frame has been designed to align with 35 mm proprietary duct flange systems for ease of installation.

Standard Construction

- Frame:** 6063 T5 extruded aluminium with square cut ends, mechanically joined with screws tapped into screw pipes.
- Blades:** 6063 T5 extruded aluminium with a full cavity hex to prevent the rotation of the blades on the shaft.
- Linkage:** Concealed in frame, with stainless steel cranks with link pins and aluminium control bars.
- Axles:** Hexagonal.
- Bearings:** Two piece moulded glass reinforced nylon, pressed into frame, with the outer sleeve locked with locating ribs (-8° to 120°C).
- Control Shaft:** **[Standard]:** Round Drive Shaft 120 mm, complete with Motor Mounting Plate - HCD32 Kit (HCD23 & 28)
[Optional]:
(1) Hex Extension Shaft 23, 44, 93, or 300 mm, complete with Motor Mounting Plate - HCD 25, 26, 22, or 27, with a HCD 23.
(2) Hex Extension Shaft (93 mm) complete with Quadrant Arm and Plate – HCD31 Kit (HCD22/23/24).
- Blade Rotation:** **[Standard]:** Opposed
[Optional]: Parallel (specify if required).
- Finish:** Mill
- Minimum Size:** 150 mm wide and 155 mm high (Air Stream).
- Maximum Size:** 1200 mm wide and 1775 mm high (Air Stream).
- General:** Nominal size is the duct air stream size. The actual overall size is the air stream size, plus 70 mm.
- Maximum ΔP** 1000 Pa at 1200 mm wide.

For other features contact your local Holyoake branch.

Duct Mounting

The HBD-155 has been specifically designed to be installed using 35mm proprietary duct flanging systems. This means that the damper can be installed in exactly the same way as a piece of flanged duct. This way of mounting the HBD-155 provides an easy installation method and maintains the maximum amount of free area.

The HBD-155 can also be mounted inside a duct in much the same way as an HCD-150 Standard Channel damper.

Balancing Control Damper

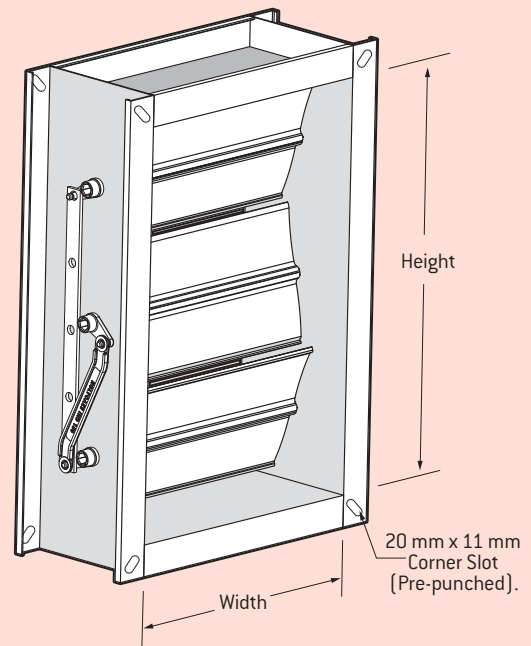

Dimensions

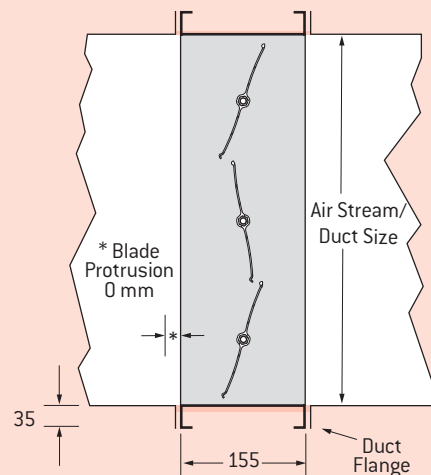

Installation

Dampers must be installed square and free from racking. Typically the method of driving the damper depends on its application. Where the actuator is to be located externally, specify Round Drive Shaft 120 mm. For manual control, use Hex Extension Shafts, Quadrant Arm and Plate. A drive shaft must be fitted to a “power blade” axle on the linkage side of the damper.

Motorised HBD 155 dampers must not be installed with the axles vertical.

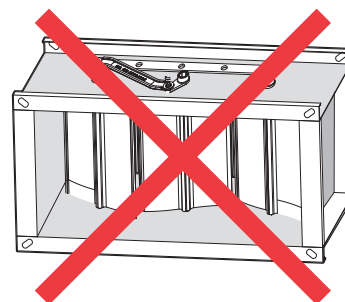

Model: HBD-155

AREA FACTOR TABLE																										
Duct Height (mm)	No. of Blades	Duct Width (mm)																								
		300	350	400	450	500	550	600	650	700	750	800	850	900	950	1000	1050	1100	1150	1200	1250	1300	1350	1400	1450	1500
160	1	23.12	19.81	17.34	15.41	13.87	12.61	11.56	10.67	9.91	9.25	8.67	8.16	7.71	7.30	6.93	6.60	6.30	6.03	5.78	5.55	5.33	5.14	4.95	4.78	4.62
306	2	12.15	10.41	9.11	8.10	7.29	6.63	6.07	5.61	5.21	4.86	4.56	4.29	4.05	3.84	3.64	3.47	3.31	3.17	3.04	2.92	2.80	2.70	2.60	2.51	2.43
452	3	8.24	7.06	6.18	5.49	4.94	4.49	4.12	3.80	3.53	3.30	3.09	2.91	2.75	2.60	2.47	2.35	2.25	2.15	2.06	1.98	1.90	1.83	1.77	1.70	1.65
598	4	6.23	5.34	4.67	4.16	3.74	3.40	3.12	2.88	2.67	2.49	2.34	2.20	2.08	1.97	1.87	1.78	1.70	1.63	1.56	1.50	1.44	1.39	1.34	1.29	1.25
744	5	5.01	4.30	3.76	3.34	3.01	2.73	2.51	2.31	2.15	2.01	1.88	1.77	1.67	1.58	1.50	1.43	1.37	1.31	1.25	1.20	1.16	1.11	1.07	1.04	1.00
890	6	4.19	3.59	3.14	2.79	2.52	2.29	2.10	1.93	1.80	1.68	1.57	1.48	1.40	1.32	1.26	1.20	1.14	1.09	1.05	1.01	0.97	0.93	0.90	0.87	0.84
1036	7	3.60	3.09	2.70	2.40	2.16	1.96	1.80	1.66	1.54	1.44	1.35	1.27	1.20	1.14	1.08	1.03	0.98	0.94	0.90	0.86	0.83	0.80	0.77	0.75	0.72
1182	8	3.16	2.71	2.37	2.11	1.89	1.72	1.58	1.46	1.35	1.26	1.18	1.11	1.05	1.00	0.95	0.90	0.86	0.82	0.79	0.76	0.73	0.70	0.68	0.65	0.63
1328	9	2.81	2.41	2.11	1.87	1.69	1.53	1.41	1.30	1.20	1.12	1.05	0.99	0.94	0.89	0.84	0.80	0.77	0.73	0.70	0.67	0.65	0.62	0.60	0.58	0.56
1474	10	2.53	2.17	1.90	1.69	1.52	1.38	1.27	1.17	1.09	1.01	0.95	0.89	0.84	0.80	0.76	0.72	0.69	0.66	0.63	0.61	0.58	0.56	0.54	0.52	0.51
1620	11	2.30	1.98	1.73	1.54	1.38	1.26	1.15	1.06	0.99	0.92	0.86	0.81	0.77	0.73	0.69	0.66	0.63	0.60	0.58	0.55	0.53	0.51	0.49	0.48	0.46
1766	12	2.11	1.81	1.59	1.41	1.27	1.15	1.06	0.98	0.91	0.85	0.79	0.75	0.70	0.67	0.63	0.60	0.58	0.55	0.53	0.51	0.49	0.47	0.45	0.44	0.42

[All Performance data assumes a flanged connection, where duct dimensions are the same as the open area of the damper].

To determine the pressure drop through a fully open HBD-155, use the following procedure:

1. Find the Area Factor from the table above, enter Duct Width and Height.
2. Determine the Conversion Velocity (CV) by multiplying the Area Factor by the air flow in m³/s [CV = Area Factor x m³/s].
3. Enter the pressure drop chart below with the Area Factor and establish the intersection with the Conversion Velocity (CV) line just determined. Read the pressure drop (Pa) on the left hand side of the chart.

Note: Interpolations while not precise are adequate for most calculations.

Example:

Find the pressure drop across a 600 mm wide x 598 mm high model HBD-155, passing an airflow of 4.0 m³/s.

1. From the table using the interpolation, the Area Factor is 3.12.
2. CV = 4.0 x 3.12 = 12.5.
3. From the chart below, the pressure drop reads 17 Pa.

Guide Product Weights	
HBD 155 Balancing Control Damper	Approximate Weight in Kg
1000 x 500	8.3

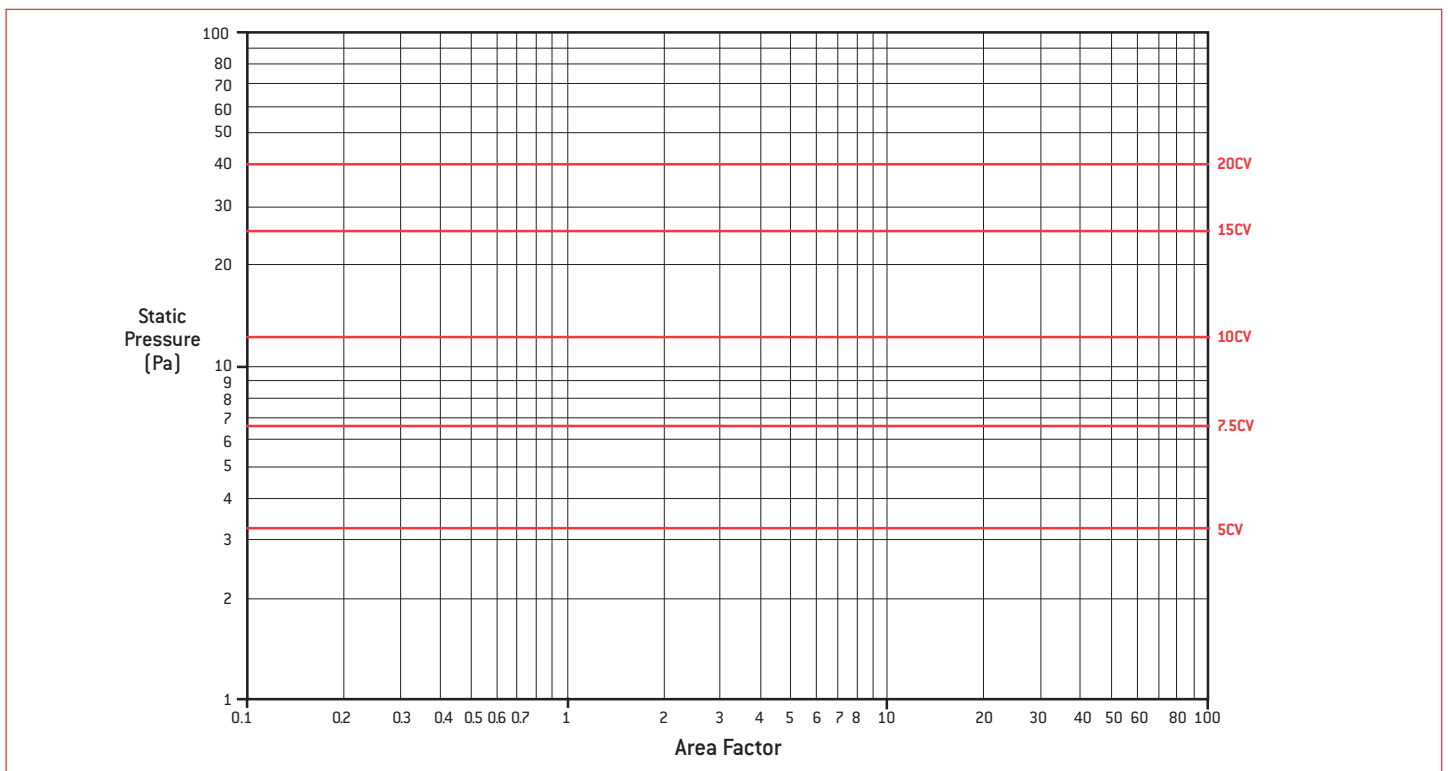

Notes

1. Static Pressure and Conversion Velocities are for air density of 1.2kg/ m³.
2. Pressure drop data is for dampers tested with ductwork on both the up and downstream sides. These values need to be suitably increased where dampers are mounted with ductwork on one side only, or when

mounted onto plenum walls. (Refer to SMACNA, or ASHRAE system design guides).

3. Data is for the specific sizes in the Area Factor Table. For other sizes use the next size down and make a proportional adjustment based on the approximate increase in free area.

HBD & HCD

Product Ordering Key and Suggested Specifications

HBD-155

Holyoake
Balancing
Dampers with
155 mm
Aluminium
Blades

**OPPOSED
PARALLEL**

Blade Rotation:
Opposed (Standard)
Specify Parallel

W x H

Nominal
Duct
Size

CONTROL

Quadrant Arm and Plate.
Round Drive Shaft 120 mm.
Hex Ext Shaft,
(23, 44, 93 or 300 mm).

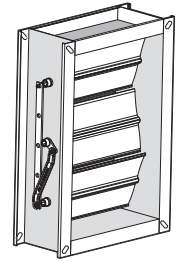

Balancing Dampers shall be of extruded aluminium construction. Frames shall be suitable for duct flange mounting. Blades shall be fixed to 11 mm hexagonal shafts held by two piece acetal self lubricating bearings, with outer shells fluted to prevent rotation.

Linkages shall be out of the airstream. The damper may be furnished with a manual locking quadrant arm, a round shaft and plate, or a hexagonal shaft and plate, suitable for actuator mounting.

All shall be type HBD-155 as manufactured by Holyoake.

**HCD-75
HCD-150**

Holyoake
Control
Dampers
with 75 or
150 mm
aluminium
airfoil blades.

**CHANNEL
LOW PROFILE CHANNEL
FLANGE SURROUND**

Frame
Style

**OPPOSED
PARALLEL**

Blade Rotation:
**Opposed
(Standard)** Specify
Parallel

W x H

Nominal
Duct
Size

CONTROL

Quadrant Arm and Plate.
Round Drive Shaft 120mm.
Hex Ext Shaft,
(23, 44, 93, or 300 mm).

**SPECIAL
CONSTRUCTION
OPTIONS**

For smoke damper see
page 328H - 329H

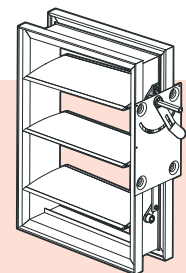

Volume Control Dampers shall be low leakage type extruded aluminium construction, with single piece airfoil blades, fitted with self inflating edge seals. Blades shall be fixed to 11 mm hexagonal shafts, held by two piece acetal self lubricating bearings, with outer shells fluted to prevent rotation. Frames shall be suitable for either internal fixing within ductwork, or external duct flange mounting and shall be fitted with flexible aluminium side seals. Linkages shall be out of the airstream. Leakage shall be no greater than 0.04 m³/s/m² at 1500 Pa Δp, or typically 0.45 % of full flow (at 5 m/s) with 500 Pa Δp. The damper may be furnished with a manual locking quadrant arm, a round shaft and plate, or a hexagonal shaft and plate, suitable for actuator mounting.

All shall be type HCD-75, or HCD-150, as manufactured by Holyoake.

HCD-225

Holyoake
Heavy Duty
Control
Dampers
with 225 mm
Airfoil Blades

PARALLEL

Blade Rotation
(No Opposed
Option)

W x H

**Nominal
(Overall Size)**

CONTROL

Electric Motor,
Pneumatic Actuator,
(Further discussion
required with local
Holyoake branch).

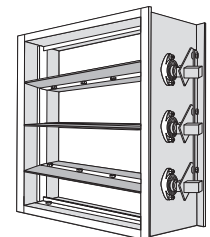

Heavy Duty Volume Control Dampers shall be constructed from extruded aluminium. Frames shall be suitable for duct flange mounting and be 6 mm thick. Blades shall be Parallel Airfoil 3 mm thick, with internal strengthening and fitted with externally mounted Heavy Duty Spherical Ball Bearings. Axle crank plates shall be 55 x 6 mm mild steel plate, with brass bearings; mounted outside of the airstream, providing a robust, long lasting operating mechanism, able to handle high turbulence/pressure and velocity. The damper shall be available with a range of control options to suit specialist applications.

All shall be type HCD-225 as manufactured by Holyoake.



RELIEF DAMPERS

BDE	Back Draft Dampers	316 - 318H
PRD - 150	Heavy Duty Pressure Relief Dampers	319 - 320H
Ordering Key and Specification		321H

- Extruded Aluminium Construction.
 - Light Duty Pressure Relief.
 - Heavy Duty Back Draft.
 - Range of Flange and Casing options.
 - Tension Spring and Blade Weight options.
-

BDE – Back Draft Damper

Model: BDE

The Holyoake Model BDE is a light duty pressure relief damper constructed of extruded aluminium.

It operates at low opening pressure differential and with minimal leakage when closed against reverse flow.

Standard Construction

Frame Options:

- (1) Front flange mounting (Small).
- (2) Rear flange mounting (Small).
- (3) Channel frame: Flange is removed for channel mounting.
- (4) Duct flange: For connecting to a 25 mm proprietary flange system.
- (5) Front flange mounting (Large).
- (6) Rear flange mounting (Large).

Blades: 6063 T5 extruded aluminium with flexible vinyl blade edge seal (0-80°C).

Linkage Bar: 1.6 x 13 mm aluminium bar, fixed to all blades at one end, to avoid flutter.

Axles & Cranks: Moulded acetal, (-8-+120°C) left and right handed with integral pivot pins for both blade support and interconnecting linkage.

Finish: Mill.

Minimum Size: 150 mm Wide x 150 mm High Nominal Duct Size.

Maximum Size: 1000 mm Wide x 1140 mm High Nominal Duct Size, (Single Section).

Maximum Velocity: 5 m/s AVERAGE, 7.5 m/s SPOT

Options (at additional cost):

Tensions Springs: (A) Normal. Tension spring to provide **adjustable resistance** to airflow.

(B) Inverted. Tension spring to provide **adjustable resistance** to airflow. Blades reversed.

(C) Horizontal. Tension spring to provide **adjustable opening assistance** when used in the horizontal plane for upward airflow.

Not available for downward airflow.

Features

- Aluminium Construction
- Vertical, or Horizontal mounting (Blades must always be horizontal).
- Vinyl blade edge seal.
- Linked blades, to avoid flutter.
- Gravity operation.

Options

- Duct flange, or Channel frame.
- Front, or Rear Flange.
- Large, or Small Flange.
- Tension Springs.

Back Draft Damper

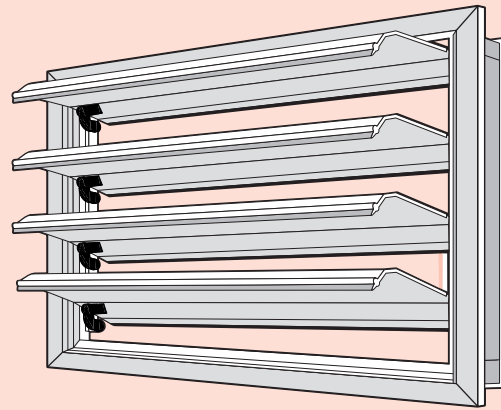

Pressure Relief

When used as a pressure relief device, there are two orientation options, vertical and horizontal, neither requiring resistance springs.

However, on horizontal units, tension springs can be added to provide adjustable opening assistance for upwards airflow, to help overcome the additional blade weight incurred in that position. Factory calibration is not available and these units are only for adjustment in the field by the purchaser.

Although not a precision device, the Holyoake BDE can provide a simple solution to pressure relief problems, within the parameters indicated in the Standard Vertical Orientation data.

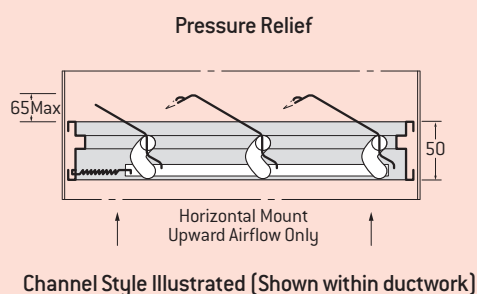
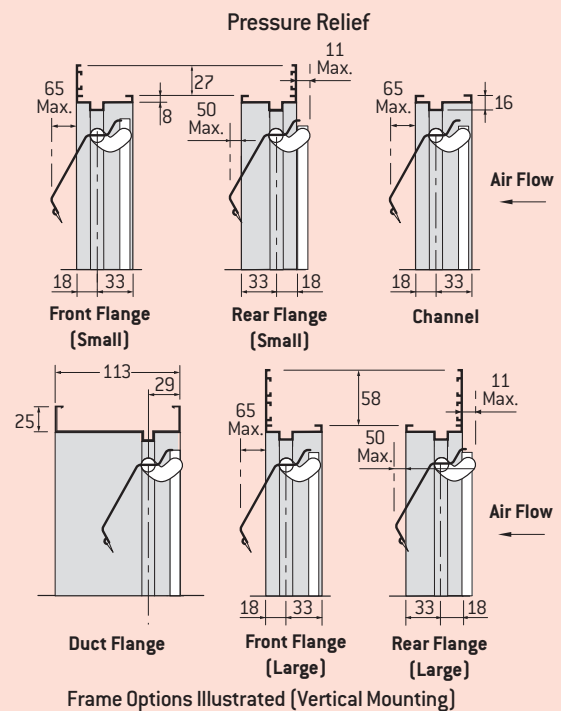

Model: **BDE**

Pressure Control

When used as an upstream pressure control device, there are two orientation options, both vertical and both using resistance springs.

Normal: Maximum opening static pressure is adjustable between 50 and 100 Pa at maximum flow. Pressure tends to vary with flow.

Inverted: Maximum opening static pressure is adjustable between 19 and 66 Pa. Pressure tends to remain constant as flow varies.

The Holyoake BDE is not a precision device and factory calibration is not available. These units are only for adjustment in the field by the purchaser. However, they can provide a simple solution to pressure control problems within the parameters indicated in the relevant performance data.

Before ordering for pressure control, consult your local Holyoake branch. It is important that only complete blade modules are used, with trailing edges intact.

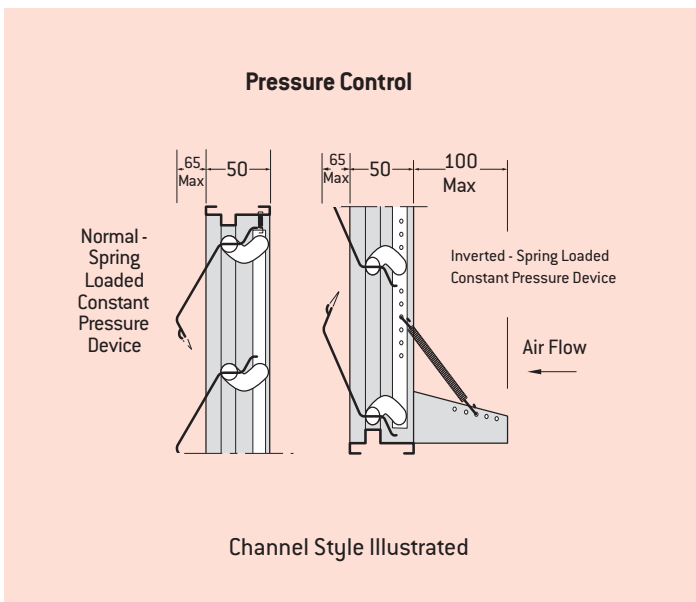
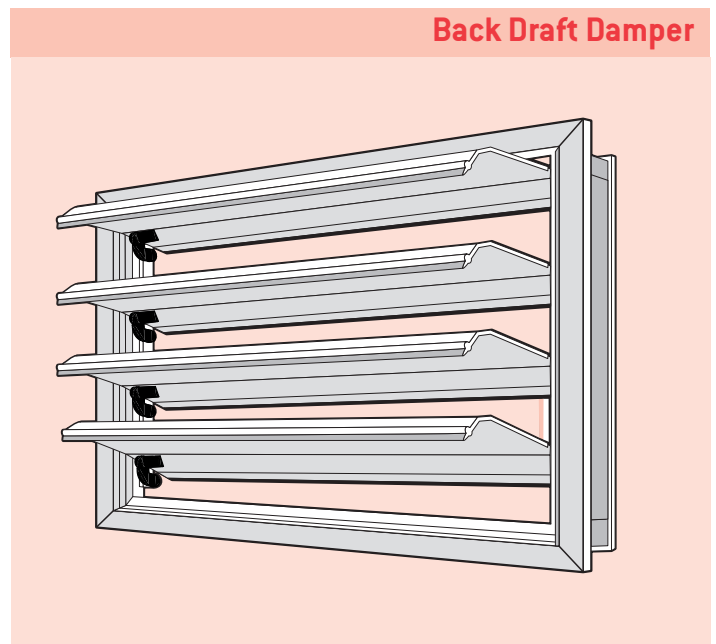

BDE shutters must not be installed with the axles vertical.

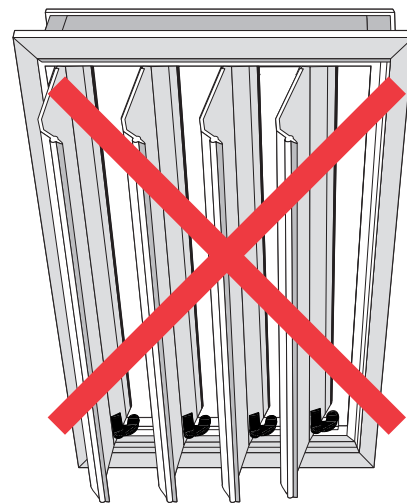

Installation

When ordering, Nominal duct dimensions are required, Width (Blade Length) x Height.

A 7 mm clearance is allowed in manufacture to enable dampers to be inserted within ductwork, (except Duct Flange units which are Nominal Airstream Sizes).

Where used in fan discharge applications, allow adequate distance for turbulence to reduce, e.g. for axial flow fans, or for centrifugal fans, mount five impeller diameters downstream from the fan outlet.

Install square and free from racking.

Do not rely upon BDE back draft dampers for weather resistance. Where required in an outside wall, use in conjunction with OHL series weather louvers.

Guide Product Weights	
BDE Back Draft Damper	Approximate Weight in Kg
300 x 300 (Small Channel)	1.02
1000 x 1000 (Small Channel)	11.33 per m ²

Mounted in Vertical Position in Standard Orientation

Duct Height (mm)	Flowrate (l/s)	Nom duct Vel (m/s)	No Spring P _s (Pa)	Spring Pos for Max Tension P _s (Pa)	FLOWRATE (l/s)				
					Duct Width (mm)				
					150	250	500	750	1000
150	Min	0.2	10	30	5	8	15	23	30
	Max	5.0	50	100	113	188	375	563	750
240	Min	0.2	10	30	7	12	24	36	48
	Max	5.0	50	100	180	300	600	900	1200
340	Min	0.2	10	30	10	17	34	51	68
	Max	5.0	50	100	255	425	850	1275	1700
440	Min	0.2	10	30	13	22	44	66	88
	Max	5.0	50	100	330	550	1100	1650	2200
540	Min	0.2	10	30	16	27	54	81	108
	Max	5.0	50	100	405	675	1350	2025	2700
640	Min	0.2	10	30	19	32	64	96	128
	Max	5.0	50	100	480	800	1600	2400	3200
740	Min	0.2	10	30	22	37	74	111	148
	Max	5.0	50	100	555	925	1850	2775	3700
840	Min	0.2	10	30	25	42	84	126	168
	Max	5.0	50	100	630	1050	2100	3150	4200
940	Min	0.2	10	30	28	47	94	141	188
	Max	5.0	50	100	705	1175	2350	3525	4700
1040	Min	0.2	10	30	31	52	104	156	208
	Max	5.0	50	100	780	1300	2600	3900	5200
1140	Min	0.2	10	30	34	57	114	171	228
	Max	5.0	50	100	855	1425	2850	4275	5700

Mounted in Vertical Position in Inverted Orientation

Duct Height (mm)	Flowrate (l/s)	Nom duct Vel (m/s)	Spring Pos for Min Tension P _s (Pa)	Spring Pos for Max Tension P _s (Pa)	FLOWRATE (l/s)				
					Duct Width (mm)				
					150	250	500	750	1000
150	Min	0.2	19	40	5	8	15	23	30
	Max ¹	3.3	25		74	124	248	371	495
	Max	5.0		66	113	188	375	563	750
240	Min	0.2	19	40	7	12	24	36	48
	Max ¹	3.3	25		119	198	396	594	792
	Max	5.0		66	180	300	600	900	1200
340	Min	0.2	19	40	10	17	34	51	68
	Max ¹	3.3	25		168	281	561	842	1122
	Max	5.0		66	255	425	850	1275	1700
440	Min	0.2	19	40	13	22	44	66	88
	Max ¹	3.3	25		218	363	726	1089	1452
	Max	5.0		66	330	550	1100	1650	2200
540	Min	0.2	19	40	16	27	54	81	108
	Max ¹	3.3	25		267	446	891	1337	1782
	Max	5.0		66	405	675	1350	2025	2700
640	Min	0.2	19	40	19	32	64	96	128
	Max ¹	3.3	25		317	528	1056	1584	2112
	Max	5.0		66	480	800	1600	2400	3200
740	Min	0.2	19	40	22	37	74	111	148
	Max ¹	3.3	25		366	611	1221	1832	2442
	Max	5.0		66	555	925	1850	2775	3700
840	Min	0.2	19	40	25	42	84	126	168
	Max ¹	3.3	25		416	693	1386	2079	2772
	Max	5.0		66	630	1050	2100	3150	4200
940	Min	0.2	19	40	28	47	94	141	188
	Max ¹	3.3	25		465	776	1551	2327	3102
	Max	5.0		66	705	1175	2350	3525	4700
1040	Min	0.2	19	40	31	52	104	156	208
	Max ¹	3.3	25		515	858	1716	2574	3432
	Max	5.0		66	780	1300	2600	3900	5200
1140	Min	0.2	19	40	34	57	114	171	228
	Max ¹	3.3	25		564	941	1881	2822	3762
	Max	5.0		66	855	1425	2850	4275	5700

¹ Blades are fully open at 3.3 m/s. Note: Velocities at nominal (approach duct) area.

Medium Duty Back Draft Damper – BDE100

Model: BDE100

The Holyoake BDE100 is a **Medium Duty** back draft, pressure relief, or non-return damper. Constructed from extruded aluminium and stainless steel components, with a single blade seal and side seal, it is capable of handling high turbulent air velocities and provides minimal leakage when closed against reverse flow.

Standard Construction

- Frame:** 6063 T5 extruded aluminium, mechanically joined with screws through screw pipes.
- Blades:** 6063 T5 extrusion for main blades on 100mm centres; bottom weir used for intermediate heights.
- Linkage:** Concealed in frame, with stainless steel cranks and link pins, and extruded control bars.
- Axles:** Hexagonal stainless steel.
- Bearings:** Two piece moulded glass reinforced nylon, pressed into frame, with the outer sleeve locked with locating ribs (-8°C – 220°C).
- Blade Seal:** Extruded EDPM (0°C – 80°C).
- Control Shaft:** 304 stainless steel hexagonal shaft complete with control plate.
- Blade Rotation:** Parallel only.
- Finish:** Mill standard, anodised, and powder-coat options available.
- Minimum Size:** Flanged Surround 150mm Wide x 100mm High (Airstream).
Channel Surround 200mm Wide x 150mm High (Nominal).
- Maximum Single Unit Size:** Flanged Surround 1200mm Wide x 1800mm High (Airstream).
Channel Surround 1250mm Wide x 1850mm High (Nominal).

Features

- Medium duty robust blades.
- Aluminium and stainless steel construction.
- Vertical, or horizontal mounting (blades must always be horizontal).
- Aluminium blade side seal.
- Linked blades (to avoid flutter).
- Gravity operation.

Special Construction Options

- Frame:**
- (1) Flanged 25mm* - square cut ends
 - (2) Flanged 35mm* - square cut ends
 - (3) Channel - mitred corners
- Balancing:**
- (1) Counterweights**
 - (2) Tension springs
- Elevated Temperatures:** High temperature blade seals (max 225°C).

* This frame has been designed to couple with proprietary flange systems.
** Ganged together to set desired opening pressure.

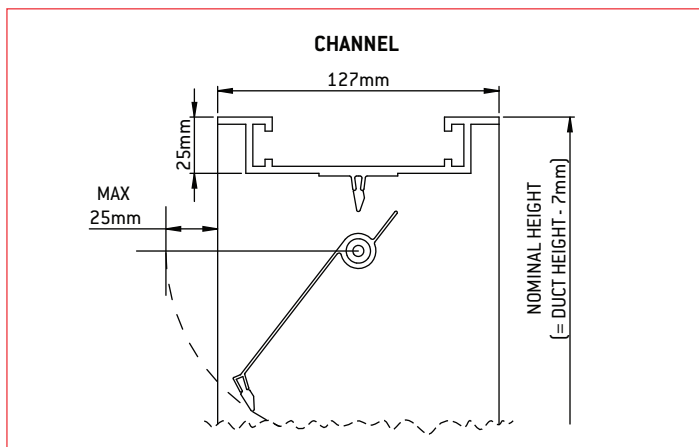
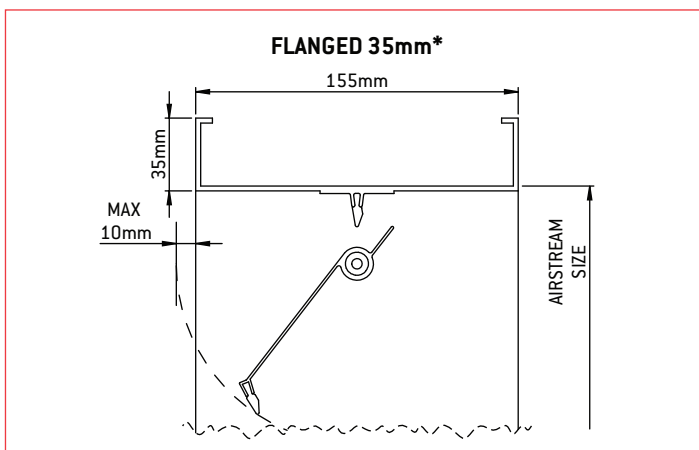
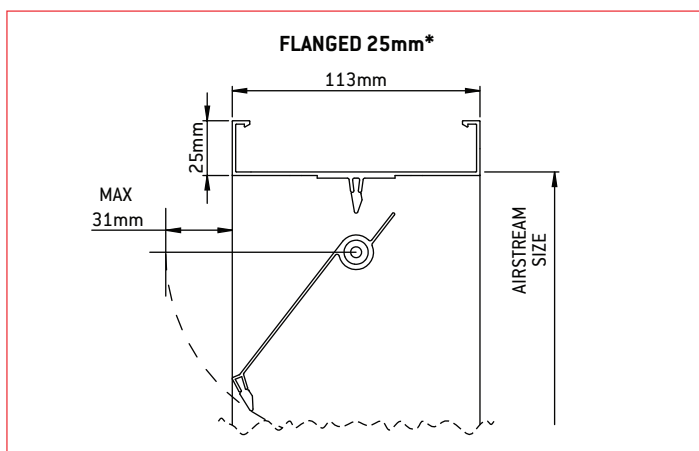
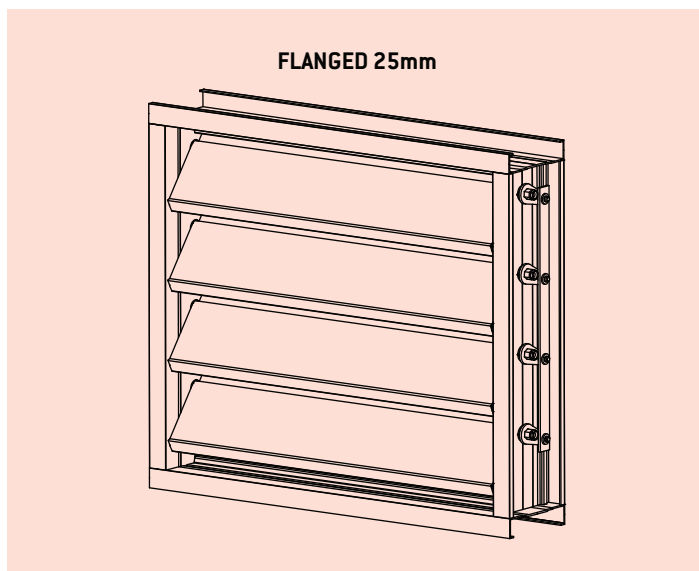

BDE100 – Medium Duty Back Draft Damper

Model: **BDE100**

Pressure Control

To maintain pressure control the blades remain closed under gravity. To increase the opening pressure weights and springs can be added to the control shaft via a lever arm. Weights can be ganged together to set desired opening pressure. Dashed lines show blades and weights in an open position.

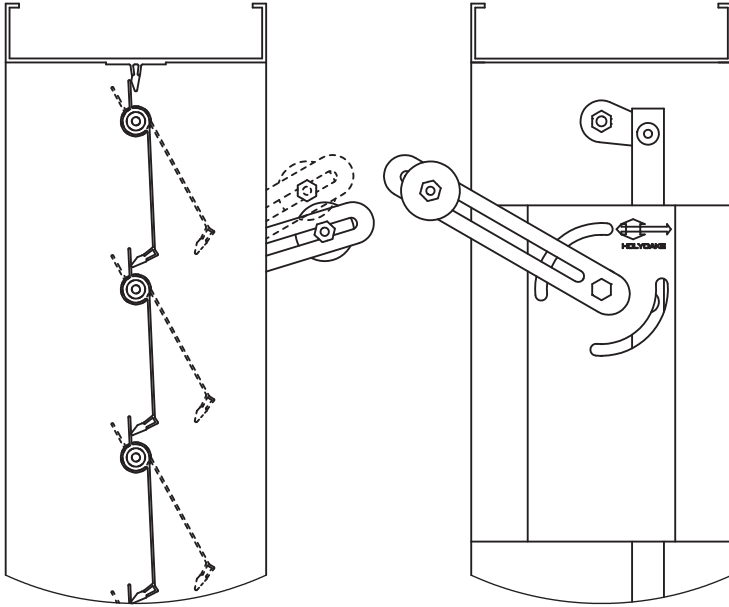

Factory calibration is not available; the correct amount of weight, with optional tension springs, is determined by on site commissioning by others.

Although not a precise device this can provide a simple solution to pressure control problems within the parameters indicated below, or the product can be purely utilised as a back draft, or non return valve.

Before ordering a BDE100 please consult your local Holyoake branch to discuss selection criteria.

Installation

BDE100 dampers must NOT be installed with the blades vertical.
BDE100 dampers must NOT be mounted in the 'inverted' position.

Install square and free from racking.

Flanged versions are installed between ducts, so airstream sizes apply.

Channel versions are installed inside ducts, so nominal sizes apply.

Where used in close proximity to fans, ensure that turbulence does not cause the damper to exceed the maximum velocities (AVERAGE or SPOT).

Maximum Velocity: 10m/s AVERAGE, 12m/s SPOT

Do not use the BDE100 as a weather proof louver. When mounted in external walls they should be installed in conjunction with Holyoake OHL series outside louvers, detailed in Section F.

When BDE100 dampers are mounted horizontally (floor mounted) only upwards airflow can be accommodated.

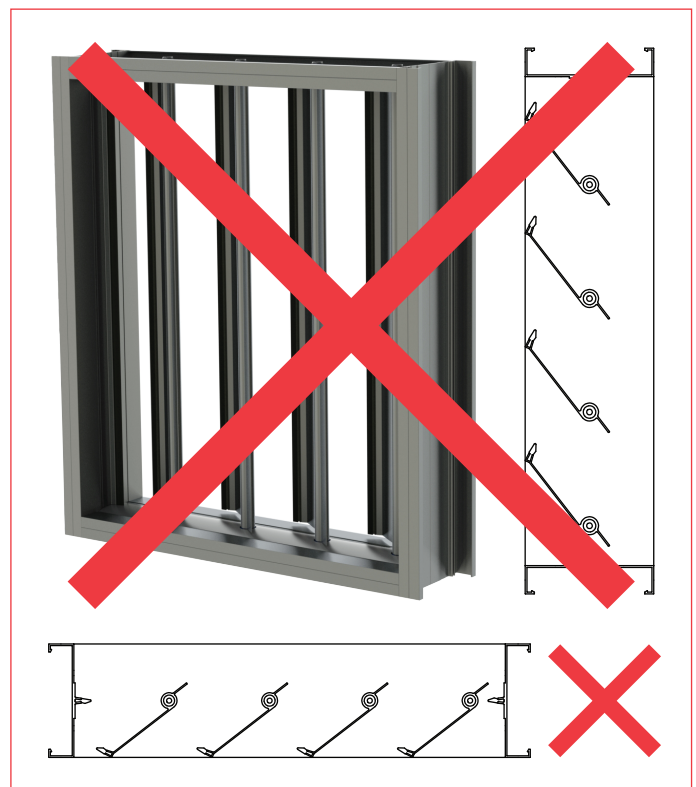
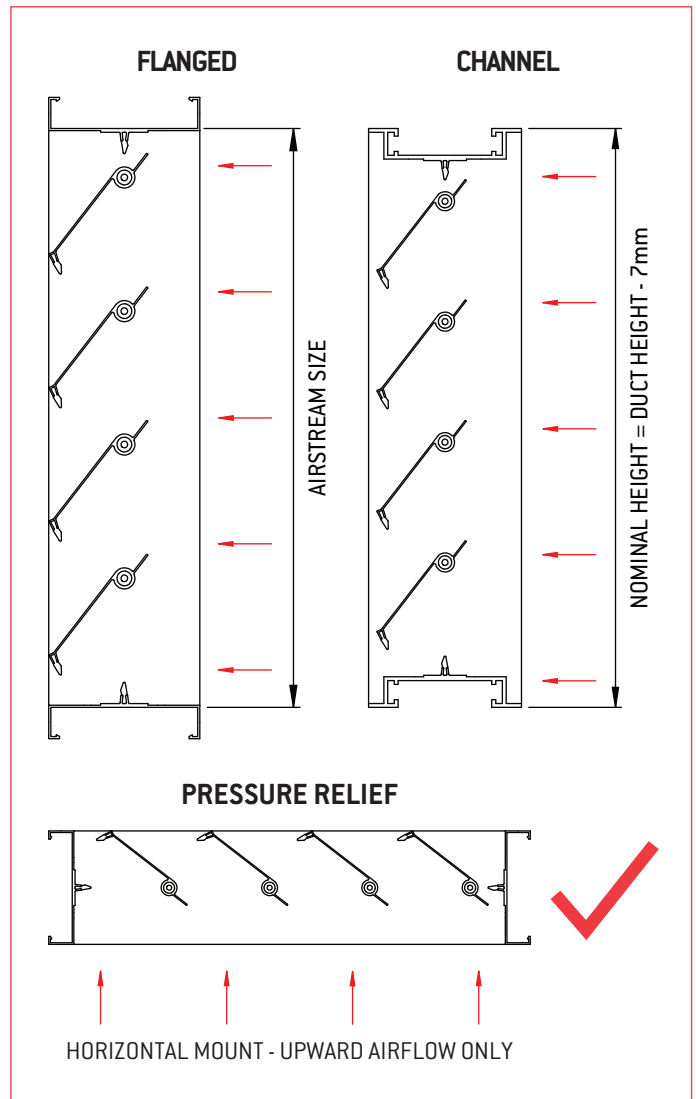

Heavy Duty Pressure Relief Damper – PRD-150

Model: PRD-150

The Holyoake PRD -150 is a **Heavy Duty** pressure relief, back draft, or non return damper. Constructed from extruded aluminium, with twin blade seals and side gaskets; it is capable of handling high turbulent air velocities and provides minimal leakage when closed against reverse flow.

Standard Construction

- Frame Options:** (1) **Duct Flange** - Square cut ends.
 (2) **Channel Frame** - Mitred corners.
 Both from 6063 T5 extruded aluminium, mechanically locked with heavy duty fixings.
- Blades:** 6063 T5 cavity extrusion providing partial airfoil section.
- Linkage:** Concealed in frame, with stainless steel link pins and aluminium control bars.
- Axles & Cranks:** Hexagonal.
- Bearings:** Two piece moulded glass reinforced nylon, pressed into frame, with the outer sleeve locked with locating ribs (-8 - 220°C).
- Blade Seal:** Extruded EPDM (0-80°C).
- Side Seal:** Flexible (convex) aluminium.
- Control Shaft:** Hexagonal shaft complete with control plate.
- Blade Rotation:** Parallel only
- Finish:** Mill standard, anodized and powercoat options available.
- Minimum Size:** Duct Flange 150 mm Wide x 176 mm High (Airstream size)*.
 Channel Frame 200 mm Wide x 232 mm High (Nominal, overall case size)*.
- Maximum Size:** Duct Flange 750 mm Wide x 1490 mm High (Airstream size)*.
 Channel Frame 800 mm Wide x 1546 mm High (Nominal, overall case size)*.

*** Important: Only complete blade module heights can be ordered, see table overleaf.**

Features

- Heavy Duty Robust blades.
- Aluminium Construction.
- Vertical, or Horizontal mounting (Blades must always be horizontal).
- Twin blade edge seals.
- Aluminium blade side seal gaskets.
- Linked blades, to avoid flutter.
- Gravity operation.

Options

- Duct flange, or channel frame.
- Blade adjustment weights.
- High temperature blade seals (Max 225°C).

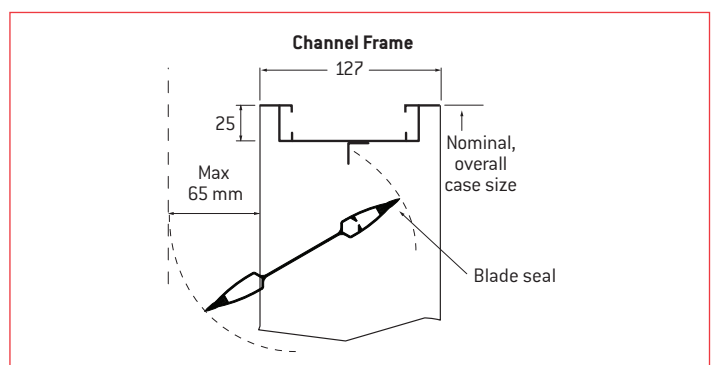
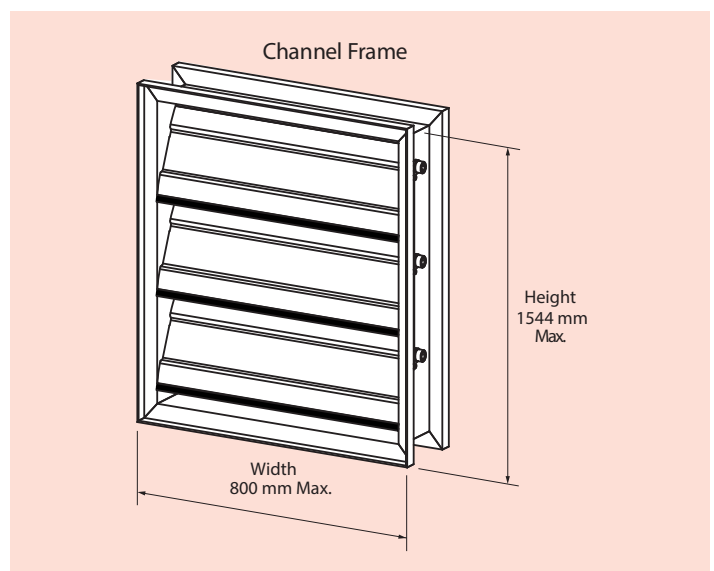
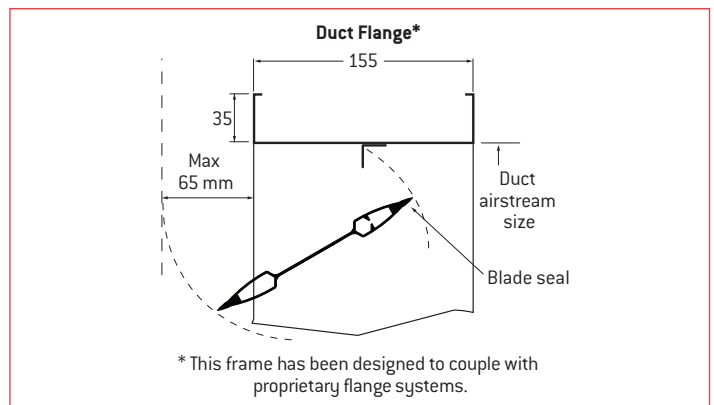
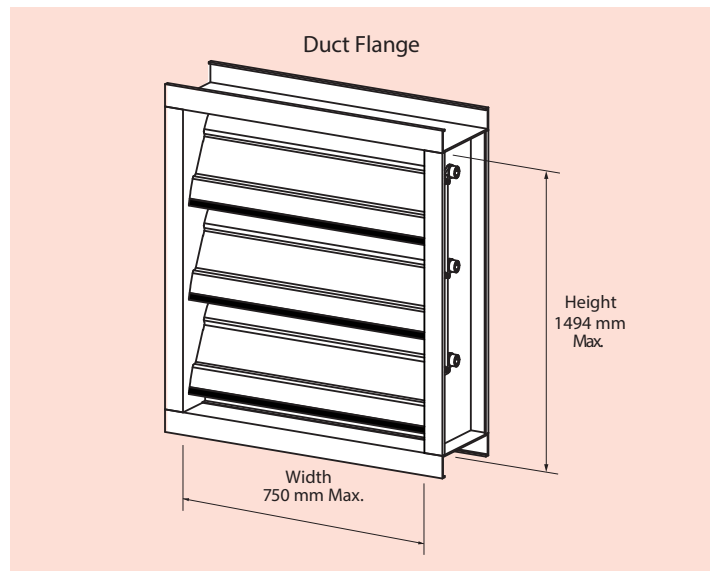

PRD-150 – Performance Data

Model: **PRD-150**

Pressure Control

To maintain pressure control the blades remain closed under gravity. To increase the opening pressure, weights can be added to the control shaft, via a lever arm. (Weights are not certified). Factory calibration is not available; therefore, the correct amount of weight and adjustment is determined by on site commissioning, by others.

Although not a precise device this can provide a simple solution to pressure control problems within the parameters indicated above, or the product can be purely utilised as a back draft, or non return valve.

Before ordering a PRD 150 please consult your local Holyoake branch to discuss selection criteria.

Installation

PRD 150 dampers must not be installed with the axes vertical.

PRD 150 dampers must not be mounted in the 'Inverted' position.

Install square and free from racking.

Flanged versions are installed between ducts, so airstream sizes apply.*

Channel versions are installed inside ducts, so nominal sizes apply.*

When used in close proximity to fans, ensure that turbulence does not cause the damper to exceed the maximum velocities (AVERAGE or SPOT).

Maximum Velocity: 15 m/s AVERAGE, 20 m/s SPOT.

Maximum Pressure: 1100 Pa.

Minimum Opening Static Pressure: 30 Pa (Blade Weight Only).

Do not use the PRD 150 as a weather proof louver. When mounted in external walls they should be installed in conjunction with Holyoake OHL series outside louvers, detailed in section F.

*** Important: Only complete blade module heights can be ordered, see table below:**

*Full Blade Height Dimensions		
Number of Blades	Air Stream Height, Flanged versions	Nominal Height, Channel versions
1	176	232
2	322	378
3	468	524
4	614	670
5	760	816
6	906	962
7	1052	1108
8	1198	1254
9	1344	1400
10	1490	1546

For Airflow Performance and to check suitable sizing, please refer to the HCD 150 performance data on page 304H and 305H. Performance of a given sized PRD 150 is directly proportional to 90 % of the same sized HCD 150. To check PRD 150 size, take the given air flow, add 10% (x1.1) and select size from the relevant HCD 150 section. Ensure the height matches a complete module height, refer to the table above.

Increased opening static pressures can be achieved by adding weight to one of the blades, (lever arm and weights are optional extras, weights are not certified).

The correct amount of weight is determined by on site commissioning (carried out by others).

When PRD 150 dampers are mounted horizontally (floor mounted); upwards airflow only can be accommodated.

Guide Product Weights	
PRD 150 Pressure Relief Damper	Approximate Weight in Kg
500 x 325 Airstream Size	4.4

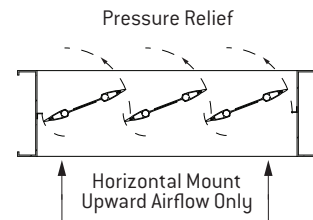
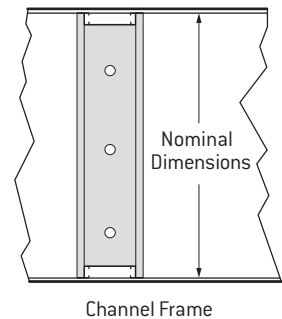
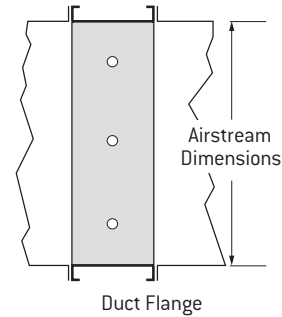
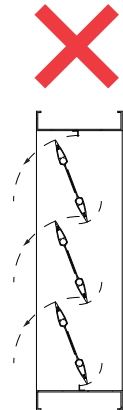
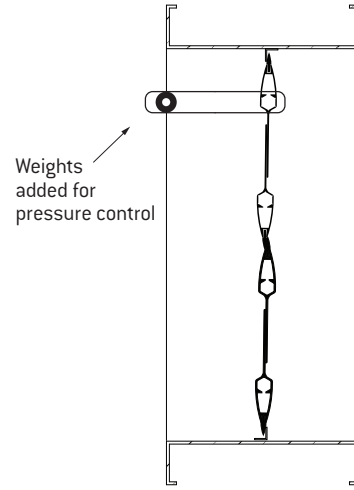

Product Ordering Key and Suggested Specifications

BDE	FRAME STYLE	W x H	OPTIONS
Back Draft Damper with Extruded Blade	C - Channel Frame DF - Duct Flange FFL - Front Flange - Large FFS - Front Flange - Small RFL - Rear Flange - Large RFS - Rear Flange - Small	Nominal Duct Size	Tension Springs (Normal, Inverted, or Horizontal)

Back Draft Dampers shall be constructed from extruded aluminium.

Frames shall have mitred corners, be mechanically locked with aluminium gussets and be suitable for internal fixing within ductwork, or have square cut ends and be mechanically joined with screws tapped into screw pipes, for external duct flange mounting.

Blades shall be extruded aluminium with vinyl edge seal and shall be freely pivoted in the frame on moulded acetal cranks and bearing pins, linked by a gang bar, to operate in unison.

All shall be type BDE as manufactured by Holyoake.

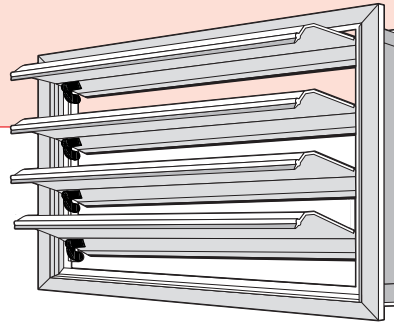

PRD -150	FRAME STYLE	W x H	Pa	OPTIONS
Heavy Duty Pressure Relief Damper	C - Channel Frame * DF - Duct Flange +	Nominal Overall Case Size* Nominal Duct Size (Airstream)+	Opening Pressure Required	Lever Arm and Blade Weights. High Temperature Version (Max 210C).

Heavy Duty Pressure Relief Dampers shall be constructed from extruded aluminium.

Frames shall have mitred corners, be mechanically locked with aluminium gussets and be suitable for internal fixing within ductwork, or have square cut ends and be mechanically joined with screws tapped into screw pipes, for external duct flange mounting.

Blades shall be extruded aluminium with acetal edge seals both sides and be complete with aluminium side seal gaskets. They shall be linked by an aluminium gang bar, to operate together in unison. They shall freely pivot in the frame, on aluminium cranks and axles, within moulded acetal bearings. (Blade adjustment weights may be added if required, via a spindle control bar).

All shall be type PRD -150 as manufactured by Holyoake.

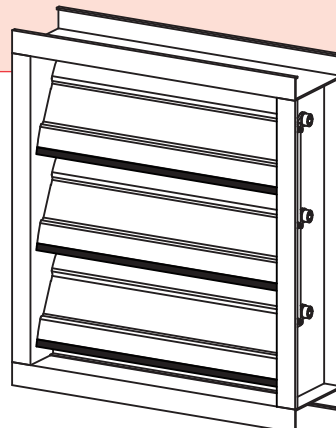



IBD-FS Undergoing certification testing

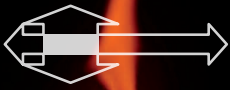

FIRE & SMOKE DAMPERS

HCD

Smoke Damper
Aluminium low leakage airfoil smoke damper

328 - 329H

HCD ET – Elevated Temperature Smoke Damper

Model: HCD - 150/75 - ET

The Holyoake HCD ET is a elevated temperature version of the HCD-150 or HCD -75 volume control dampers. It is suited for tight sealing smoke damper installations.

It offers great structural strength and very low resistance when open.

Smoke damper rating:

As required for a smoke damper under AS1682.1-2015 the HCD-150 ET has been tested to AS1530.7-2007.

The air leakage of the damper is tested at 200°C and must be under 360m³/hr/m² at 300 Pa.

• Warringtonfire

Summary of Assessment No. SOA-47931300

Ambient & Medium Temperature Air Leakage Test in accordance with AS 1530.7-2007 on an Holyoake HCD ET Smoke Damper.

HCD ET installed either into smoke separating wall or ducted within 600mm from the wall opening.

Maximum leakage @300 Pa

Ambient	91m ³ /hr/m ²
Elevated Temperature (@ SRC)	118 m ³ /hr/m ²

• Warringtonfire

Certificate of Test No. FRT-210015

Operation of the HCD-ET after two hours at 200°C as per the performance requirements of AS 1682.1 Table 5 for Air Dampers.

HCD-150 Standard Construction

Frame: 6063 T5 extruded aluminium with mitred corners, mechanically locked with heavy aluminium gussets.

Blades: 6063 T5 three cavity full airfoil extrusion for main blades on 146 mm centres and half airfoil part blade for intermediate heights.

Linkage: Concealed in frame, with stainless steel cranks and steel link pins and aluminium control bars.

Axles: Hexagonal.

Bearings: Two piece moulded glass reinforced nylon, pressed into frame, with the outer sleeve locked by locating ribs. (-8°C to 220 °C)

Seals: Blade edge and Jamb: Extruded silicone, (0°C to 225°C).
Side Seal: Flexible (convex) aluminium.

Blade Rotation: Opposed

Finish: Mill.

Minimum Size: Channel Surround 200 mm Wide x 225 mm High.
Flange Surround 150 mm Wide x 168 mm High.
(Air Stream).

Maximum Size: Channel Surround 1525 mm Wide x 1831 mm High.
Flange Surround 1400 mm Wide x 1774 mm High.
(Air Stream).

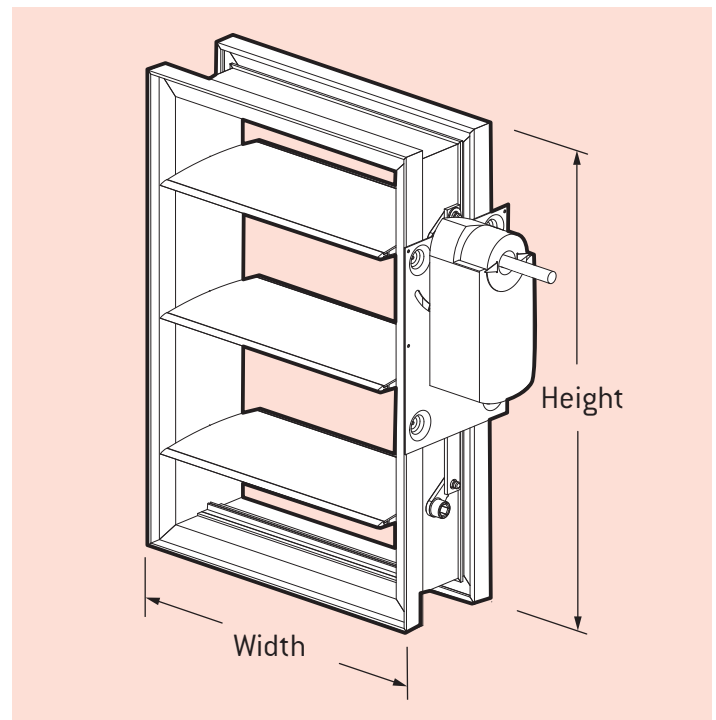

HCD-75 Standard Construction

Frame: 6063 T5 extruded aluminium with square cut ends, mechanically joined with screws tapped into screw pipes.

Blades: 6063 T5 three cavity extrusion providing a full airfoil section.

Linkage: Concealed in frame, with stainless steel cranks and link pins and aluminium control bars.

Axles: Hexagonal stainless steel.

Bearings: Two piece moulded glass reinforced nylon, pressed into frame, with the outer sleeve locked with locating ribs (-8° to 220°C).

Seals: Blade edge & Jamb: Extruded silicone, (0°C to 225°C).
Side Seal: Flexible (convex) aluminium.

Blade Rotation: (Standard): Opposed

Finish: Mill.

Minimum Size: 150 mm wide and 95 mm high (Air Stream).

Maximum Size: 950 mm wide and 898 mm high (Air Stream).

General: The specified size is the duct airstream size. The actual overall size is the airstream size plus 50 mm.

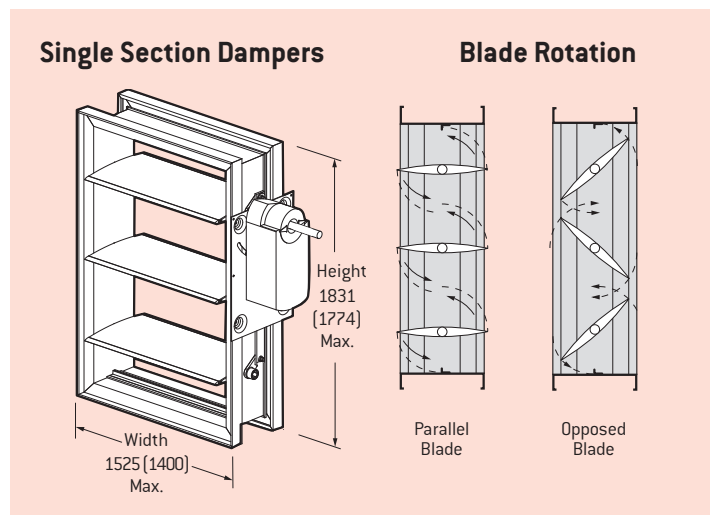

Elevated Temperature Smoke Damper – HCD-ET

Installation

Smoke dampers can be installed up to 600mm away from the smoke barrier and must be installed with smoke resistant ductwork. The duct penetration should be sealed with flanges and the sealant used should be suitable for elevated temperatures (200°C). The flanged HCD ET damper surround has been designed specifically for use with proprietary duct flanging systems.

Smoke dampers may be installed in either vertical or horizontal applications, but in all cases the blade axles must be horizontal. Smoke dampers must be fitted with fast running actuators with a travel time less than 30s in either direction and capable of closing under the design airflow. This can be either spring return or driven closed by a building management system (BMS).

The installer must ensure that the damper is installed square and free from racking but should be effectively retained so it can not be dislodged during normal use. Smoke dampers do not require the use of breakaway joints when being used solely as a smoke damper.

For more information see AS1682.2 clause 6.2 and Appendix B.

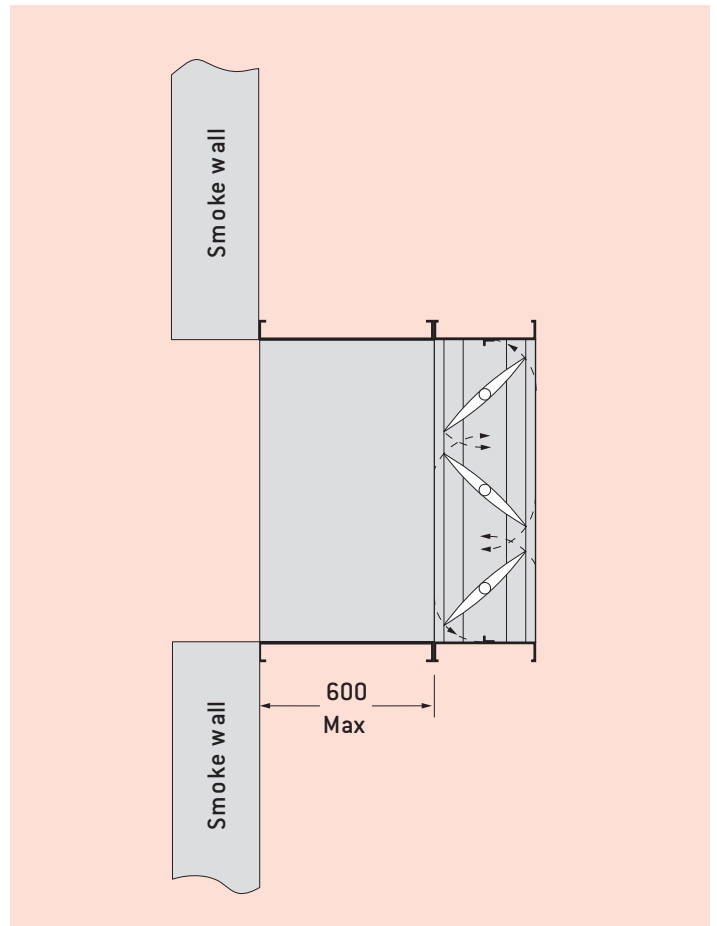
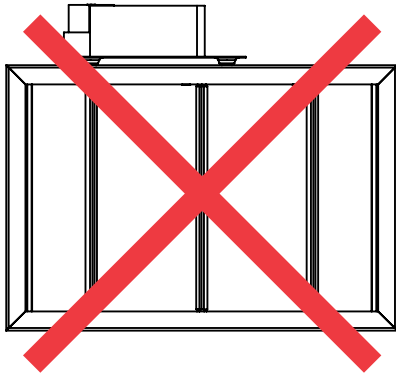

Notes

Motorised HCD-ET dampers must not be installed with the axes vertical.

Due to a policy of continuous development and improvement the right is reserved to supply products which may differ slightly from those illustrated and described in this publication.

Product Ordering Key and Suggested Specifications

HCD-ET-75 HCD-ET-150	-	CHANNEL LOW PROFILE CHANNEL FLANGE SURROUND	-	OPPOSED PARALLEL	-	W x H
Holyoake Smoke Dampers with 75 or 150 mm aluminium airfoil blades.		Frame Style		Blade Rotation: Opposed (Standard) Specify Parallel		Nominal Duct Size

Smoke Dampers shall be low leakage type extruded aluminium construction, with single piece airfoil blades, fitted with self inflating edge seals. Blades shall be fixed to 11 mm hexagonal shafts, held by two piece acetal self lubricating bearings, with outer shells fluted to prevent rotation. Frames shall be suitable for either internal fixing within ductwork, or external duct flange mounting and shall be fitted with flexible aluminium side seals. Linkages shall be out of the airstream. Smoke dampers shall be tested to AS1530.7-2007 and have a leakage less than 360 m³/s/m² at 300Pa and 200°C.

All shall be type HCD-75, or HCD-150, as manufactured by Holyoake.

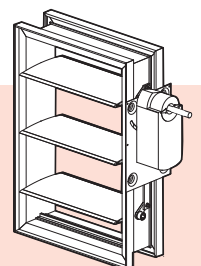

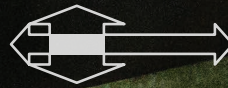

FIRE & LEAKAGE RATED DAMPERS

LR**Round combination Fire and Smoke Damper**

Innovative Single Blade Fire and Smoke Damper

Manual and Motorised options

331 - 333H**IBD-FS****'Fire Seal' Fire and Leakage Rated Damper**

Roll formed Blades and Frame

Universal Mounting Sleeve and Angles

334 - 349H

Fire and Smoke Rated Motorised Steel Damper – HFS

Model: HFS

The Holyoake HFS damper is a fire, fire-smoke, smoke, and air control (smoke exhaust) rated motorised steel damper, designed to impede the spread of fire through ducted air systems whilst maintaining barrier integrity. A self-contained opposed blade damper, and externally operable by a spring return actuator, the HFS damper offers supreme fire and smoke leakage performance due to the uniquely patented sealing system.

Minimal airflow impedance was a primary consideration in the HFS damper's design to comply with Energy Efficiency requirements as per NCC Volume 1 - Section J in Australia, and NZBC - Clause H1 in New Zealand. Ease of installation was also a key consideration, with only minimal labour required, the HFS damper can be quickly and easily installed.

HFS Fire /Smoke Damper Rating

Tested in accordance with AS 1530.4:2014 and AS 1530.7:2007, integrity was maintained for more than four hours and smoke leakage below 56L/s/m². Leakage integrity rates are based on the European ISO Standard 10294-1 'S' Classification.

For the purposes of the Australian Construction Code and New Zealand Building Code, the damper has a FRL / FRR of -/240/- and is constructed to the requirements of AS 1668.1 and AS 1682.1.

Certification

- **CSIRO**

Fire Short Form Report No. FCO - 3495

in accordance with AS 1530.4:2014 - Section 11.

Certified for up to 240 minute fire rating with leakage integrity performance as low as 20L/s/m² @ >1100°C and 300Pa.

- **Warringtonfire**

Smoke Summary of Assessment No. SOA - 220327

in accordance with AS 1530.7:2007.

Leakage as low as 38 L/s/m² @ 200°C and 300Pa as per the performance requirements of AS 1682.1:2015 Table 4 & 5 for smoke and air dampers respectively.

(Available upon request).

Features

- Fire rated smoke damper.
- Fire leakage integrity rated to AS 1530.4:2014.
- Smoke leakage rated to AS 1530.7:2007.
- Tested as an air damper (smoke exhaust) as per the performance requirements in AS 1682.1:2015 Table 5.
- Available in sizes up to 1200 x 1200 mm for single sections.
- Multiple section damper sizes available up to 2400 x 2400 mm in two wide by two high configurations.
- Each damper section will be supplied with a factory fitted actuator complying with AS 1682.1:2015. Multiple section dampers with have up to four mounted actuators (two on each side).
- Multiple ducted connections are available in a multiple section damper configuration.
- Performance in vertical and horizontal applications, with airflow from either direction.

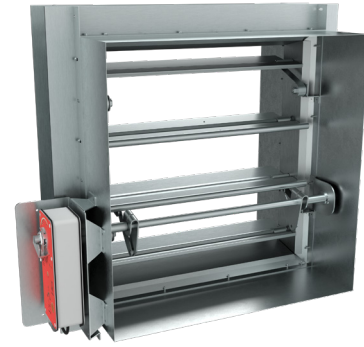

Installation

- Suitable for vertical and horizontal installations with airflow and fire/smoke from either direction in a wall and from below in a floor.
- Mounting sleeves are supplied raw-edged, with duct flanges available on request.
- Breakaway joints are required up to 150 mm from the wall or 250 mm from the wall on the actuated side.
- Dampers installed within the same construction element need to be separated by at least 200 mm and all dampers need to be installed 75 mm from an adjacent construction element.
- Actuators used to operate the damper must not exceed a travel time of 30 seconds in either direction.
- HFS fire and fire-smoke dampers must be installed within the fire barrier and as per Holyoake's installation instructions and details.
- HFS smoke (only) dampers may be installed up to 600 mm away from or within the smoke barrier and as per Holyoake's installation instructions and details.
- Dampers must not be installed with the blades vertical.

Configurations

- HFS fire damper activated by a fusible link and closed by constant force springs.
- HFS combination fire and smoke damper activated by a fusible link or smoke activation attachment (by others) - closed by constant force springs or, on smoke detection, spring return actuator.
- HFS smoke damper activated by a smoke activation attachment (by others) and closed by spring return actuator.
- HFS air control (smoke exhaust) damper operated by a spring return actuator, suitable for smoke dampers that require a high temperature rating.

Construction

Frame and Blades:	1.15 mm G250 Z275 galvanised steel
Sleeve Material:	0.75 mm G250 Z275 galvanised steel
Mounting Angles:	2 mm G250 Z275 galvanised steel angle (four on each side of the penetration, eight total), with 3 mm thick high temperature seal pre-installed on fixed angles
Damper Seals:	301 and 304 stainless steel
Components:	G250 Z275 galvanised steel
Finish:	Mill
Minimum Nominal Size:	200 (wide) x 200 mm (high)
Maximum Nominal Size:	1200 (wide) x 1200 mm (high)
Maximum Nominal Size:	2400 (wide) x 2400 mm (high)
	(multiple section)

Installation Guide

The following installation guide with associated method and diagrams shown on the following pages are presented as the method by which Holyoake HFS fire and smoke rated dampers must be installed.

Fire and smoke dampers are required to be installed as per the manufacturer's instructions with general comments being provided by AS 1682.1:2015 and AS 1682.2:2015.

Dampers must be installed as tested or assessed.

1. The casing shall completely penetrate the separating element and be retained:
 - (a) On both sides by four mounting angles such that it can expand in a fire without distorting the blades in a closed position; or
 - (b) On the accessible side only by four mounting angles. These will be factory fitted to the fire damper and will permit the damper to be fixed to the fire barrier through oversized holes and penny washers (on-site alteration). Fixings should be finger tight (to allow movement for thermal expansion) but locked, i.e. with double nut (lock nut); or
 - (c) On the top side of the horizontal element when the underside is not accessible or is formed and does not provide a level surface.
2. The overall clearance (total expansion gap) in both height and width should be 22 mm for dampers up to 1200 mm, and 30 mm for dampers up to 2400 mm. Never should the total expansion gap exceed 50% of the damper angle's face width that rests against the separating element.
3. The damper shall be installed so that the airflow does not impede its closure. Consideration also should be taken for appropriate air velocities so that they do not exceed 10m/s while also limiting the pressure drop to be under 15Pa.
4. The pressure differential across the closed damper should not exceed 750Pa.
5. The method of attaching ductwork to the damper must be such that any deformation or collapse of the ductwork in a fire does not dislodge the damper or affect its performance. This is best achieved using slip joints which allow damaged ductwork to fall away. Refer to "Breakaway Joints" within AS 1682 parts 1 and 2.
6. Holyoake dampers do not require packing between the sleeve and penetration.
7. Dampers are required to be installed with a 200 mm separation between dampers, and a 75 mm separation between the damper and an adjacent element of construction.
8. Access doors or removable pressed panels must be provided for duct entry to inspect the damper, confirm operation, and remove any obstructions.
9. When installed and closed, the blade and pivots must be fully contained within the penetrated element and within the casing. Only exception is when installed solely as a smoke damper: the HFS smoke damper is permitted to be installed up to 600mm away from the smoke barrier.
10. Holyoake dampers must be sleeve mounted using the factory fitted sleeves and angles.
11. Holyoake dampers must be installed with no obstructions and in accordance with the "this way up" arrow. Airflow may be from either direction.
12. Holyoake dampers include a completed installer's label compliant with AS 1682.2 - 2015.

HFS Damper Dimensions

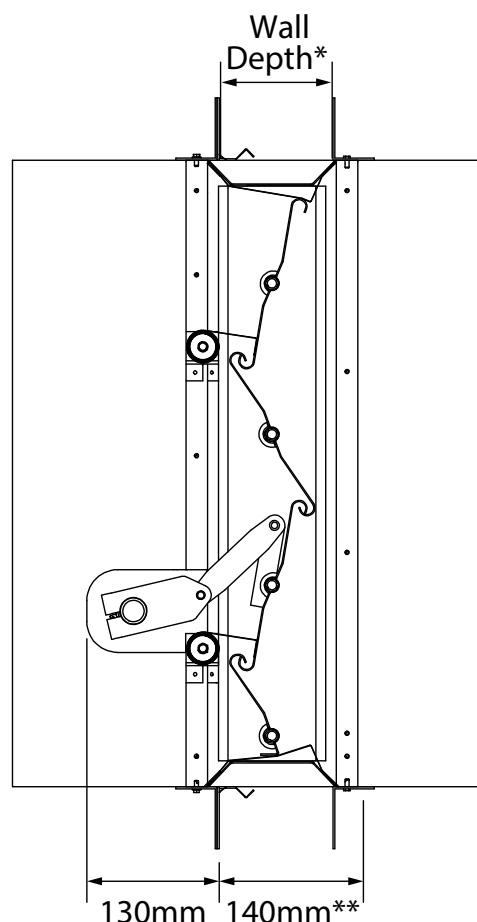

* Maximum wall/floor depth with standard 450mm sleeve: 170mm. (for deeper walls and floors specify depth when ordering)

** Depth of open blades into the wall/floor penetration.

Notes

1. The damper and fixed retaining angles are factory fitted to the sleeve. The loose angles must be fixed to the factory fitted sleeve (no extensions) and through every second pre-punched hole (175mm spacing) with 10g x 16mm long hex head self-drilling screws - available to purchase.
2. Retaining angles are a minimum thickness of 2 mm as tested (AS 1530.4:2014). They are mandatory on all four sides of at least one face. Contact your local Holyoake branch for more details..
3. Materials for the damper, sleeve, and retaining angles comply with AS 1682.1:2015, which specifies using galvanised steel with a coating class of not less than Z275.
4. Fire and smoke damper certifications are consistently being updated. Contact your local Holyoake branch for updated installation details and compliant wall and floor constructions.

Vertical Damper Installation

Masonry & Concrete construction

- For applications up to 120 minutes: wall thickness must be a minimum of 110 mm.
- For applications up to 240 minutes: wall thickness must be a minimum of 150 mm.

Speedpanel construction

- For applications up to 120 minutes: wall system must be constructed from 78mm Speedpanel.

Plasterboard construction

- For applications up to 60 minutes: overall wall thickness must be a minimum of 90 mm with linings of 1 x 16 mm fire grade plasterboard.
- For applications up to 90 minutes: overall wall thickness must be a minimum of 96 mm with fire rated plasterboard linings of 2 x 16 mm in New Zealand or 2 x 13mm in Australia.
- For applications up to 120 minutes: overall wall thickness must be a minimum of 116 mm with fire rated plasterboard linings of 2 x 19 mm in New Zealand or 2 x 16mm in Australia.
- Wall systems may be comprised of either timber or steel framing

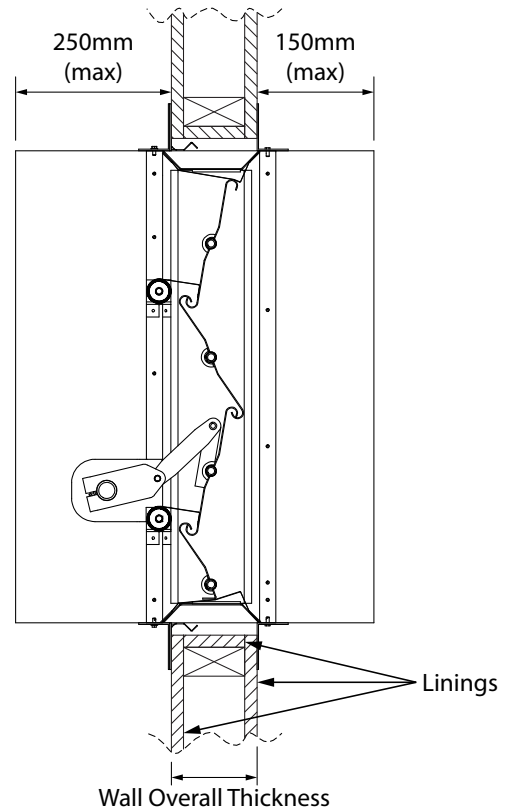
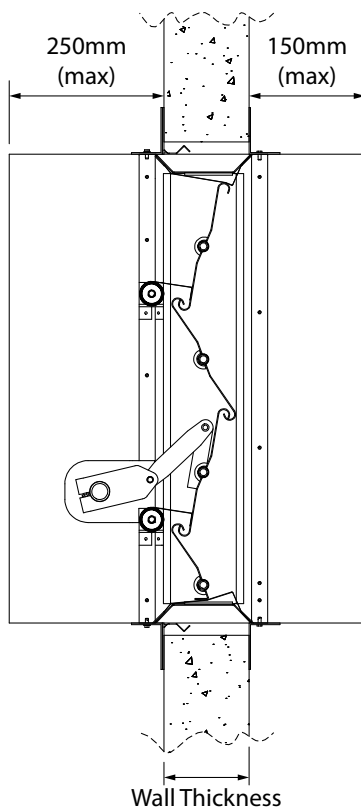

Notes

- The damper must be installed in accordance with the “this way up” arrow. Airflow can be from either direction.
- Breakaway joints must comply with the requirements of AS 1682.2 Clause 6.1(a) & (b). The damper sleeve must not extend beyond the face of the wall by more than 150 mm on either side, unless an actuator is fitted allowing the sleeve to extend up to 250 mm on the actuator side only.
- The overall clearance (total expansion gap) between the damper and penetration must be 22 mm, and must not exceed half the width of the mounting angle.
- Supporting construction must be tested or assessed to achieve the FRL/FRR of the damper when an aperture is made.
- These details are provided as guides for the compliant installation of the HFS damper in a vertical element as per CSIRO Short Form Report FCO-3495.
- For detailed installation instructions refer to the Installation Guide on page 2.

HFS – Fire and Smoke Rated Motorised Steel Damper

Vertical Damper Installation

Duct to Grille

- Louvers and grilles can be installed flush with the wall system, provided the wall depth is suitable.

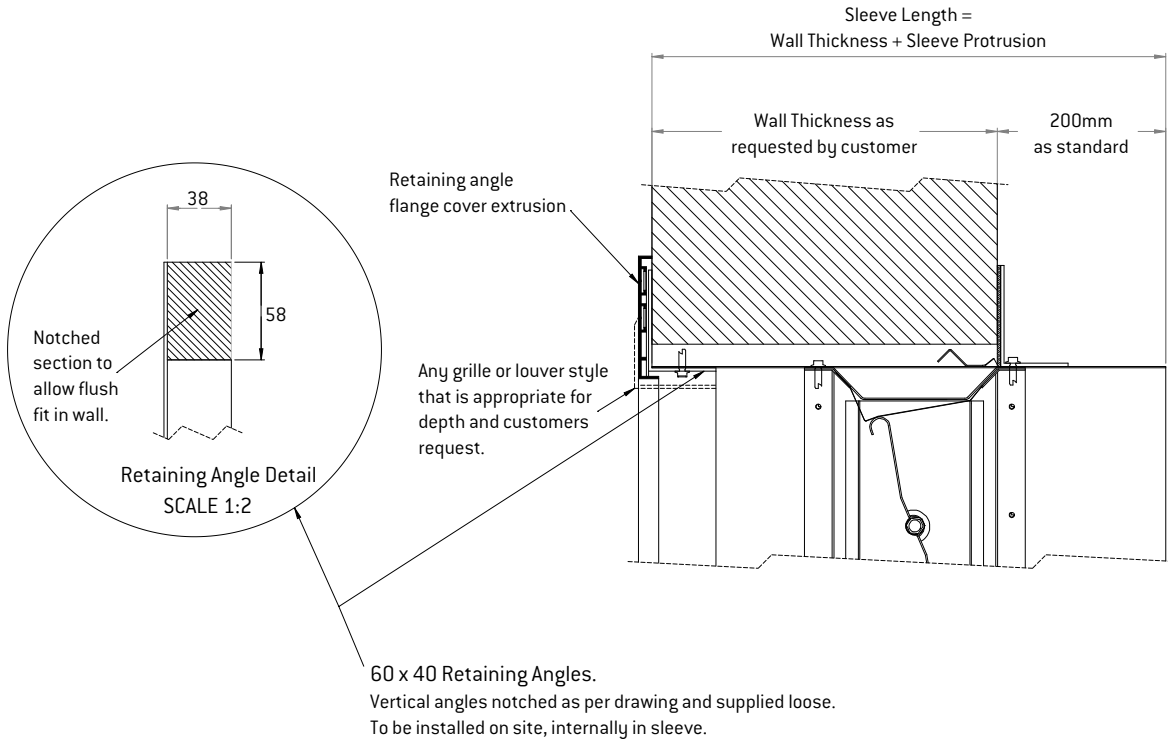

Hebel construction

- For applications up to 60 minutes: 75 mm Hebel system must be fitted with a packer around the aperture of 1 x 16 mm fire grade plasterboard.
- For applications up to 90 minutes: 75 mm Hebel system must be fitted with a packer around the aperture of 2 x 16 mm fire grade plasterboard.
- For applications up to 120 minutes: 75 mm Hebel system must be fitted with a packer around the aperture of 1 x 75 mm AAC (Hebel).

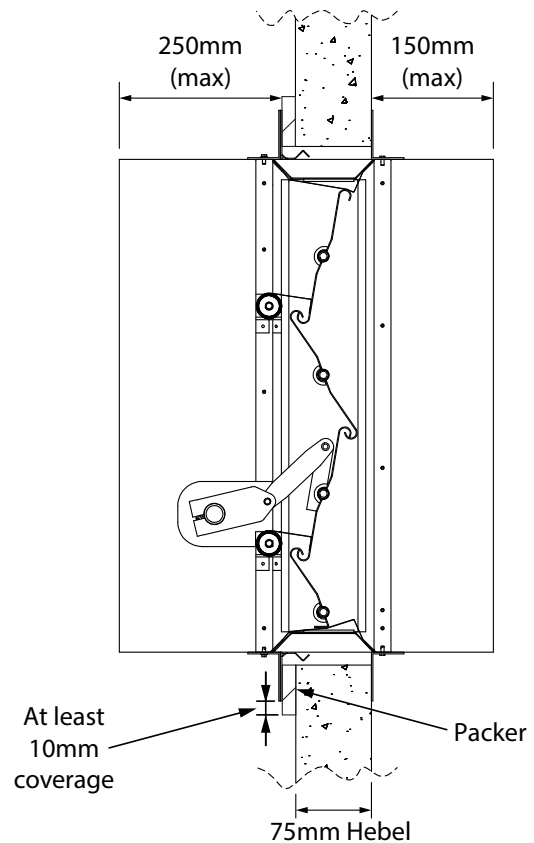

Horizontal Damper Installation

Masonry & Concrete construction

- For applications up to 120 minutes: slab thickness must be a minimum of 120 mm.
- For applications up to 240 minutes: slab thickness must be a minimum of 150 mm.

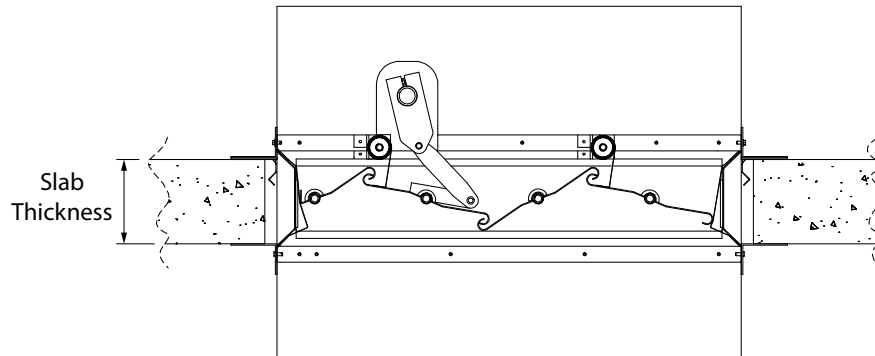

Timber construction

- For applications up to 60 minutes: joist thickness must be a minimum of 150 mm with linings of 2 x 13 mm fire grade plasterboard.
- For applications up to 90 minutes: joist thickness must be a minimum of 150 mm with linings of 2 x 16 mm fire grade plasterboard.
- For applications up to 120 minutes: joist thickness must be a minimum of 150 mm with linings of 2 x 19 mm fire grade plasterboard in New Zealand and 3 x 16 mm fire grade plasterboard in Australia.
- Timber floor dampers can only be installed as single sections (maximum size: 1200 x 1200mm).
- Lining on the top of the floor construction can be reduced by one layer but internal and underside layer requirements are as specified above.

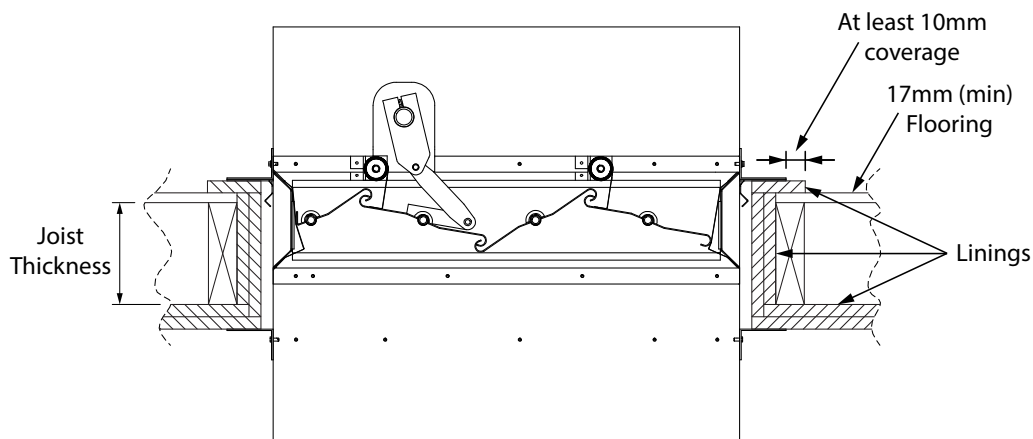

Notes

- The factory fitted angles must be located on the top of the penetration in accordance with the “this way up” arrow.
- Insulated ductwork mounted above a fire damper should be installed so it will not breakaway or collapse in a fire. This will prevent ignition of adjacent materials to the extent required by AS 1682.2 Appendix A(h).
- The overall clearance (total expansion gap) between the damper and penetration must be 22 mm, and must not exceed half the width of the mounting angle.
- Supporting construction must be tested or assessed to achieve the FRL/FRR of the damper when an aperture is made.
- These details are provided as guides for the compliant installation of the HFS damper in a horizontal element as per CSIRO Short Form Report FCO-3495.

HFS – Fire and Smoke Rated Motorised Steel Damper

Multiple Section Installation

Multiple section dampers are installed as per single section dampers, including the separating element details.

Dampers may be arranged in a modular arrangement up to maximum overall nominal dimension of 2400 x 2400 mm, incorporating structural mullions between sections.

Dampers installed within the same construction element must be separated by 200 mm. This causes problems when multiple ducts run within 200 mm, or through one penetration. Multiple adjacent ducts can be incorporated into one damper by allowing duct runs to be installed at least 65 mm away and removing the 200 mm separation requirement.

Modular dampers constructed for use with adjacent ducts can vary in width and height as appropriate, and are certified for installation in wall and floor systems.

Model: HFS - Single Ducted Damper

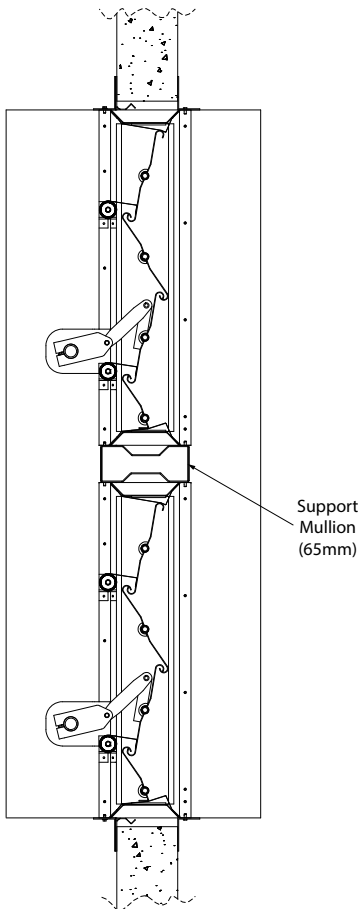

Model: HFS - Multiple Ducted Damper

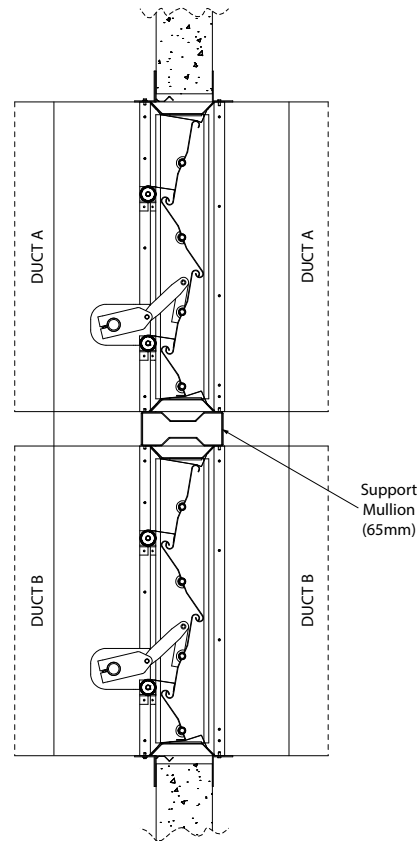

Notes

- The damper must be installed in accordance with the “this way up” arrow. Airflow can be from either direction.
- Breakaway joints must comply with the requirements of AS 1682.2 Clause 6.1(a) & (b). The dampers sleeve must not extend beyond the face of the wall by more than 150 mm on either side, unless an actuator is fitted allowing the sleeve to extend up to 250 mm on the actuator side only.
- Insulated ductwork mounted above a fire damper should be installed so it will not breakaway or collapse in a fire. This will prevent ignition of adjacent materials to the extent required by AS 1682.2 Appendix A(h).
- The overall clearance (total expansion gap) between the damper and penetration must be 30 mm, and must not exceed half the width of the mounting angle.
- Supporting construction must be tested or assessed to achieve the FRL/FRR of the damper when an aperture is made.
- These details are provided as guides for the compliant installation of the HFS damper in a vertical or horizontal element as per CSIRO Short Form Report FCO-3495.

Fire and Smoke Rated Motorised Steel Damper – HFS

Model: HFS

Height (mm)	AREA FACTOR TABLE										
	Width (mm)										
	200	300	400	500	600	700	800	900	1000	1100	1200
240	51.59	30.03	21.18	16.36	13.33	11.24	9.72	8.56	7.65	6.91	6.31
386	26.23	15.27	10.77	8.32	6.78	5.72	4.94	4.35	3.89	3.52	3.21
532	17.95	10.45	7.37	5.69	4.64	3.91	3.38	2.98	2.66	2.41	2.20
678	13.43	7.82	5.52	4.26	3.47	2.93	2.53	2.23	1.99	1.80	1.64
824	10.87	6.33	4.46	3.45	2.81	2.37	2.05	1.80	1.61	1.46	1.33
970	9.03	5.26	3.71	2.86	2.33	1.97	1.70	1.50	1.34	1.21	1.10
1116	7.79	4.54	3.20	2.47	2.01	1.70	1.47	1.29	1.16	1.04	0.95
1200	7.16	4.17	2.94	2.27	1.85	1.56	1.35	1.19	1.06	0.96	0.88

[All dimensions include 6 mm clearance total between outside of damper frame and inside of duct].

For pressure drop through an open HFS fire and smoke rated damper, use the following procedure:

1. Enter duct width and height into the table above to find the Area Factor.
2. Determine the Conversion Velocity (CV) by multiplying the Area Factor by airflow in m³/s [CV = Area Factor x m³/s].
3. Enter the pressure drop chart below with the Area Factor (Step 1) and establish the intersection with the Conversion Velocity line (Step 2); read the resulting pressure drop off the left hand side of the chart.

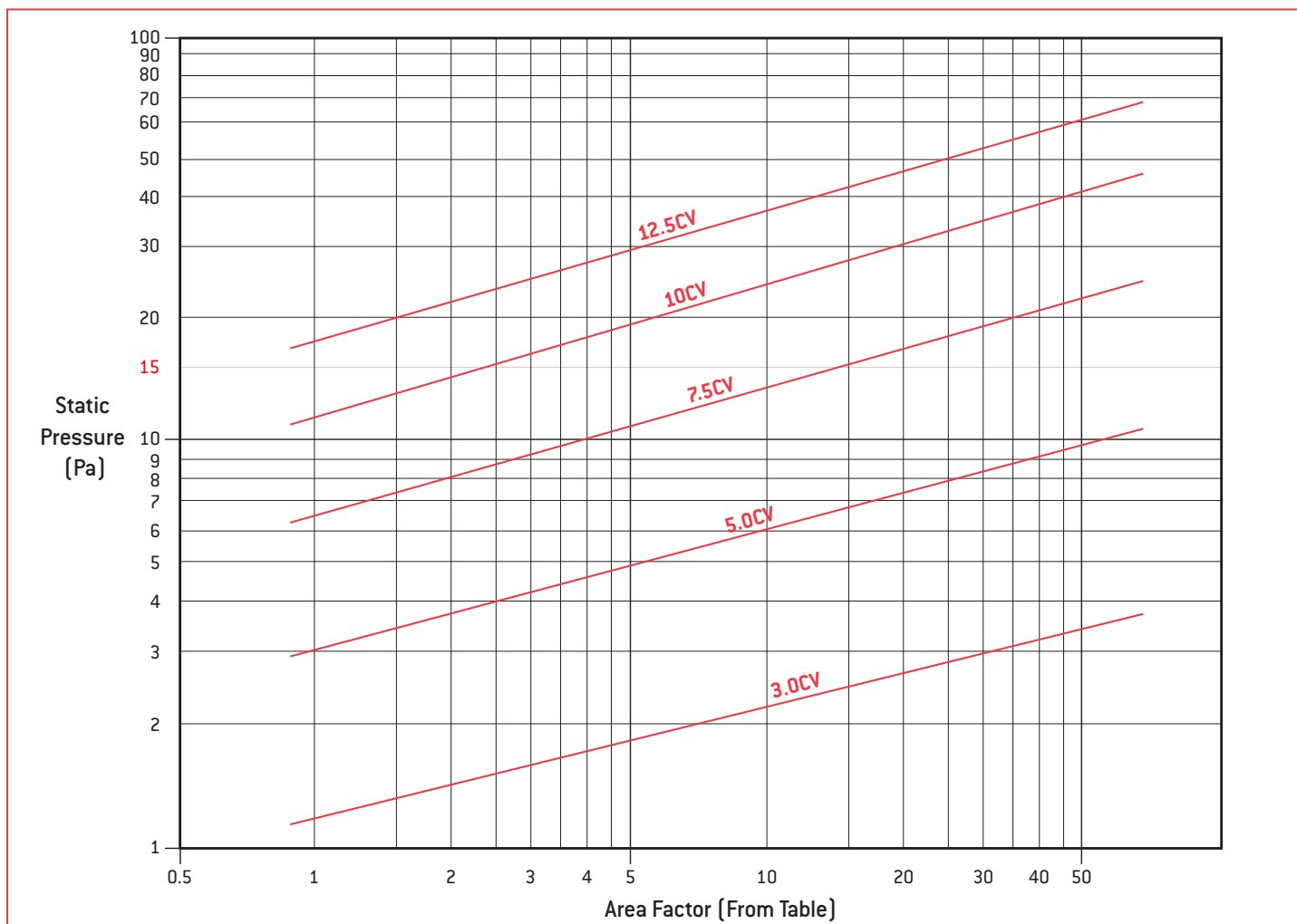

Notes

1. Static Pressure and Conversion Velocities are correct for 1.2 kg/m³ air density.
2. Ratings are based on dampers installed in accordance with details in this catalogue, with ductwork upstream and downstream.
3. For dampers between sizes, use the data figures from the smaller sized damper.
4. Pressure drop data has been obtained through CFD analysis.

HFS – Fire and Smoke Rated Motorised Steel Damper

Product Ordering Key and Suggested Specifications

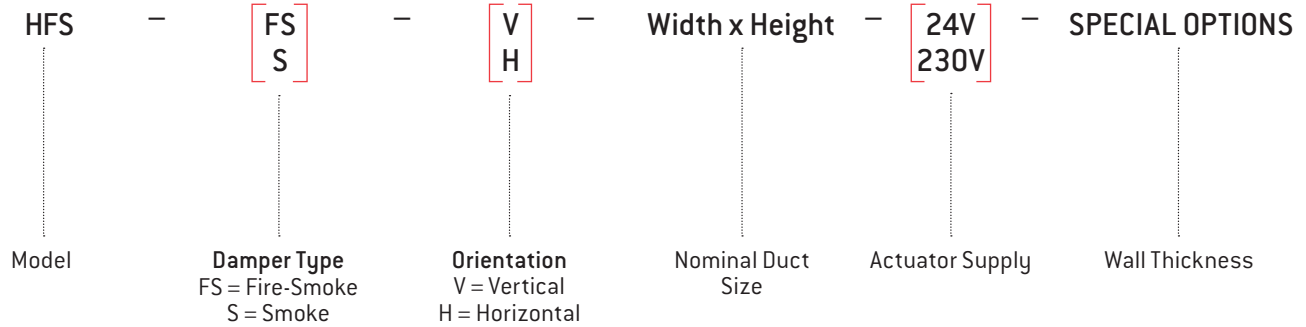

Holyoake HFS fire and smoke dampers shall be of single or multiple opposed blade type construction, with stainless steel seals; conforming to AS 1530.4:2014 Section 11 and AS 1530.7:2007 leakage requirements with up to a 4 hour fire rating.

Fire and smoke leakage rated dampers shall be for vertical and horizontal mounting and close by either a 71°C fusible link in fire and fire-smoke applications with constant force springs or smoke activation (by others) with a spring return actuator that complies with AS 1682.1 Section 2.5.4.

External access to the actuator guarantees a simple and straightforward maintenance program for testing the operation of the damper without needing to access the blades or remove fusible links in order to then test and reset the blades. Inspection and testing of all dampers should be completed as stipulated by AS 1851 Section 13.

Fire and smoke leakage rated dampers shall be installed in walls and floors utilising factory fitted angles fitted to the damper sleeve as shown in the manufacturer's instructions and drawings within this manual.

HFS fire and fire-smoke dampers comprise the same components and shall be the Holyoake Series HFS-FS and shall be manufactured and supplied by Price Holyoake.

HFS smoke and air control (smoke exhaust) dampers comprise the same components and shall be the Holyoake Series HFS-S and shall be manufactured and supplied by Price Holyoake.

MODEL: LR

FIRE / SMOKE (EXHAUST) / FIRE AND SMOKE / BALANCING DAMPER

The Holyoake Series LR fire / combination fire and smoke dampers are designed to impede the spread of fire and smoke between building compartments, whilst maintaining the barriers integrity. The low leakage damper blade assembly, with blade tip sealing ring, forms a solid barrier against flame, smoke, and hot gases. This leakage performance is guaranteed by our quality control process that we conduct on each damper.

LR 100 - LR 250 FIRE / SMOKE RATING:

Tested in accordance with AS 1530.4 - 2014 and AS 1530.7 - 2007, integrity was maintained for in excess of four hours and smoke leakage below 50l/s.

For the purposes of the Australian National Construction Code and New Zealand Building Code, the damper has a F.R.L./F.R.R. of -/240/- in a masonry wall / floor and -/120/- in a plasterboard wall, timber framed floor, and Hebel system.

LR 300 AND LR 350 FIRE / SMOKE RATING:

Tested in accordance with AS 1530.4 - 2014 and AS 1530.7 - 2007, integrity was maintained for in excess of 90 minutes and smoke leakage below 50l/s.

For the purposes of the Australian National Construction Code and New Zealand Building Code, the damper has a F.R.L./F.R.R. of -/90/- in a masonry wall / floor, plasterboard wall, timber framed floor, and Hebel system.

FEATURES

- Simple installation with flat head screwdriver utilising patented clamping system:
 - No sealant.
 - No fixings required.
- Minimal onsite labour.
- Smoke leakage rated to AS 1530.7 - 2007.
- Optional actuator and attachment (by others) required for smoke damper functionality.
- Available in seven diameters: 100, 125, 150, 200, 250, 300, and 350mm.
- Easy test and reset fusible link.
- Adjustable blade for airflow balancing.

NOTE: LR 100 utilises the LR 125 damper with 100-125 adaptor collars.

CONFIGURATIONS

- LR fire damper with brass fusible link.
- LR combination fire and smoke damper with spring return actuator and electro-thermal link.
- LR smoke (exhaust) damper with spring return actuator.
- LR balancing damper with either brass fusible link or actuator; applicable in combination with the other damper configurations.

CERTIFICATION

CSIRO

Fire Test Certificate No. COA 3316 in accordance with AS 1530.4 - 2014 : Section 11 (Ducted Damper Installations).

(LR 100 - LR 250 certified for 240 minute fire rating).

(LR 300 and LR 350 certified for 90 minute fire rating).

WARRINGTONFIRE

Smoke Leakage Test Certificate No. SFC 53556800.2 and SFC 2100015.1 in accordance with AS 1530.7 - 2007.

Leakage below 50l/s @ 200°C in accordance with AS 1682.1-2015.

The LR damper can be supplied as either a fire, smoke (exhaust), or fire and smoke damper with the ability to be set to balance the airflow. It is quick and easy to install, maintain, and test. The unit comes complete with mounting flanges, jubilee clip, and the patented heat shield is supplied for plasterboard applications.

Fire protection is provided by a fusible link (manual or electro-thermal) and damper blade that seals the duct shut in the event of a fire to maintain minimum leakage as required by the test standard.

KEY INSTALLATION DETAILS

- No internal linings are required for the majority of plasterboard penetrations.
- Standard sleeve configuration suits barriers up to 190mm.
- Extended sleeve configuration suits barriers up to 295mm.
- Assessed to be installed 35mm from the damper to the adjacent element and 70mm between two LR dampers.
- Actuators available as either 24V or 240V.
- Penetration sizing (cut-out template on packaging):

Damper Size (Ø)	Penetration (mm)
LR100/125	130 - 138
LR 150	155 - 163
LR 200	205 - 213
LR 250	255 - 263
LR 300	305 - 313
LR 350	355 - 363

NOTE: See pages four - seven for detailed installation guides, including specific instructions for all plasterboard installations.

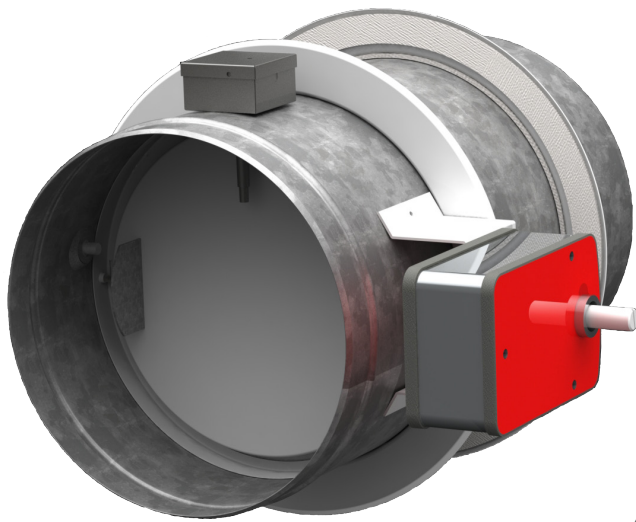

LR Fire and Smoke Damper

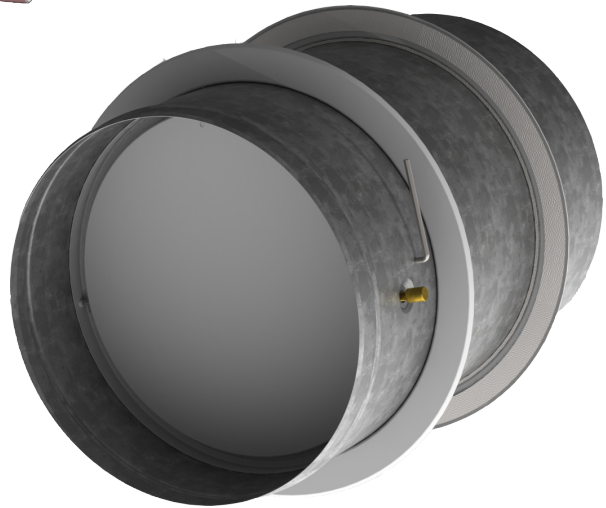

LR Fire Damper

DIMENSIONS:

Standard Configuration (suits fire barriers up to 190mm)

Extended Sleeve Configuration (suits fire barriers up to 295mm)

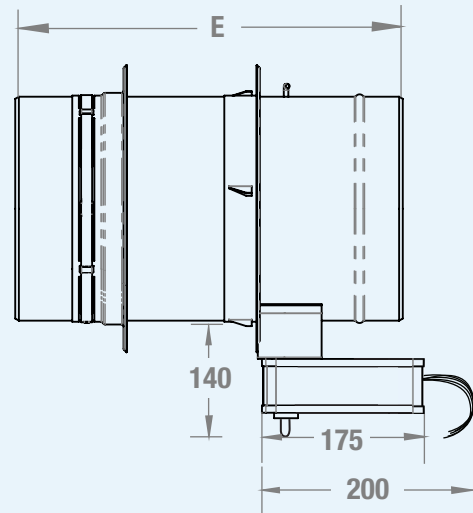
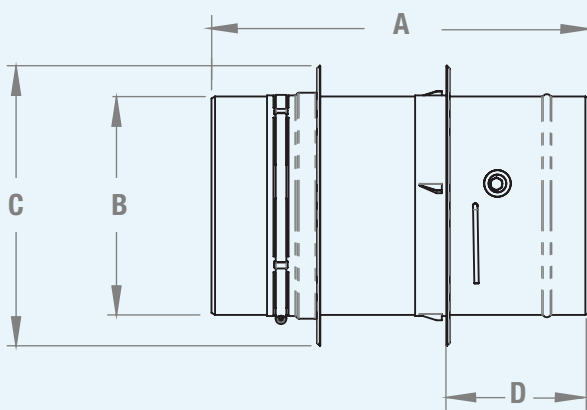

	LR 100 / LR 125	LR 150	LR 200	LR 250	LR 300	LR 350
A	425	425	425	425	-	-
B	96 / 121	146	196	246	296	346
C	190	215	265	315	365	415
D	150	150	150	150	150	150
E	530	530	530	530	530	530

NOTE: All dimensions are in mm

MASONRY, DRYWALL, AND TIMBER FRAMED FLOOR INSTALLATIONS

INSTALLATION INSTRUCTIONS

1. Cut penetrations as per table below. For a masonry and drywall installation use the left column and for a timber framed floor refer to special instructions below.
2. Insert Holyoake flexible heat shield into penetration (plasterboard applications only).
3. Remove loose flange from damper.
4. Insert damper through penetration until fixed flange is firmly seated on the fire barrier.
5. Slide loose flange (with seal side facing wall) onto damper and tighten jubilee clip with screwdriver.
6. Using damper handle and fusible link, test damper operation and then set blade to required position.

Damper Size (Ø)	Standard Penetration (mm)	Timber Flooring Penetration* (mm)
LR100/125	130 - 138	160 - 180
LR 150	155 - 163	185 - 205
LR 200	205 - 213	235 - 255
LR 250	255 - 263	285 - 305
LR 300	305 - 313	335 - 355
LR 350	355 - 363	385 - 405

*Penetration size for timber framed floors 17mm min. flooring

SPECIAL PENETRATION SIZING FOR TIMBER FRAMED FLOOR INSTALLATION

The penetration through a timber framed floor requires two uniquely sized holes. These dimensions can be found in the table above and are explained below:

1. The plasterboard underside is to be cut as per the dimensions in the left column (Standard Penetration) of the table.
2. The flooring on the top side of the penetration, is to be cut to the larger diameter sizing in the right column (Timber Flooring Penetration) of the table. This is to incorporate the flexible heat shield.
3. The inner diameter of the separator is to be sized as per the plasterboard underside (left column - Standard Penetration - of table) and must have at least 10mm of coverage as detailed in the installation on the right.

DRYWALL INSTALLATION - 60 MINUTE DETAIL

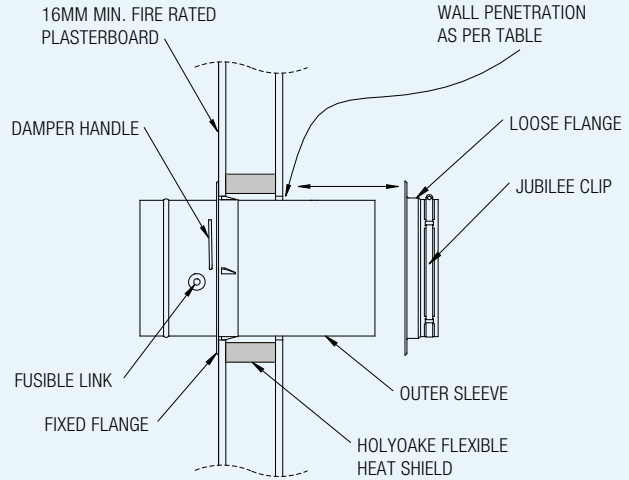

TIMBER FRAMED FLOOR INSTALLATION** - 60 MINUTE DETAIL

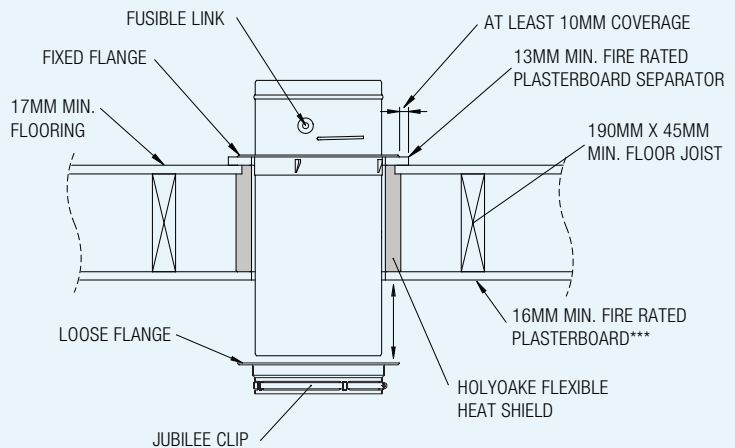

**Ensure any connecting ductwork is self-supporting

***Two Layers of 13mm min. fire rated plasterboard in Australia

SPECIAL INSTALLATION OPTIONS

1. The LR damper is able to be installed such that the sleeve is separated from an adjacent construction element by a minimum distance of 35mm (as shown on the right).
2. Multiple LR dampers can be positioned with their sleeves separated by a minimum distance of 70mm.

NOTE: These options are applicable to both vertical and horizontal installations.

DRYWALL AND TIMBER FRAMED FLOOR LINING INSTALLATION REQUIREMENTS

To determine the installation requirement of the LR damper use the following procedure:

1. Enter the wall or floor FRL/FRR that the damper will be fitted through in the table below.
2. Find the corresponding minimum distance(s) 'X' (depicted below in figure 1) between the dampers heat shield and the surrounding joists/ studs and noggings.
3. Use these two values to establish the required installation figure found below.



LR DAMPER
PRODUCT INFORMATION AND
INSTALLATION GUIDE

INSTALLATION ADJACENT TO CONSTRUCTION ELEMENT

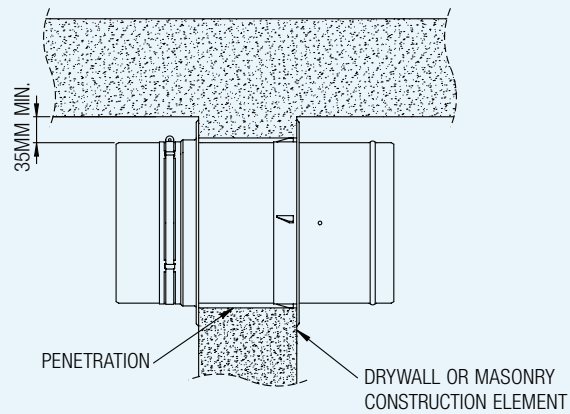

EXAMPLE: An LR 250 damper is to be placed in a timber framed floor with an FRL/FRR of 90/90/90, the dampers heat shield will be located 100mm away from one floor joist and over 145mm from the other joist and noggings.

1. From the table locate all floors with an FRL/FRR of 90/90/90.
2. Check the floors corresponding minimum distances (0mm and 145mm) against the actual distances (100mm and >145mm).
3. Figure 2 is therefore the obligatory installation, which requires one 16mm fire rated plasterboard lining on the joist located 100mm away from the heat shield.*

*Note that the remaining joist and noggings conform with figure 1 and so do not require an additional fire rated plasterboard lining.

FRL/FRR ¹			Corresponding Distance and Figures	
LR 100 - LR 250	LR 300 & LR 350	Wall or Floor	Minimum Distance (Xmm)	Installation Figure
-/60/-	-/60/-	-/60/60 or 60/60/60	0	1
-/90/-	-/90/-	-/90/90 or 90/90/90	0	2 ²
		-/90/90 ³	30	1
-/120/-	-	-/90/90 or 90/90/90	145	1
	-/90/-	-/120/120 or 120/120/120	0	2 ⁴
	-	-/120/120 ⁵	145	1

¹Tested in accordance with AS 1530.4:2014

³Wall constructions only

⁵Steel framing walls only

²One layer of 16mm fire rated plasterboard lining

⁴Two layers of 16mm fire rated plasterboard lining

ALTERNATIVE PENETRATION PLACEMENT DETAIL FOR WALLS AND FLOORS

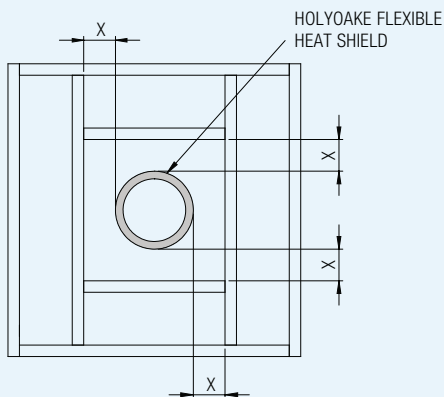

FIGURE 1: NO ADDITIONAL LINING REQUIRED

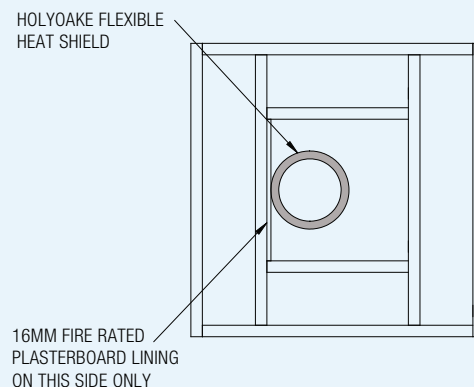

FIGURE 2: ADDITIONAL LINING REQUIRED WITHIN THIS COMPARTMENT ONLY

LR FIRE DAMPER INSTALLATION FLOWCHART

PENETRATION PREPARATION

To ensure the compliant installation of the LR fire damper, please follow the flowchart and steps below based on your specific job. Note that this preparation is only relevant for fire dampers and some penetrations will require additional lining (see chart below).

- STEP 1:** Begin with the fire barrier (separating element) the LR damper is being installed into.
- STEP 2:** Select the relevant separating elements required F.R.L./F.R.R.
- STEP 3:** Measure the anticipated distance from the heat shield to the nearest joist/stud or nogging.
- STEP 4:** Compare this value to the minimum distance allowed to a joist/stud or nogging.
- STEP 5:** Continue down the path to get the required number of 16mm fire rated plasterboard layers.
- STEP 6:** Attach the specified layers of fire rated plasterboard to that joist/stud or nogging along its entire length, in that cavity only. If the number of layers is not specified, no lining is required.
- STEP 7:** Repeat steps three to seven for all joists/studs and noggings in the penetrations cavity.
- STEP 8:** Proceed to the LR Installation Guide on the next page.

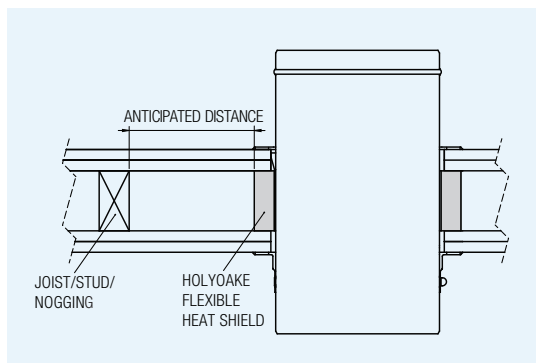
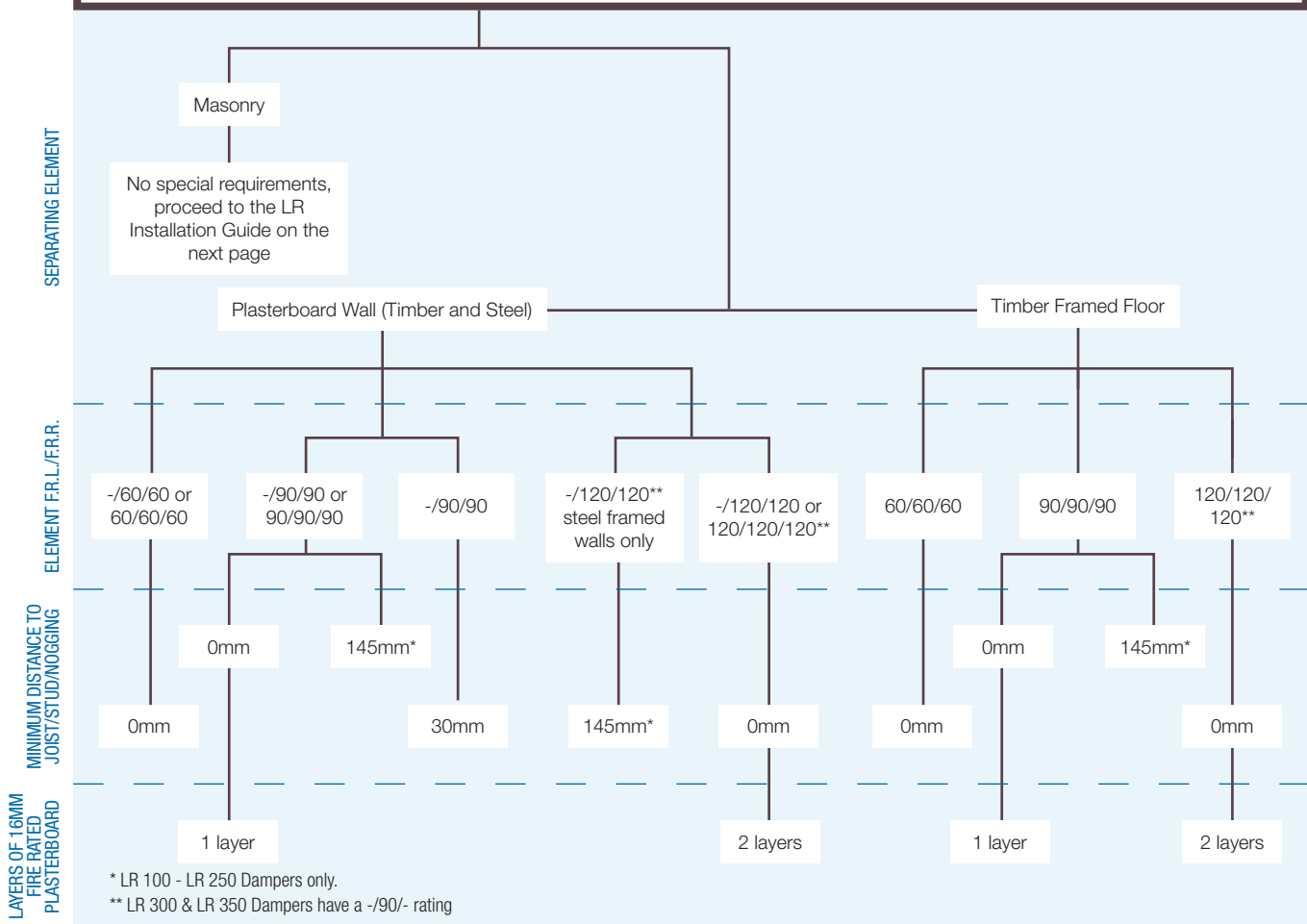

EXAMPLE: An LR 250 damper is to be placed in a plasterboard wall with an F.R.L./F.R.R. of 90/90/90, the dampers heat shield will be located 100mm away from one stud and over 145mm from the other stud and noggings. Using the flowchart, move down to 'Plasterboard Wall', locate all walls with an F.R.L./F.R.R. of 90/90/90, and check the wall's corresponding minimum distances (0mm and 145mm) against the anticipated distances (100mm and >145mm). This means the stud located 100mm away from the heat shield is classified under '0mm' and will require one layer of 16mm fire rated plasterboard. The other stud and noggings are classified under '145mm' and require no additional linings.

LR FIRE DAMPER INSTALLATION GUIDE

INSTALLATION STEPS

STEP 1. Cut penetration(s) as per Table 1 below.

STEP 2. Compress Holyoake flexible heat shield and insert into penetration (plasterboard applications only). Expand heat shield once inserted.

STEP 3. Remove loose flange from damper. Insert damper into penetration with fixed flange sitting against fire barrier.

STEP 4. Slide loose flange (high temperature seal facing wall) onto the damper and tighten jubilee clip with screwdriver.

STEP 5. Using damper handle and fusible link, test damper operation and then set blade to required position.

Table 1: Penetration Sizing

Damper Size (Ø)	Penetration (mm)	Flooring Penetration (mm)
LR100/125	130 - 138	160 - 180
LR 150	155 - 163	185 - 205
LR 200	205 - 213	235 - 255
LR 250	255 - 263	285 - 305
LR 300	305 - 313	335 - 355
LR 350	355 - 363	385 - 405

Blue arrows: indicate progression between steps of the installation.

Black arrows: illustrate directional movement required by the objects.

Timber Framed Floor [side view]

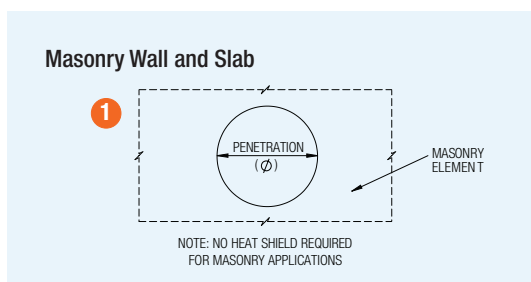
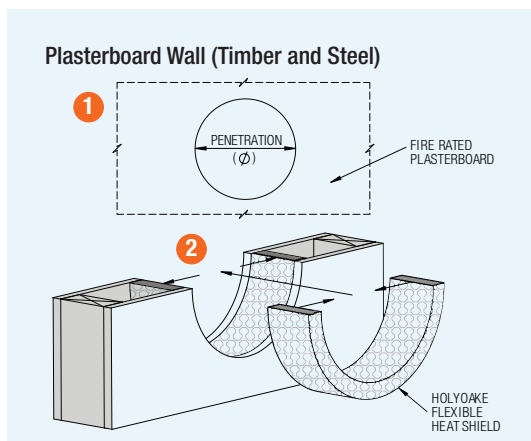
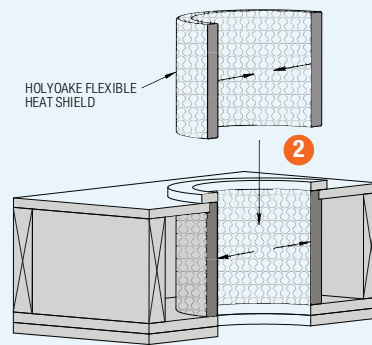
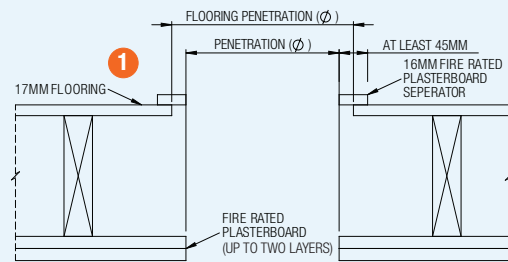

General Wall/Slab/Floor Installation

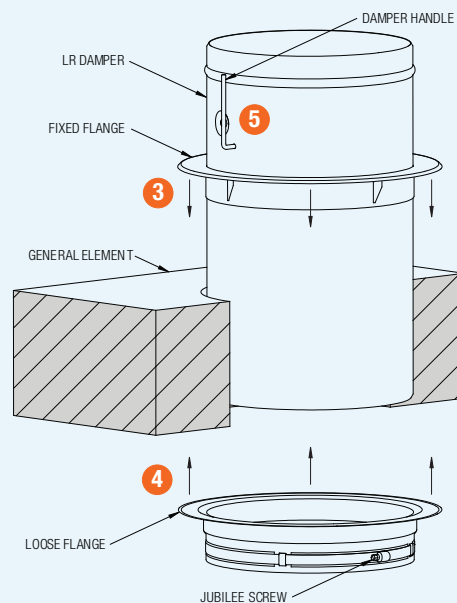

Performance Data

LR DAMPER PRESSURE DROP

Pressure Drop (Pa)						
FLOW RATE (L/S)	LR125	LR150	LR200	LR250	LR300	LR350
20	3.5	1.1	0.2	<0.1	<0.1	<0.1
40	13.7	4.5	0.9	0.1	<0.1	<0.1
41	15.0	4.9	1.0	0.1	0.1	0.1
60	32.0	10.7	2.1	0.3	0.2	0.2
71	45.2	15.0	2.9	0.8	0.2	0.2
80	57.5	19.0	3.7	1.1	0.3	0.2
100	90.5	29.8	5.9	1.8	0.6	0.3
120	129	42.6	8.5	2.6	0.9	0.4
140	176.3	58.6	11.6	3.6	1.2	0.5
160		76.2	15.0	4.8	1.7	0.7
180		96.7	18.9	6.1	2.3	1.0
200		118.0	23.3	7.4	2.9	1.2
240			34.0	11.0	4.2	1.7
273			46.1	15.0	5.5	2.3
280			60.6	15.1	5.8	2.4
320				19.6	7.6	3.2
360				24.8	9.7	4.1
400				30.8	11.9	5.1
440				37.2	14.5	6.2
446				39.4	15.0	6.6
480				44.2	17.4	7.4
520				51.9	20.4	9.0
560					23.8	10.3
600					27.3	11.7
640					31.0	13.6
653					32.4	15.0
680					35.1	15.8
720					39.3	17.8
760						19.9
800						22.0
840						24.3
880						26.7
920						29.1
960						31.7
1000						34.4

As per the requirements of Section J of Australia's NCC - Volume One, and New Zealand's Building Code - Energy Efficiency H1/MM3, the 15Pa pressure drop flow rate has been denoted in orange.

LR DAMPER PRODUCT GUIDE

Guide Product Weights			
LR Model	Weight (Kg)	LR Model	Weight (Kg)
LR100	1.6	LR250	2.8
LR125	1.4	LR300	3.8
LR150	1.65	LR350	4.7
LR200	2.25	LR Heatshield	0.35

Product Ordering Key & Suggested Specifications

LR	-	100	-	D	-	100	-	F	-	24V	-	EXT
		125		M		150		FS		230V		
		150				230		S				
		200										
		250										
		300										
		350										
Model		Size (diameter)		Structure <i>D = drywall*</i> <i>M = masonry</i>		Heat Shield (width) <i>drywall*</i> <i>only</i>		Damper Type <i>F = fire</i> <i>FS = fire-smoke</i> <i>S = smoke</i>		Actuator Supply <i>fire-smoke</i> <i>and smoke</i> <i>only</i>		Sleeve (length)** <i>standard</i> <i>(default)</i> <i>EXT = extended</i> <i>(optional)</i>

Holyoake LR 100 - LR 250 fire and smoke dampers have a four hour rating in a masonry wall/floor and a two hour rating in a steel/timber framed wall, timber framed floor, and Hebel system with a smoke leakage of less than 50l/s.

Holyoake LR 300 and LR 350 fire and smoke dampers have a 90 minute rating in a masonry wall/floor, steel/timber framed wall, timber framed floor, and Hebel system with a smoke leakage of less than 50l/s.

The damper is certified to AS 1530.4 - 2014 Section 11 (ducted damper installations), AS 1530.7 - 2007, as well as the requirements of the AS 1682 - 2015 series. The rating given by this certification applies to fires on both sides of a fire wall and the underside of a fire rated floor. Holyoake LR fire dampers contain a fusible link that releases and allows the damper to close upon reaching 71°C. An external lockable handle is included as standard that can be used to position the damper blade to provide volume control. Holyoake LR fire and smoke dampers contain an electro-thermal link that releases and allows the damper to close upon reaching 72°C. An actuator is included as standard that can be signalled to close by a building management system (BMS).

LR fire and smoke dampers should be annually tested as determined by AS 1851 - 2012 (Section 13): Routine service of fire protection systems and equipment.

LR fire and smoke dampers shall be Holyoake Series LR F, LR FS, or LR S and shall be manufactured and supplied by Price Holyoake.

* Drywall represents all plasterboard applications including timber framed floors.

** Standard sleeve length suits fire barriers up to 190mm; extended sleeve length suits fire barriers up to 295mm.

IBD-FS – Fire & Leakage Rated Dampers

Holyoake IBD – FS ‘Fire Seal’ Curtain-type fire and leakage rated dampers are designed to maintain the integrity of the fire resistance of a wall, in which a hole has been formed to permit the passage of air, ducted or otherwise, to enable an air distribution system to function; whilst minimising the impedance of fire and/or smoke and other toxic gases.

The arrangement of interlocking galvanised steel blades and stainless steel side seals, mounted in a galvanised steel guide channel frame, minimises space requirements and facilitates ease of installation in ductwork.

The IBD-FS fire and leakage rated damper has been tested in accordance with AS 1530.4 - 2014 and comfortably passed the leakage integrity rates of 11.6.2.1, which are based on the European ISO Standard 10294-1 ‘E’ Classification.

All Holyoake Series IBD - FS units carry up to a 4 HOUR rating, as determined by the following testing Authority.

Fire Rating:

Tested in accordance with Standard AS 1530.4 – 2014, integrity was maintained for in excess of 4 hours.

For the purposes of the Australian Construction Code and New Zealand Building Code they have a FRL/FRR of –/240/–.

Fire Assessment Short Form Report No. FC0-3356

IBD-FS Damper mounted in a:

- 110 and 140 mm thick masonry wall.
[Certified for 120 and 240 minute fire rating].
- 90, 96, and 103 mm thick steel or timber framed plasterboard wall.
[Certified for 60, 90, and 120 minute fire rating].
- 75 mm thick Hebel Wall system [with associated packer*].
[Certified for 60, 90, and 120 minute fire rating].
- 78 mm thick Speedpanel wall system.
[Certified for 120 minute fire rating].

Fire Assessment Regulatory Information Report No. FAS-190196

IBD-FS Damper mounted in a:

- 78 mm thick KOROK wall system**.
[Certified for 120 minute fire rating].

Fire Assessment Short Form Report No. FC0-3356 & FC0-3283

IBD-FS-H Damper mounted in a:

- 120 mm thick solid concrete slab.
[Certified for 240 minute fire rating].
- 190 mm thick timber framed floor.
[Certified for 120 minute fire rating].

[Short Form Reports and Certificates are available upon request].

* For packer requirements contact your local branch for a copy of FC0-3356.

** Limited damper sizes are available in KOROK wall systems.

Duct Connection:

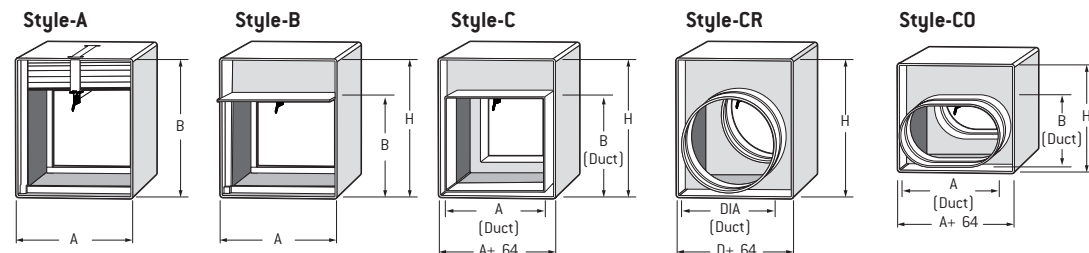

Mounting Sleeve omitted for clarity.

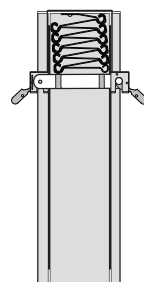

Single Section Maximum Dimensions

Duct Connection Style	A		B		C		CR	CO	
Maximum Dimensions Available	A	B	A	B	A	B	D	A	B
Vertical or Horizontal	1200	1200	1200	1046	1136	1014	1014	1136	1014

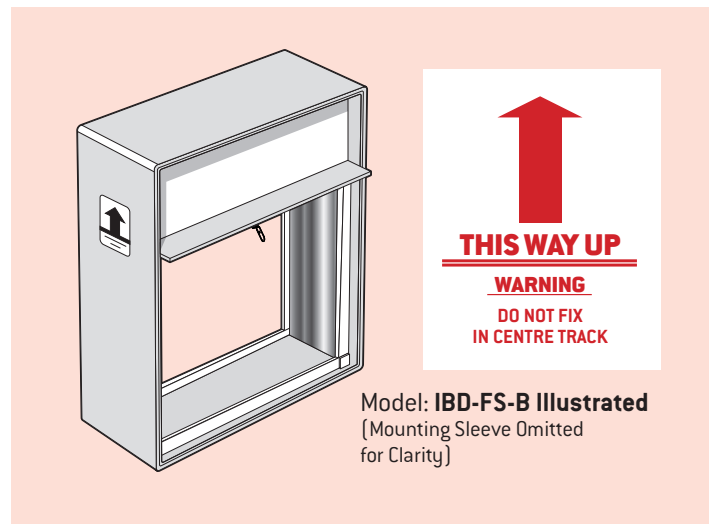

Standard Construction

Frame: 110 mm x 1.2 mm galvanised steel, roll formed guide channel.

Blades: 70 mm x 1.0 mm galvanised steel, roll formed Interlocking profile.

Seals: Blade End: stainless steel both sides.

Fusible Links: ‘Safe Test’ Test Latch Model IBD-TL fitted as standard with 71° C Fusible Link

See page 345H for more details.

[Other ratings available on request].

Please contact your local Holyoake branch.

Mounting: Vertical (wall) or Horizontal (floor).

Alternate Activation:

Electro Thermal Resettable Link. This device can be activated by smoke detectors of compatible design, (supply and fit by others). This can be linked to a BMS system to further speed up the initiation of a buildings fire dampers. For smoke damper applications see the HCD elevated temperature smoke damper range on pages 328 - 329H.

Mounting Sleeves: Series IBD-FS fire and leakage rated dampers must be installed in their factory fitted mounting sleeves.

Stainless Steel: Construction in Stainless Steel is available for the IBD-FS.

Assembly and Dimensional Information

(A & B Dimensions allow 6 mm clearance for mounting sleeve of nominated size)

Model: IBD-FS-A-V

Interlocking blade, vertical (wall) mounting damper, gravity operated, blade stack located **within air stream**.

Minimum size A 100 x B 160 mm.

Maximum size A 1200 x B 1200 mm. (Single Section).

Model: IBD-FS-B-V

Interlocking blade, vertical (wall) mounting damper, gravity operated, blade stack located **out of air stream**.

Minimum size A 100 x B 135 mm.

Maximum size A 1200 x B 1046 mm. (Single Section).

Model: IBD-FS-A-V (multiple)

The IBD-FS multiple is tested in accordance with AS1530.4-2014 and can be built up to a maximum of 3 units wide by 2 units high, giving a maximum damper size of 3600mm x 2400mm.

IBD-FS multiple section fire dampers are supplied with a 65mm wide support mullion between damper sections. This is to meet the pressure requirements of AS1530.4-2014.

• CSIRO

IBD-FS Modular Damper Fire Assessment Short Form Report No. FCO - 3356
(Certified for up to 240 minute fire rating).

Depending on the size of the fire damper and site access considerations the damper may be supplied in parts for on-site assembly. Contact your local Holyoake branch to discuss this option.

The damper assemblies do not provide structural support.

Alternatively, if individual damper sections are installed they must be separated by a minimum of 200 mm of structural support, of the same fire rating as the rest of the surrounding structure and in accordance with AS 1530.4-2014.

See multiple section damper installation details on page 343H for more information.

Model: IBD-FS-B-V (multiple)

See above for details, except Style 'B' assemblies where more than one unit high, would consist of "B" type units in the top row and "A" type in the bottom row (as illustrated).

Note: All IBD-FS dampers are fitted with Test Latch Links.

IBD-FS Duct Connection Style 'A'

(Single Section Damper Heights).

Dimension 'B'		Dimension 'X'
From	To	
160	- 183**	30
184	- 303**	42
304	- 423	54
424	- 543	66
544	- 663	78
664	- 783	90
784	- 903	102
904	- 1023	114
1024	- 1143	126
1144	- 1200	138

+ For testing purposes below 210 mm will require complete removal of link and blades dropped manually.

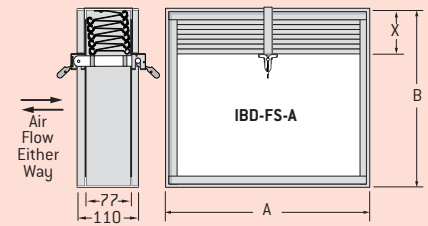

Mounting Sleeve omitted for clarity, refer to pages 339H - 344H.

IBD-FS Duct Connection Style 'B'

(Single Section Damper Heights).

Dimension 'B'		Dimension 'H' = B +
From	To	
135	- 143**	29
144	- 358**	54
359	- 573	79
574	- 788	104
789	- 1003	129
1004	- 1046	154

** For testing purposes below 160 mm will require complete removal of link and blades dropped manually.
* Restricted minimum height when fitted with Electro Thermal Resettable Links. (See separate table).

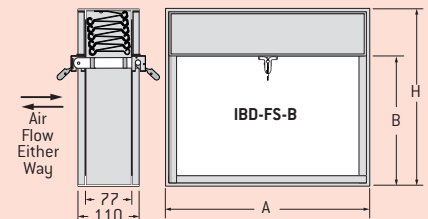

Mounting Sleeve omitted for clarity, refer to pages 339H - 344H.

Model: IBD-FS-A-V (Multiple)

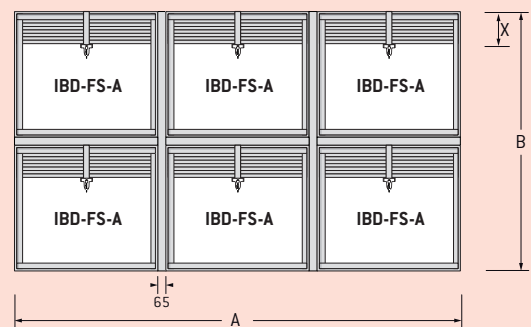

Model: IBD-FS-B-V (Multiple)

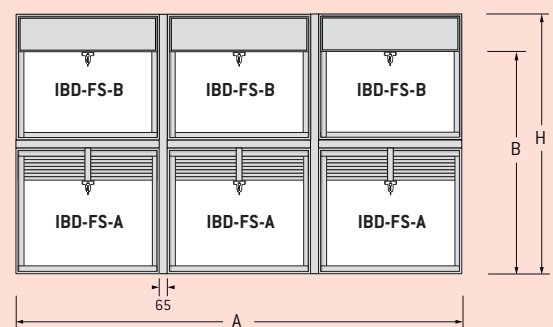

Mounting Sleeve omitted for clarity, refer to pages 339H - 344H.

Notes

1. In specifying a fire damper the width should always be stated first and the height second (* Maximum diameter 1014 mm).

2. Nominal dimensions are opening sizes and allow clearance for insertion into mounting sleeve:

6 mm Duct Connection A & B. 3 mm Duct Connection C, CR & CO.
Where this allowance is not required specify "exact size".

IBD-FS – Fire & Leakage Rated Dampers

Assembly and Dimensional Information

(A & B (Duct) Dimensions allow 3 mm clearance for duct of nominated size).

All IBD-FS-C styles, blade stacks located **out of air stream**.

Model: IBD-FS-C-V

Interlocking blade, vertical (wall) mounting damper, gravity operated, fitted with enclosure plates and square, or rectangular spigots to suit duct connections.

Minimum size A 100 (Duct) x B 140 (Duct).

Maximum size A 1136 (Duct) x B 1014 (Duct),
(Single Section).

Model: IBD-FS-CR-V

Interlocking blade, vertical (wall) mounting damper, gravity operated, fitted with enclosure plates and round spigots to suit duct connections.

Minimum size B 150 (Duct Diameter).

Maximum size B 1014 (Duct Diameter),
(Single Section).

Model: IBD-FS-CO-V

Interlocking blade, vertical (wall) mounting damper, gravity operated, fitted with enclosure plates and oval spigots to suit duct connections.

Minimum size A 100 (Duct) x B 150 (Duct).

Maximum size A 1136 (Duct) x B 1014 (Duct),
(Single Section).

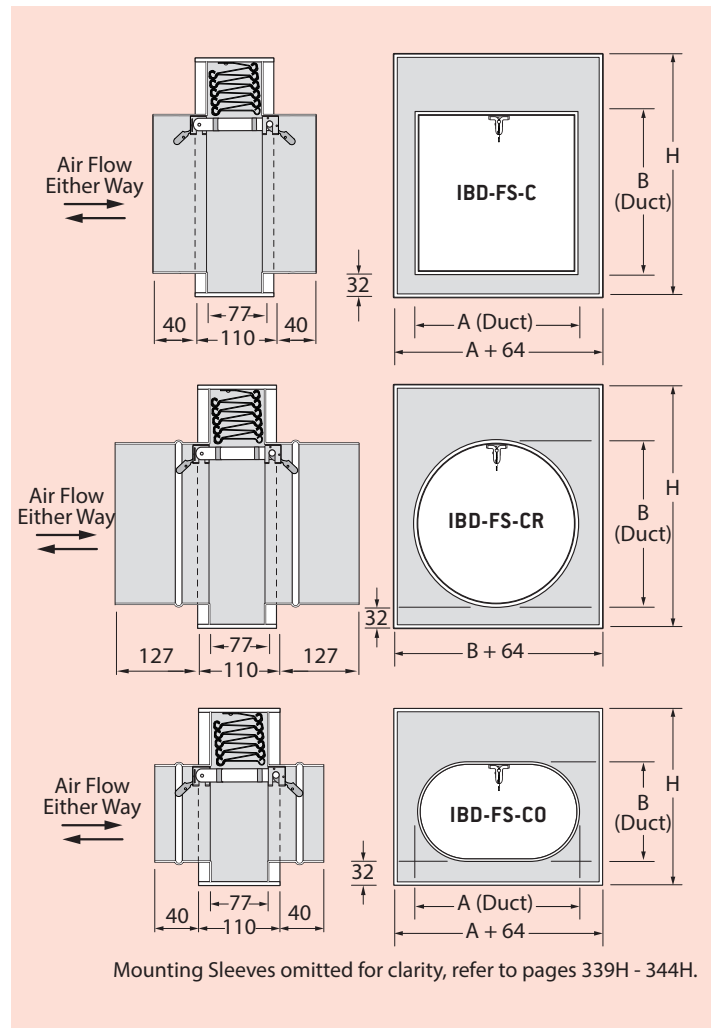

Note: All IBD-FS dampers are fitted with Test Latch Links.

IBD-FS Duct Connection Style 'C', 'CR' & 'CO'

(Single Section Damper Heights).

Dimension 'B'		Dimension 'H' = B +
From	To	
140	326*++	86
327	541	111
542	756	136
757	971	161
972	1014	186

* Restricted minimum (DUCT) height/diameter when fitted with Electro Thermal Resettable Links, (See separate table).

++ For testing purposes below 150 mm will require complete removal of link and blades dropped manually, (IBD-FS-C Only).

Typical Multiple Assembly

In accordance with AS1530.4-2014, where a damper exceeds the the maximum test size it may be built into a modular assembly of dampers, with approval from a registered testing authority.

Maximum multiple unit module for IBD-FS dampers is 3 wide by 2 high single sections.*

Where 'H' requires more than one section, the blade stack for the lower section will be in the air stream.

The extent of this obstruction may be determined from the table to the right, for the appropriate size. Dimension in the right hand column minus 32 mm.

Adequate fire rated bracing must be provided by the installer to prevent collapse of multiple unit assemblies when closed, even under relatively low pressure differential conditions.

Multi section units must be installed with suitable supporting construction to adhere to BCA, or Local Authority Building Control Approval.

The damper assemblies do not provide structural support.

Alternatively, if individual damper sections are installed they must be separated by a minimum of 200 mm of structural support, of the same fire rating as the rest of the surrounding structure and in accordance with AS 1530.4-2014.

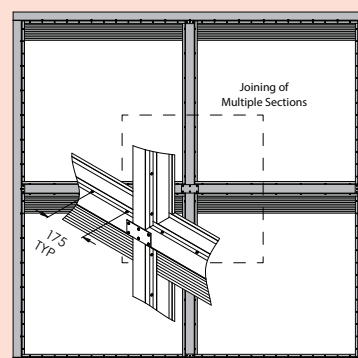

Assembly and Dimensional Information

(A & B Dimensions allow 6 mm clearance for mounting sleeve of nominated size)

Model: IBD-FS-A-H

Interlocking blade, horizontal (floor) mounting damper, constant force spring operated, blade stack located **within air stream**.

Minimum size A 125 x B 180 mm.
Maximum size A 1200 x B 1200 mm.
(Single Section).

Model: IBD-FS-B-H

Interlocking blade, horizontal (floor) mounting damper, constant force spring operated, blade stack located **out of air stream**.

Minimum size A 125 x B 144 mm.
Maximum size A 1200 x B 1046 mm.
(Single Section).

Note: All IBD-FS dampers are fitted with Test Latch Links.

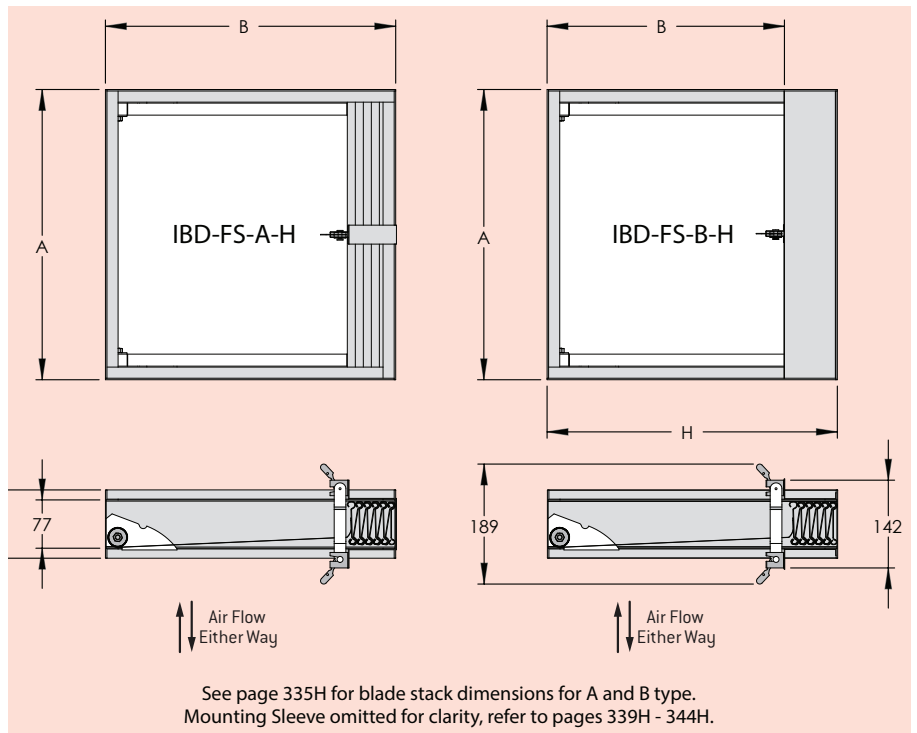

Model: IBD-FS-A-H (multiple)

The IBD-FS multiple is tested in accordance with AS1530.4-2014 and can be built up to a maximum of 3 units wide by 2 units high, giving a maximum damper size of 3600mm x 2400mm.

IBD-FS multiple section fire dampers are supplied with a 65mm wide support mullion between damper sections. This is to meet the pressure requirements of AS1530.4-2014.

• CSIRO

IBD-FS Modular Damper Fire Assessment Short Form Report No. FCO - 3356

(Certified for up to 240 minute fire rating).

Depending on the size of the fire damper and site access considerations the damper may be supplied in parts for on-site assembly. Contact your local Holyoake branch to discuss this option.

The damper assemblies do not provide structural support.

Alternatively, if individual damper sections are installed they must be separated by a minimum of 200 mm of structural support, of the same fire rating as the rest of the surrounding structure and in accordance with AS 1530.4-2014.

See multiple section damper installation details on page 343H for more information.

Model: IBD-FS-B-H (multiple)

See above for details, except Style 'B' assemblies where more than one unit high, would consist of "B" type units in the top and bottom row (as illustrated).

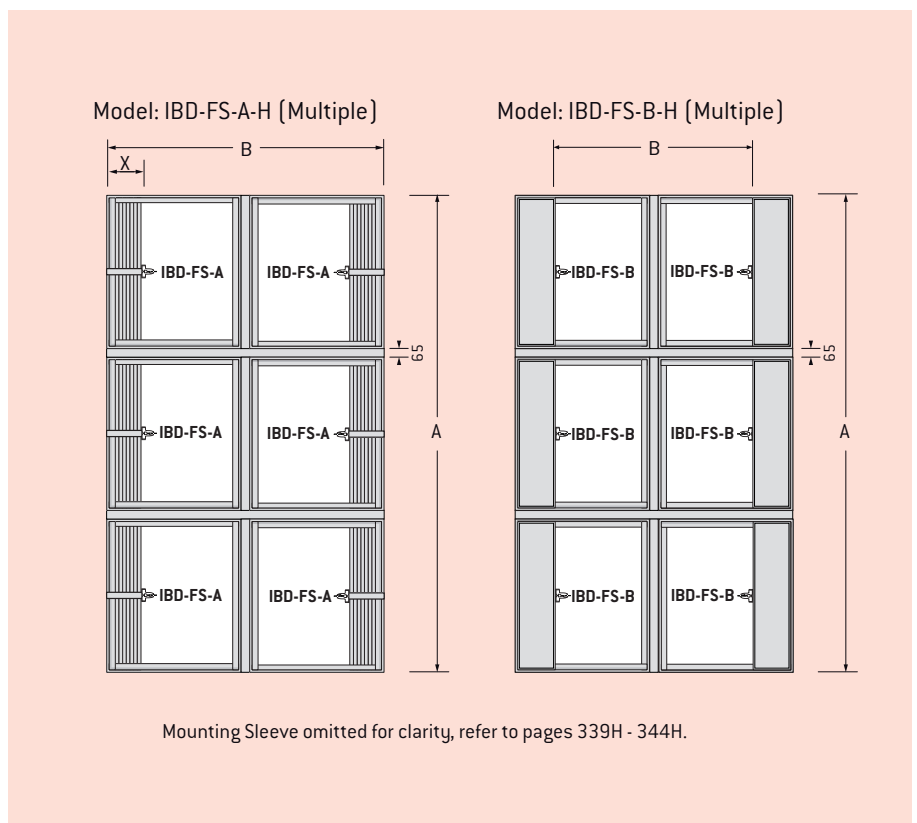

Notes

- In specifying a fire damper the width should always be stated first and the height second [* Maximum diameter 1014 mm].
- Nominal dimensions are opening sizes and allow clearance for insertion into mounting sleeve:
6 mm Duct Connection A & B. 3 mm Duct Connection C, CR & CO.
Where this allowance is not required specify "exact size".

IBD-FS – Fire & Leakage Rated Dampers

Assembly and Dimensional Information

(A & B (Duct) Dimensions allow 3 mm clearance for duct of nominated size).

All IBD-FS-C styles, blade stacks located **out of air stream**.

Model: IBD-FS-C-H

Interlocking blade, horizontal (floor) mounting damper, constant force spring operated, fitted with enclosure plates and square, or rectangular spigots to suit duct connections.

Minimum size A 100 (Duct) x B 140 (Duct).

Maximum size A 1136 (Duct) x B 1014 (Duct), (Single Section).

Model: IBD-FS-CR-H

Interlocking blade, horizontal (floor) mounting damper, constant force spring operated, fitted with enclosure plates and round spigots to suit duct connections.

Minimum size B 150 (Duct Diameter).

Maximum size B 1014 (Duct Diameter), (Single Section).

Model: IBD-FS-CO-H

Interlocking blade, horizontal (floor) mounting damper, constant force spring operated, fitted with enclosure plates and oval spigots to suit duct connections.

Minimum size A 100 (Duct) x B 150 (Duct).

Maximum size A 1136 (Duct) x B 1014 (Duct), (Single Section).

Note: All IBD-FS dampers are fitted with Test Latch Links.

IBD-FS Duct Connection Style 'C', 'CR' & 'CO'

(Single Section Damper Heights).

Dimension 'B'		Dimension 'H' = B +
From	To	
140	- 326**	86
327	- 541	111
542	- 756	136
757	- 971	161
972	- 1014	186

* Restricted minimum (DUCT) height/diameter when fitted with Electro Thermal Resettable Links, (See separate table).

** For testing purposes below 150 mm will require complete removal of link and blades dropped manually, (IBD-FS-C Only).

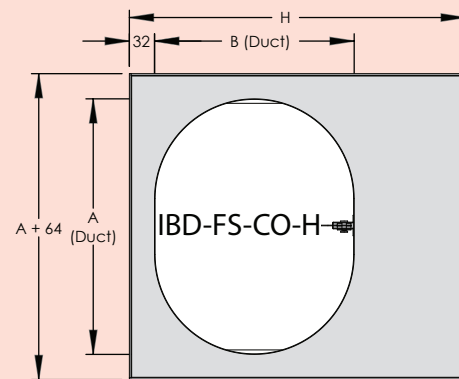
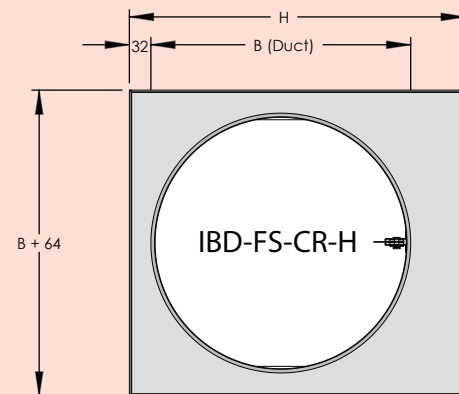
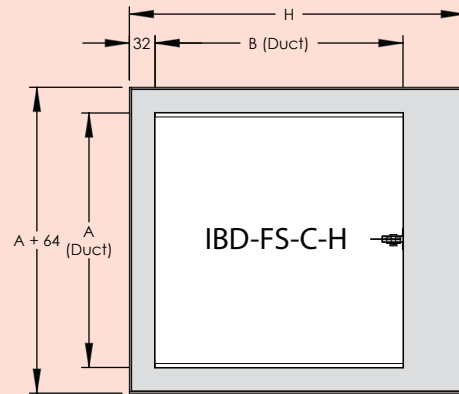
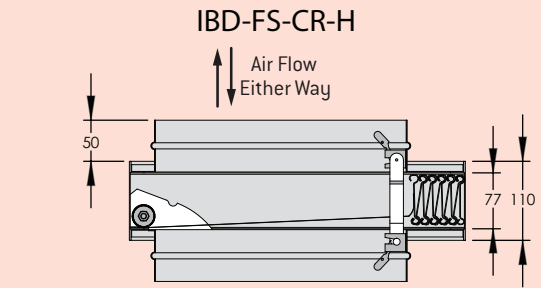

Mounting sleeves omitted for clarity, refer to pages 339H - 344H.

Damper Installation

The following installation method and diagrams (shown on the following pages), are presented as the method by which **Holyoake IBD-FS fire and leakage rated dampers must be installed.**

It draws upon SMACNA fire, smoke and radiation damper installation guide for HVAC systems, fifth edition, 2002 and Standard AS 1682.1 and 1682.2

Dampers must be installed as tested.

- (I) The casing shall completely penetrate the wall and be retained:
 - (A) on both sides by four 40 x 60 x 2 mm mounting angles, in such a manner that it can expand in a fire without distorting the blades in a closed position; or
 - (B) on the accessible side only by four 40 x 60 x 2 mm mounting angles. These can be fixed to the fire damper and to the fire barrier through oversized holes and penny washers. Fixings should be finger tight (to allow movement for thermal expansion) but locked, i.e. with double nut (lock nut).

Mounting angles^{3,4,5} shall be butted against the face of the wall and fixed to the fire damper casing. The width of the angle section on the separating element shall be not less than twice the clearance between the fire damper body and the penetration.

- (II) The fire and leakage rated damper shall be installed so that the airflow¹ does not impede its closure, and air velocities² do not exceed the damper's limit (10 m/s).
- (III) The method of attachment of ductwork to the fire and leakage rated damper must be such that any deformation, or collapse of the ductwork in a fire, does not dislodge the fire and leakage rated damper, or affect its performance. This is best achieved by the use of slip joints which will allow damaged ductwork to fall away. Refer to "Breakaway Joints" within AS 1682.1 and AS 1682.2.
- (IV) IBD-FS fire dampers do not require packing between the sleeve and penetration (both vertical and horizontal).
- (V) **Clearance** between the sleeve and penetration should be such that the hole size may be no less than the overall sleeve size plus **22mm** in both width and height, as in the tested prototype. However, in no case should total clearance exceed 50% of the angle face width. For Multiple Section fire dampers the clearance shall be **30mm**, see pg 343H for further details.

- (VI) Dampers must have a minimum damper separation of 200mm between dampers installed in separate ducts or 75mm between the damper and an adjacent construction element. (See page 343H).
- (VII) Access doors, or removable pressed panels, must be provided for duct entry, to test and reset release mechanisms and to inspect the fire and leakage rated damper.
- (VIII) When installed and closed, the blade and pivots must be fully contained within the penetrated element and within the casing, as tested (AS 1530.4 - 2014).
- (IX) Curtain type fire and leakage rated dampers may not be used as control dampers. i.e. they must be installed fully open.
- (X) All Holyoake IBD-FS type fire and leakage rated dampers must be sleeve mounted using the factory fitted sleeves and angles^{3,4,5}. **See details on following pages.**
- (XI) Series IBD-FS fire and leakage rated dampers must not be installed either with blades vertical (on end) or with the blade stack below the opening.

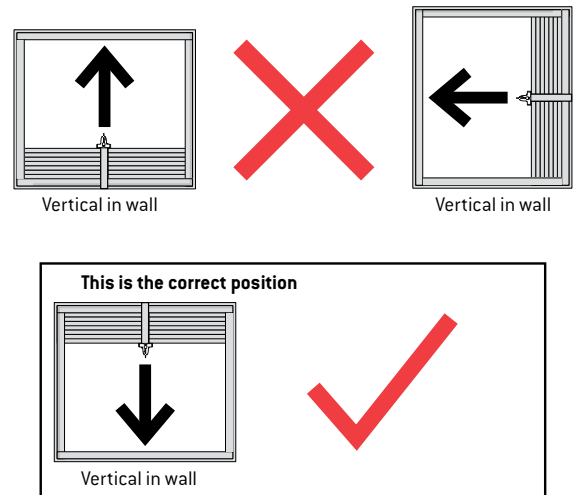

- (XII) Ensure damper is square and free from racking, that there are no obstructions in the center track, and that it is installed vertically in accordance with the "this way up" arrow on every damper. (See Page 334H).
- (XIII) IBD-FS fire dampers must include a completed installers label (supplied) compliant with AS 1682.2 - 2015.

Notes

- 1 Air flow may be from either direction for Holyoake Series IBD-FS.
- 2 While damper size influences acceptable velocities (i.e. the larger the damper the lower the velocity), Holyoake suggests a maximum of 10 m/s on IBD-FS dampers. Pressure differential across the closed damper should not exceed 750 Pa.
- 3 The damper and fixed retaining angles are factory fitted to the sleeves. The loose angles must be fixed to the factory fitted sleeve (no extensions) through pre-punched holes for the appropriate number of site fixings. (Optional fixing screws can be provided).
- 4 Retaining angles are a minimum thickness of 2 mm, as tested (AS 1530.4 - 2014). They are mandatory on all four sides of at least one face, but need not be welded to form a frame.
- 5 Materials for sleeves and retaining angles comply with AS 1682.1 and AS 1682.2 - 2015 and AS 1530.4 - 2014 as tested, which specifies using galvanised steel with a coating class of not less than Z275.
- 6 Fire damper certifications are consistently updated, contact your local Holyoake branch for updated installation details and compatible wall/floor constructions.

IBD-FS – Fire & Leakage Rated Dampers

Vertical Damper Installation

IBD-FS Fire and Leakage Rated Damper, Installation Various Styles in a Masonry Wall.

Fire & Leakage Rated Dampers

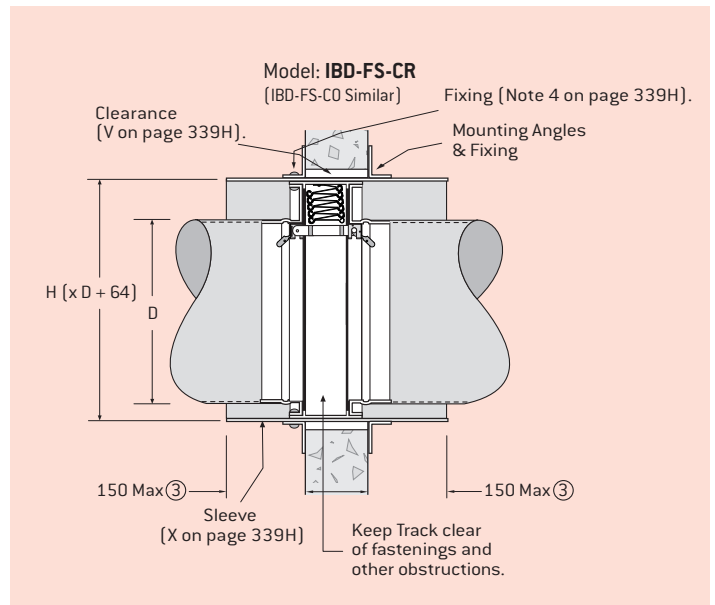
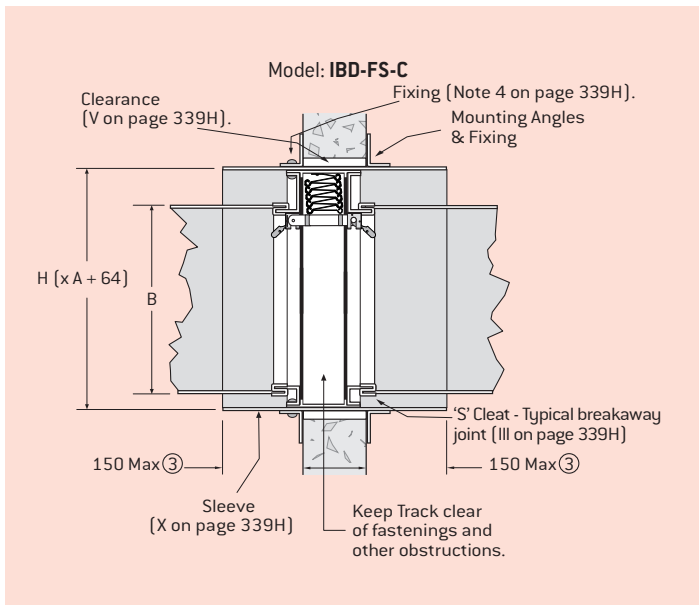
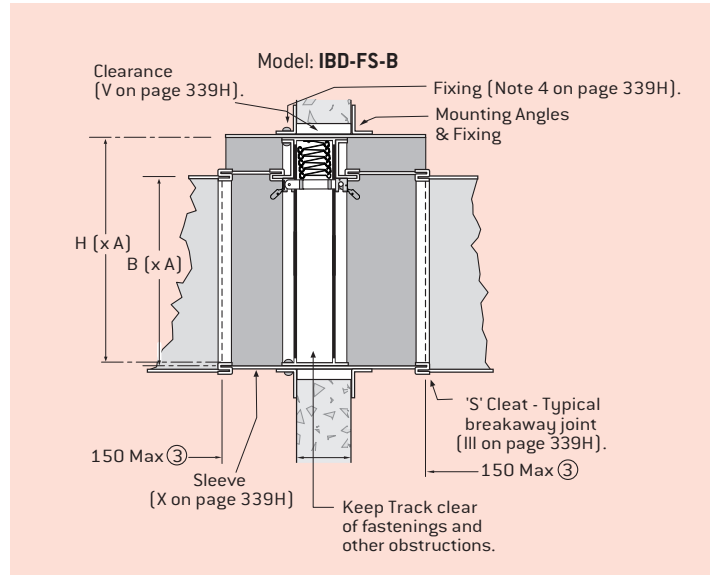
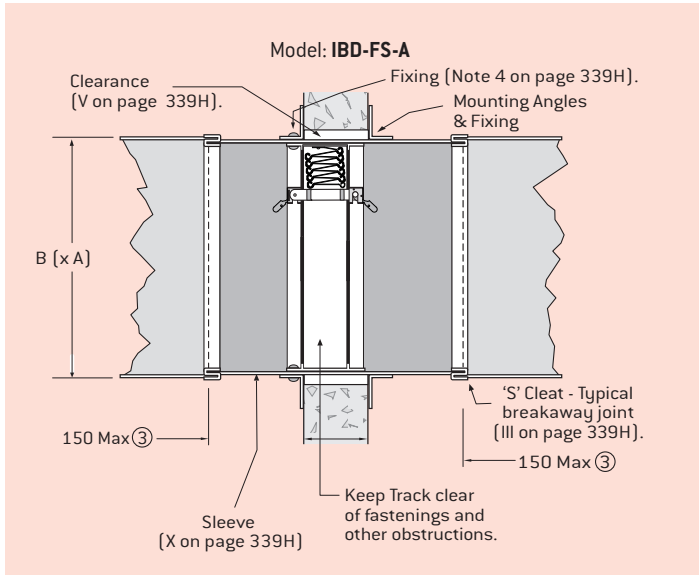

Guide Product Weights	
IBD-FS Curtain Fire Dampers	Approximate Weight in Kg
IBD-FS-A 200 x 200	2.1
IBD-FS-A 600 x 600 (Inc Sleeve)	16.47
IBD-FS-B 206 x 500	4.6
IBD-FS-B 250 x 250	3.56
IBD-FS-B 400 x 375	6.34
IBD-FS-B 760 x 560	12.79
IBD-FS-B 1050 x 700	11.61

Guide Product Weights	
IBD-FS Curtain Fire Dampers	Approximate Weight in Kg
IBD-FS-B 350 x 350 (Inc Sleeve)	16.09
IBD-FS-B 400 x 375 (Inc Sleeve)	16.36
IBD-FS-B 500 x 350 (Inc Sleeve)	19.73
IBD-FS-CR 150 Diameter	3.16
IBD-FS-CR 200 Diameter	4.15
IBD-FS-CR 250 Diameter	5.21
IBD-FS-CR 450 Diameter	10.8
IBD-FS-CR 400 Diameter (Inc Sleeve)	23.75

Notes

1. Refer to Damper Installation and Notes on Page 339H.
2. For 'H' dimension refer to tables on pages 335H - 338H.
3. Refer to Construction Note 6 on Page 344H.
4. Above details are intended as a guide for field installation of sleeves.

Vertical Damper Installation

IBD-FS Fire and Leakage Rated Damper, Installation in a Plasterboard Wall.

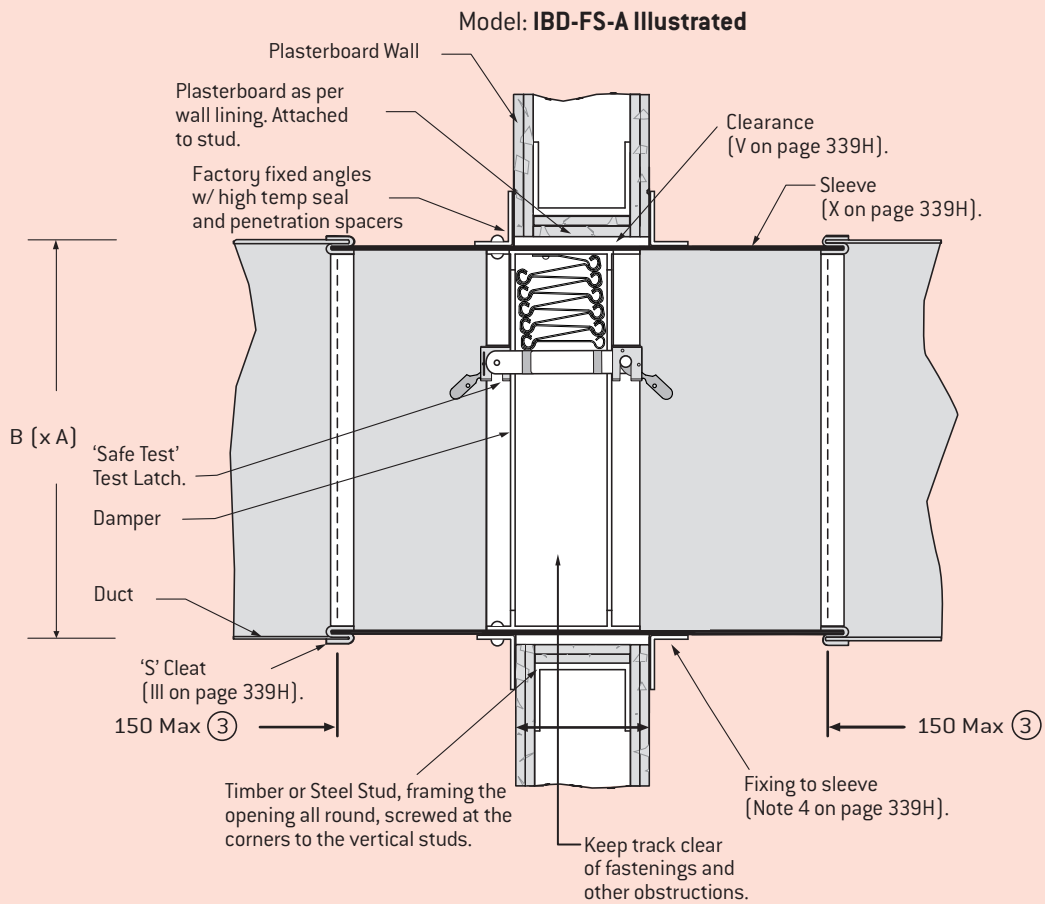

(IBD-FS-B, C, CR & CO similar, with duct connections as per masonry drawings on page 340H).

Duct attachment method for the IBD-FS-B in Sleeve

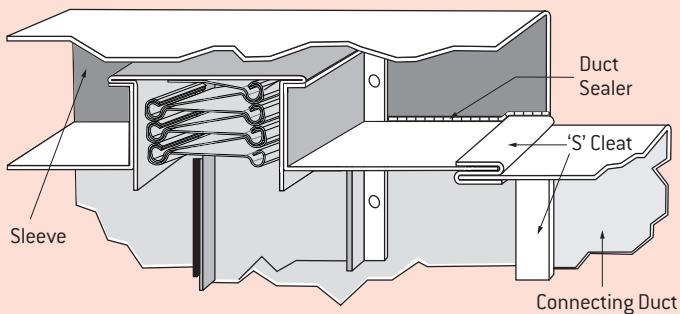

Notes

1. Refer to Damper Installation and Notes on Page 339H.
2. For Various Duct Connection Styles refer to page 340H.
3. Refer to Construction Note 6 on Page 344H.
4. Above details are intended as a guide for field installation of sleeves.

IBD-FS – Fire & Leakage Rated Dampers

Horizontal Damper Installation

For IBD-FS Horizontal in a concrete slab floor.

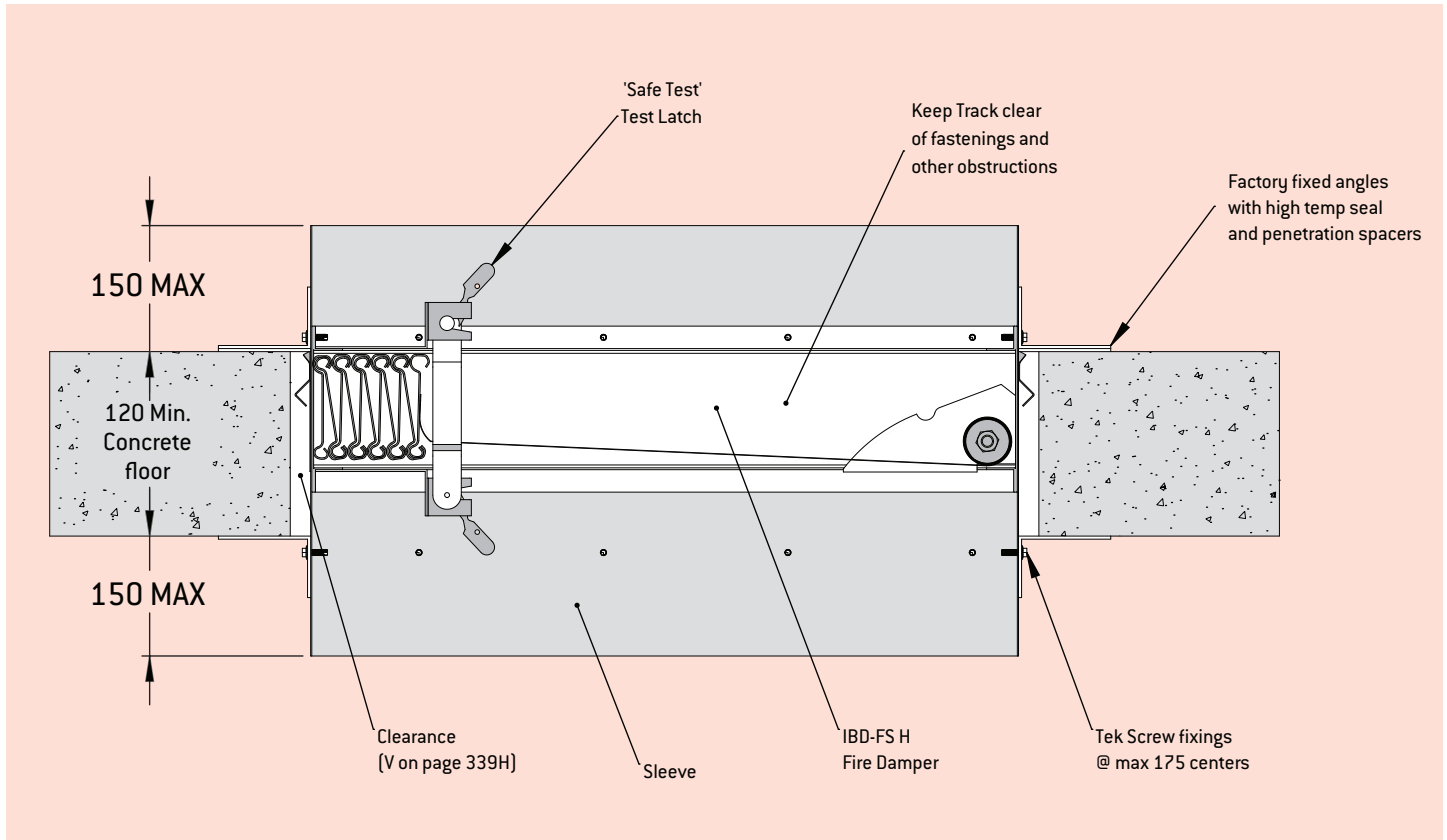

IBD-FS horizontal specific instructions

Dampers must be installed as tested.

- (I) The Factory fixed angles must be located on the top of the penetration in accordance with the "this way up" label on every damper. The blade catch bracket must be oriented as illustrated in the above figure.
- (II) Attachments between damper and riser ducts do not require breakaway joints provided that the riser shaft only contains building services. See AS1682.2-2015 for full details of this.
- (III) Where insulated ductwork mounted above the fire damper is required under AS1668.1-2015, it shall be installed so that it will not breakaway or collapse in a fire.
- (IV) IBD-FS horizontal fire dampers include a blade catch to ensure a positive lock of the blades on closure. To release when testing, the blades must be pulled tight to create tension to disengage the catch.

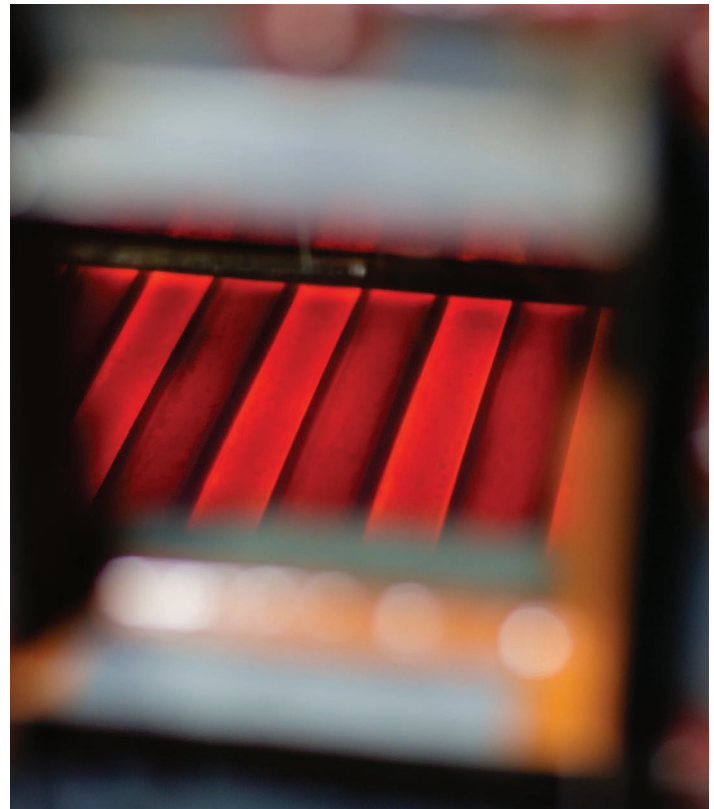

IBD-FS Horizontal AS1530.4 certification testing.

Multiple Section Fire Dampers Installation

IBD-FS Fire and Leakage Rated Damper Assembly for oversize openings.

Multiple sections dampers are installed as per single section dampers. See either IBD-FS V or H instructions for full details of the installation and requirements.

Multi-section IBD-FS fire dampers must be installed with a **30mm** total expansion gap (as tested)

IBD-FS multiple section dampers can be installed as one oversized duct or as multiple ducts through a single penetration.

Depending on the size of the fire damper and site access considerations the damper may be supplied in parts for on-site assembly. Contact your local Holyoake branch to discuss this option.

Adequate fire rated bracing must be provided by the installer to prevent collapse of multiple unit assemblies when closed, even under relatively low pressure differential conditions.

Multi section units must be installed with suitable supporting construction to adhere to BCA or Local Authority Building Control Approval.

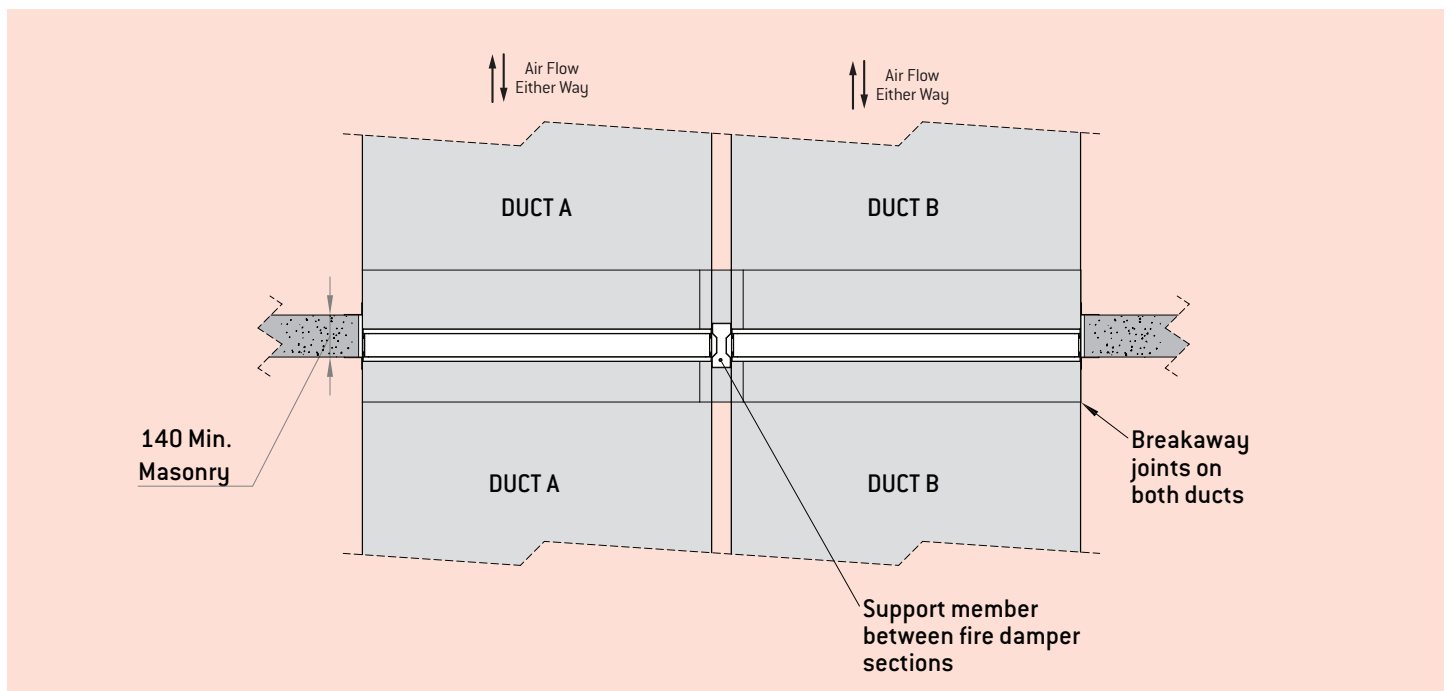
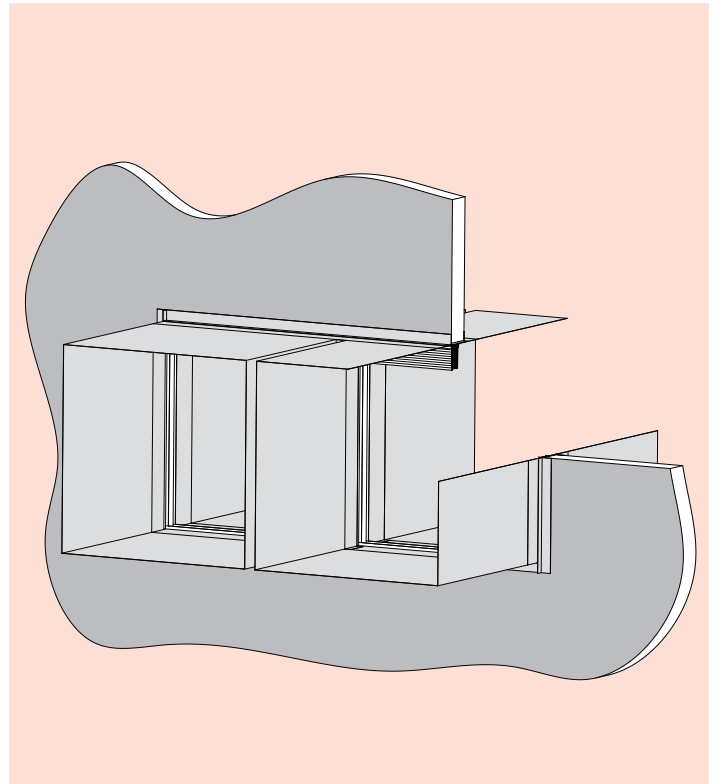

Multiple duct installation

Where a 200mm separation between fire dampers cannot be met duct bridging pieces can be used. The 65mm wide support mullion is used between fire damper sections to create a single fire rated penetration. This allows multiple ducts to pass through a fire wall without the need for a 200mm separation between fire dampers.

Contact your local Holyoake branch to discuss this option.

IBD-FS – Fire & Leakage Rated Dampers

IBD-FS Factory Fitted Mounting Sleeves

Holyoake Fire and Leakage Rated Damper Sleeves.

Model IBD-FS fire and leakage rated damper mounting sleeves are constructed as tested to AS1530.4-2014

(Refer also to Page 339H, Damper Installation and Notes).

Two standard sleeve lengths are available, 380mm and 450mm which are suitable for wall/floor thicknesses of 78 -230mm and 230-370mm.

However, optional variable length sleeves are available on request.

Mounting angles are supplied. One set is fixed to one end of the sleeve and the other is supplied loose, for final fixing of these to the sleeve, on site, by others.

All IBD-FS sleeves are supplied factory fixed to the appropriate damper.

Minimum Wall Thickness:

380mm Standard Sleeve 90 mm.
450mm Standard Sleeve 230 mm.

Maximum Wall Thickness:

380mm Standard Sleeve 230 mm.
450mm Standard Sleeve 370 mm.

Material:

Galvanised Steel Type Z275.

Minimum Dimension:

100 W x 160 mm H (Type IBD-FS-A Only – Refer to pages 335H - 342H and 341H).

Maximum Dimension Thickness

3600 W x 2400 mm H. 0.75 mm.

Flanges

40 x 60 x 2 mm galvanised steel angle. (x4 per side, x 2).

Construction

Sleeves are corner lapped and spot-welded, then attached to the damper frame on all four sides, to form a rigid assembly.

- All damper sleeves come with raw edges.
- Optional 'S' cleats on all edges (Typical Breakaway Joint).
- Optional 25 or 35 mm Breakaway flange on all edges.
Do NOT use bolts or 'no bolt corner clips' for Fire Damper Breakaway Joints, (Optional PVC cleats and nylon bolts are available).
(Typical Breakaway Joint – refer to Section K Accessories).
- Type 'B' damper sleeves are fitted with a duct bridging piece.
- An extended damper sleeve is available for wall depths 291 – 690 mm, (specify length required when ordering).
Supplied only as part of a complete unit.
- Casing sleeve may only be extended 150 mm from the face of the wall on each side, with either slip or flanged breakaway connections.

If in excess of these dimensions sleeve should be trimmed back to the appropriate lengths. This then complies with AS 1682, Parts 1 & 2, 2015.

Standard or Extended Sleeve					
Style	A	B	C	CR	CO
Width	A - 3	A - 3	A + 67	D + 67	A + 67
Height	B - 3	H + 3	H + 3	H + 3	H + 3

Typical IBD-FS Installation

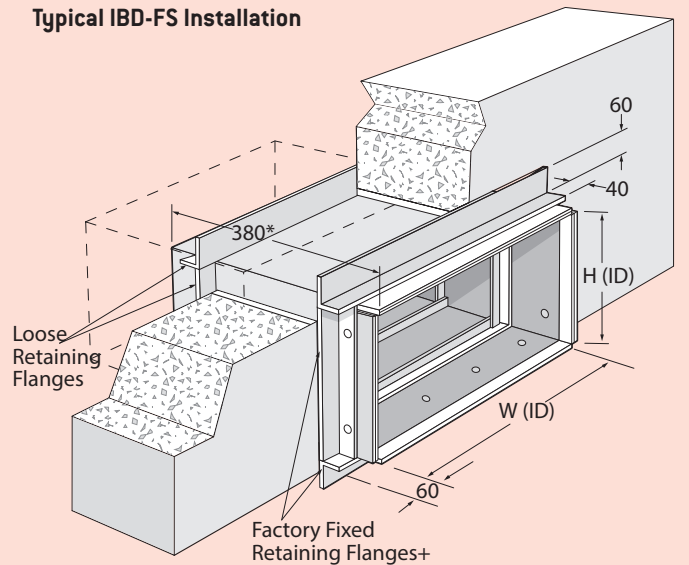

* Standard length. Specify alternative if required.

Typical Assembly - Standard IBD-FS Damper Sleeve

(B Type Damper Illustrated)

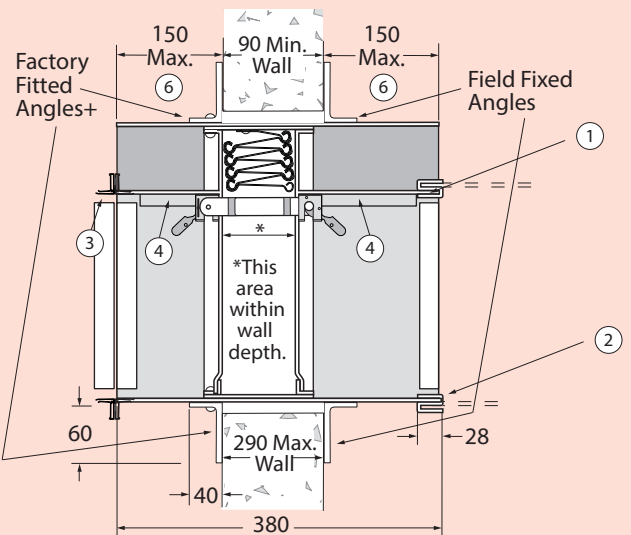

Typical Assembly - Optional Extended Damper Sleeve

(A Type Damper Illustrated)

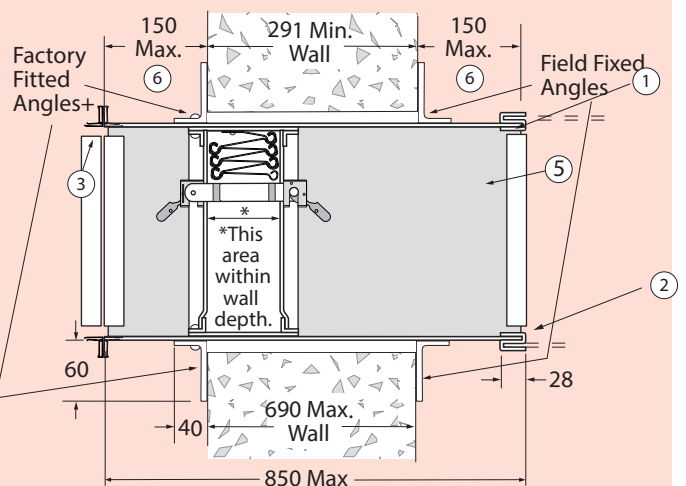

'Safe Test' - Test Latch Model IBD-TL

- **Safe and Simple Testing Method.**
- **Test and Reset in minutes.**
- **AS 1851 - 2012 (Section 13) requires that you annually test Fire Dampers.**
- **To ensure the Life and Property saving function for which they are designed, all fire dampers should be drop tested after installation.**
- **Note: All IBD-FS dampers are fitted with 'Safe Test' Test Latch Links, as tested and certified.**

Each Holyoake Series IBD-FS Fire and Leakage Rated Damper is mechanically tested before it is allowed to leave the factory. In the event of damage occurring during transit, on site, or during installation, rendering any fire damper ineffective, failure to function will reveal any warping, track obstruction, or spring failure that may have occurred. This will require rectification, cleaning and removal of the obstacle, prior to retesting and handover.

The Holyoake 'Safe Test' Test Latch Model IBD-TL, is a latching device with a specially made fusible link, which, when the latch is released, swings clear and allows the curtain to close as if the link had parted under the influence of flame.

After testing, the curtain can be re-stacked and the same link clipped back into the latch, where it is again ready to be released in the event of a fire.

To Operate IBD-FS Dampers

1. Remove the duct access door (refer to Section K accessories section of this manual).
2. Using this access, reach in and remove the locking pin from the nearest latch.
3. Check that the locking pin is still in place on the other latch, so that the fusible link is retained by it, when released.
4. Check that the track is clear of any obstruction and keep hands clear.
5. Lift the latch lever and the curtain will rapidly close.
6. Reload the curtain and swing the fusible link back into place in the latch.
7. Replace the locking pin in the latch.
8. Replace the duct access door.

To Operate IBD-FS Dampers below minimum heights shown.

1. Remove the duct access door (refer to Section K accessories section of this manual).
2. Remove locking pin from both sides.
3. Check that the track is clear of any obstruction and keep hands clear.
4. Support the blade pack, lift both latch levers and remove fusible link.
5. Release the blade pack and the curtain will rapidly close.
6. Reload the curtain and support the blade pack, whilst replacing the fusible link locating pins into both latches.
7. Replace both locking pins.
8. Replace the duct access door.

Minimum Duct Height for dampers fitted with Electro Thermal Resettable Links	
Duct Connection Style	Minimum Duct Height
A	240
B	180
C	180
CR	180
CO	180

For testing purposes, all dampers below these heights will require removal of link and blades dropped manually.

Note: Take suitable safety precautions for Hand and Eye protection.

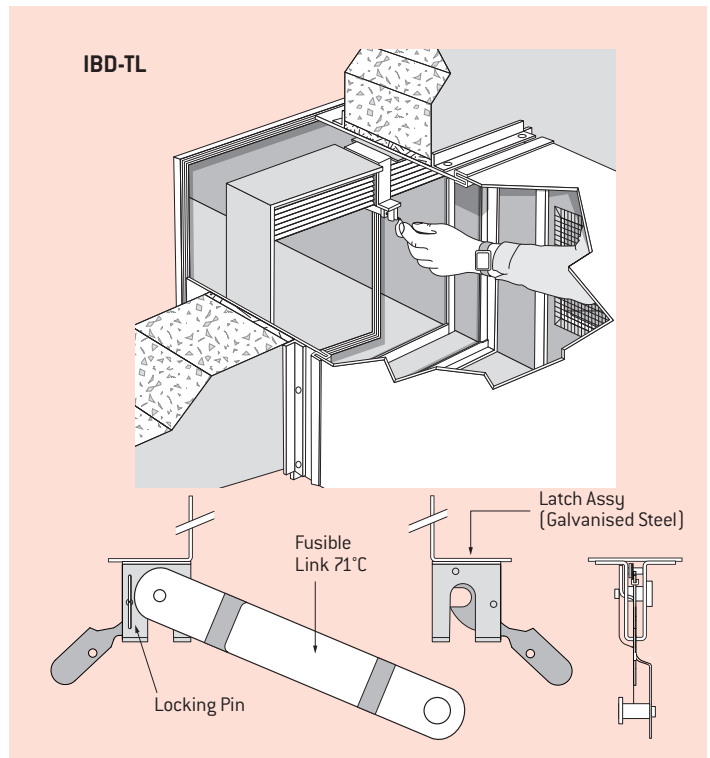

Electro Thermal Resettable Links Model: IBD-ETR

All Holyoake IBD-FS type fire and leakage rated dampers, are available with optional Electro Thermal Resettable Link mechanisms.

Contact your local Holyoake branch for details.

24 V AC or DC Supply Electro Thermal Resettable Release.
Max 30 Sec Release and 60 Sec Reset, with integral 71°C Thermal Resettable Release.

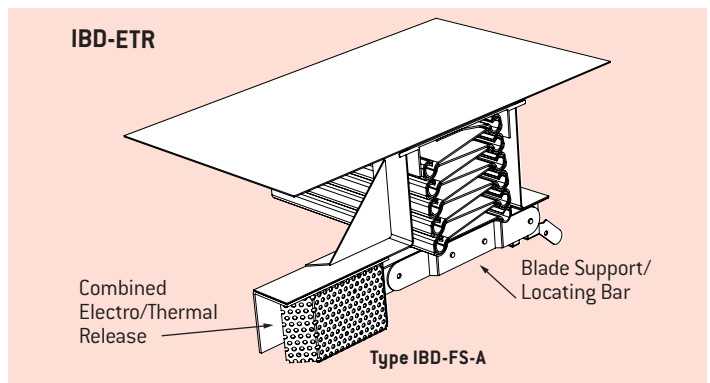

Maximum Damper size with IBD-ETR is 750 x 750 mm.

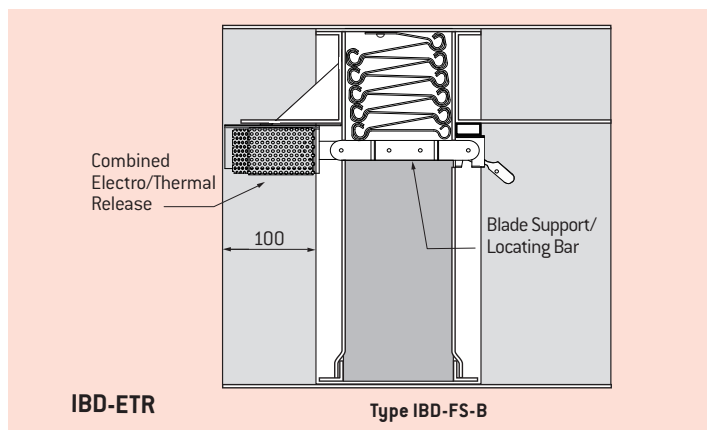

IBD-FS – Fire & Leakage Rated Dampers

Model: IBD-FS-A

AREA FACTOR TABLE - DUCT CONNECTION STYLE A												
Dim. 'B'	Dimension 'A' Width (mm)											
(mm)	100	200	300	400	500	600	700	800	900	1000	1100	1200
184		55.90	33.90	24.30	19.00	15.60	13.20	11.40	10.10	9.00	8.18	7.47
304	82.70	29.00	17.60	12.60	9.83	8.06	6.83	5.92	5.23	4.68	4.24	3.87
424	55.80	19.60	11.90	8.51	6.63	5.44	4.61	3.99	3.53	3.16	2.86	2.61
544	42.10	14.80	8.95	6.42	5.01	4.10	3.48	3.01	2.66	2.38	2.16	1.97
664	33.80	11.80	7.18	5.15	4.02	3.29	2.79	2.42	2.14	1.91	1.73	1.58
784	28.20	9.90	6.00	4.31	3.36	2.75	2.33	2.02	1.79	1.60	1.45	1.32
904	24.20	8.50	5.15	3.70	2.88	2.36	2.00	1.74	1.53	1.37	1.24	1.13
1024	21.20	7.45	4.51	3.24	2.53	2.07	1.75	1.52	1.34	1.20	1.09	0.99
1144	18.90	6.63	4.02	2.88	2.25	1.84	1.56	1.35	1.19	1.07	0.97	0.88
1200	17.00	5.97	3.62	2.60	2.02	1.66	1.41	1.22	1.08	0.96	0.87	0.80

[All dimensions include 6 mm clearance total between outside of damper frame and inside of duct].

For pressure drop through an open IBD-FS-A fire and leakage rated damper, use the following procedure:

1. Find the Area Factor from the above table, enter duct width and height. For horizontal dampers multiply the area factor by the correction factor on the right.
2. Determine Conversion Velocity (CV) by multiplying Area Factor by flow in m³/s [CV = Area Factor x m³/s].
3. Enter pressure drop chart with Area Factor and establish intersection with Conversion Velocity (CV) line just determined. Read pressure drop on left hand side of the chart.

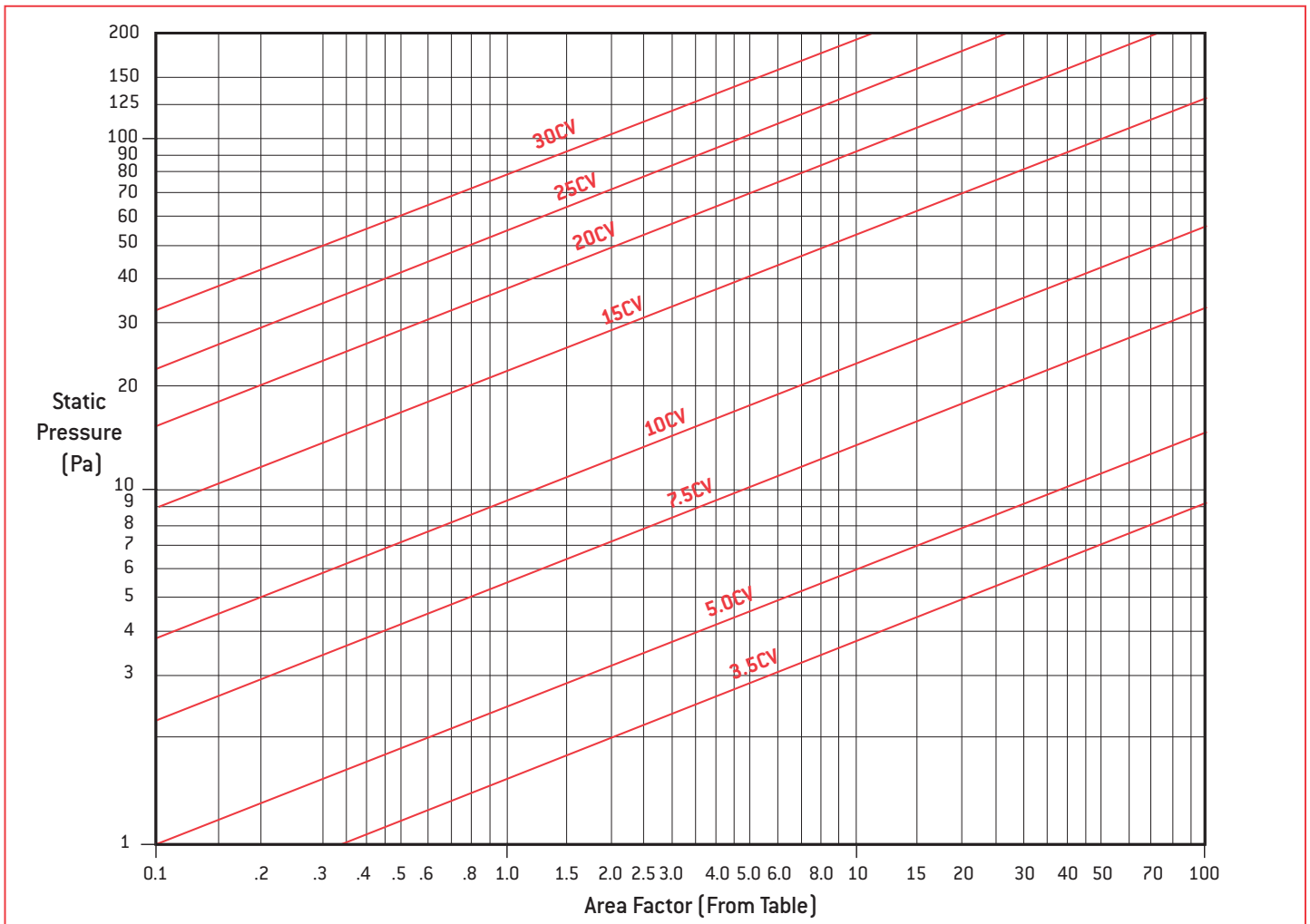
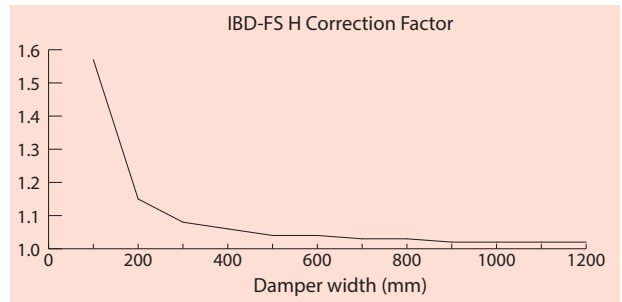

Notes

1. Static Pressure and Conversion Velocities are correct for 1.2 kg/m³ air density.
2. Ratings are based on dampers installed in accordance with details in this catalogue, with ductwork upstream and downstream.

Model: IBD-FS-B

AREA FACTOR TABLE - DUCT CONNECTION STYLE B												
Dim. 'B' (mm)	Dimension 'A' Width (mm)											
	100	200	300	400	500	600	700	800	900	1000	1100	1200
84			67.90	48.70	38.00	31.10	26.40	22.90	20.20	18.10	16.40	14.90
179		42.40	25.70	18.50	14.40	11.80	9.99	8.67	7.65	6.85	6.20	5.66
299	67.80	23.80	14.40	10.40	8.07	6.61	5.60	4.86	4.29	3.84	3.48	3.17
394	50.30	17.60	10.70	7.68	5.99	4.91	4.16	3.60	3.18	2.85	2.58	2.35
514	37.90	13.30	8.07	5.79	4.51	3.70	3.13	2.72	2.40	2.15	1.94	1.78
609	31.80	11.10	6.75	4.85	3.78	3.10	2.62	2.27	2.01	1.80	1.63	1.49
729	26.30	9.24	5.60	4.02	3.13	2.57	2.18	1.89	1.67	1.49	1.35	1.23
824	23.20	8.14	4.93	3.54	2.76	2.26	1.92	1.66	1.47	1.31	1.19	1.09
944	20.20	7.07	4.29	3.08	2.40	1.97	1.67	1.44	1.28	1.14	1.03	0.94
1046	18.30	6.41	3.89	2.79	2.17	1.78	1.51	1.31	1.16	1.03	0.94	0.86

(All dimensions include 6 mm clearance total between outside of damper frame and inside of duct).

For pressure drop through an open IBD-FS-B fire and leakage rated damper use the following procedure:

1. Find the Area Factor from the above table, enter duct width and height.
2. Determine Conversion Velocity (CV) by multiplying Area Factor by flow in m^3/s [$CV = \text{Area Factor} \times m^3/s$].
3. Enter pressure drop chart with Area Factor and establish intersection with Conversion Velocity (CV) line just determined. Read pressure drop on left hand side of the chart.

Note: Interpolations while not precise, are adequate for most calculations.

EXAMPLE:

Find the pressure drop across a 500 wide x 514 high model IBD-FS-B fire and leakage rated damper, passing 2.2 m^3/s .

1. From the table using interpolation, the Area Factor is 4.51.
2. $CV = 2.2 \times 4.5 = 9.9$ [10].
3. From pressure drop chart, pressure drop is 8 Pa.

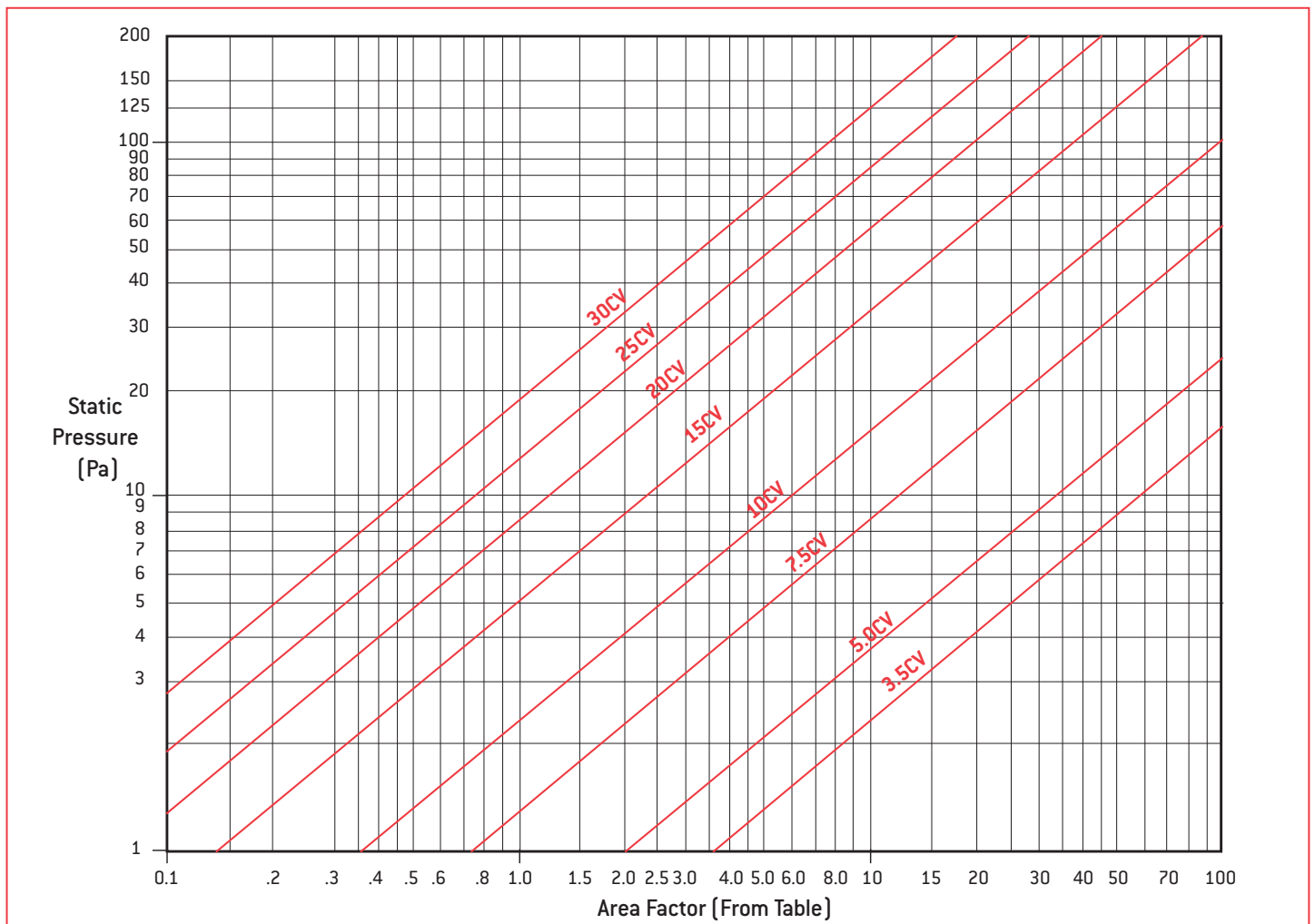

Notes

1. Static Pressure and Conversion Velocities are correct for 1.2 kg/m^3 air density.
2. Ratings are based on dampers installed in accordance with details in this catalogue, with ductwork upstream and downstream.

IBD-FS – Fire & Leakage Rated Dampers

Product Ordering Key and Suggested Specifications

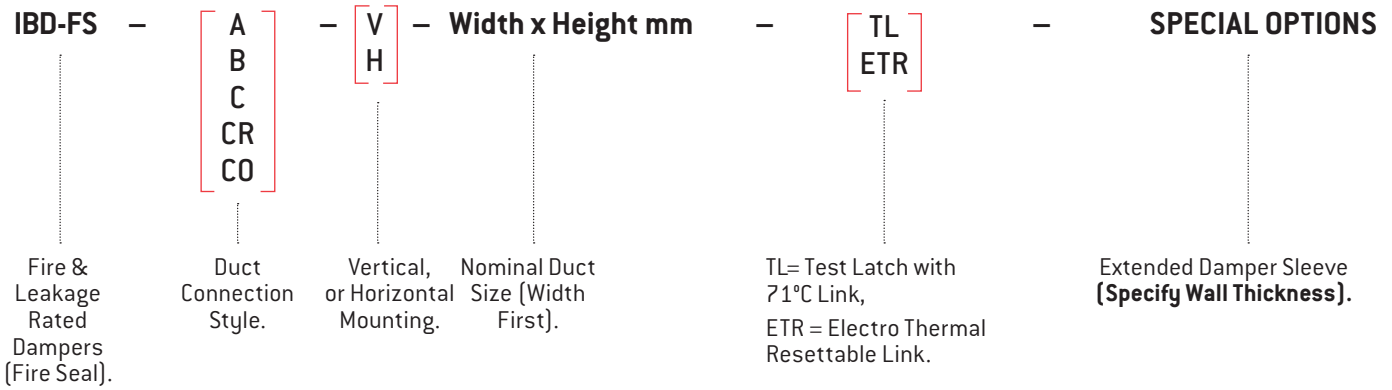

Fire and Leakage Rated Dampers shall be interlocking blade, curtain type, with stainless steel side seals conforming to AS 1530.4 - 2014 leakage requirements and having up to 4 Hour Fire rating.

Fire and Leakage Rated Dampers shall be for Vertical and Horizontal mounting and close by means of a Fusible Link rated at 71°C, or by means of an Electro Thermal Resettable Release Device, incorporating a 71°C Thermal Resettable Release.

“Safe Test” Test Latches and access doors shall be provided so the fire dampers may be test operated at regular intervals after installation, without destroying the fusible links and annually in accordance with AS 1851 - 2012 (Section 13), Routine service of fire protection systems and equipment.

Fire and Leakage Rated Dampers shall be installed in Walls and Floors, utilising factory fitted galvanised steel mounting sleeves and flanges as detailed in AS 1682.1 and AS 1682.2 - 2015 and AS 1530.4 - 2014, and as shown in the manufacturers instructions and drawings within this manual.

Fire and Leakage Rated Dampers shall be Holyoake Series IBD-FS (Fire Seal).

