



ACCESSORIES

AD	Access Doors	383K	RAV	Round Air Valve	370K
APP	Access Pressed Panels	385K	RBD	Round Backdraft Damper	371K
AS	Air Scoop	375K	RD	Radial Balancing Damper	368K
CH	Cushion Heads & Adaptors	376 & 386K	RRA	Rectangular to Round Adaptor	377K
DH	Duct Hangers	371K	SAB	Self Aligning Bends	374K
DUCT FLANGE	Flanging System	383K	SB	Sectorising Baffles	367K
DUCT TAPE	Duct Tape	376K	SC	Spin Collars/Connectors	378K
EG	Equilising Grid	368K	SP/SPM	Single Blade/Motorised Damper	369K
FIXINGS	Fixings & Concealed Fixings	384K	SRA	Square to Round Adaptor	377K
LUFTEC	Luftec Actuators	372 - 373K	SSA	Square to Square Adaptor	377K
OBD	Opposed Blade Dampers	366K	SSV	Stainless Steel Vent	370K
PDI/PDIA	Flow Measuring/Balancing Stations	379 & 382K	SSD	Stream Splitter Damper	375K
PDI/PDIA	Sensor Flor Rates	380 - 381K	TRV	Throw Reducing Vanes	367K
PREMI-AIRE	Pre-Insulated Duct/Accessories	386 - 390K	TV	Turning Vanes	374 & 382K
				Ordering Key & Specifications	389 - 390K

ACCESSORIES – Opposed Blade Dampers

Models: **OBD-1**, **OBD-2** and **OBD-3**

Control dampers for fixed volume balancing and adjustment. Available in three configurations for the following applications:

- OBD-1:** Sidewall, eye-lash and bar grilles with screwdriver operator. Extruded black anodised aluminium construction.
- OBD-2:** Ceiling diffusers - square and rectangular multi-pattern (CMP Series) and perforated square neck (CP Series) with screwdriver operator. Extruded black anodised aluminium construction.
- OBD-3:** Duct mounting - for small branch ducts which require fixed dampening. Has a special operator system which allows adjustment from side of duct. Extruded black anodised aluminium construction.

Construction is robust, using extruded aluminium, with stainless spring steel friction wire. These dampers are not intended for tight shut off or where frequent adjustment is required.

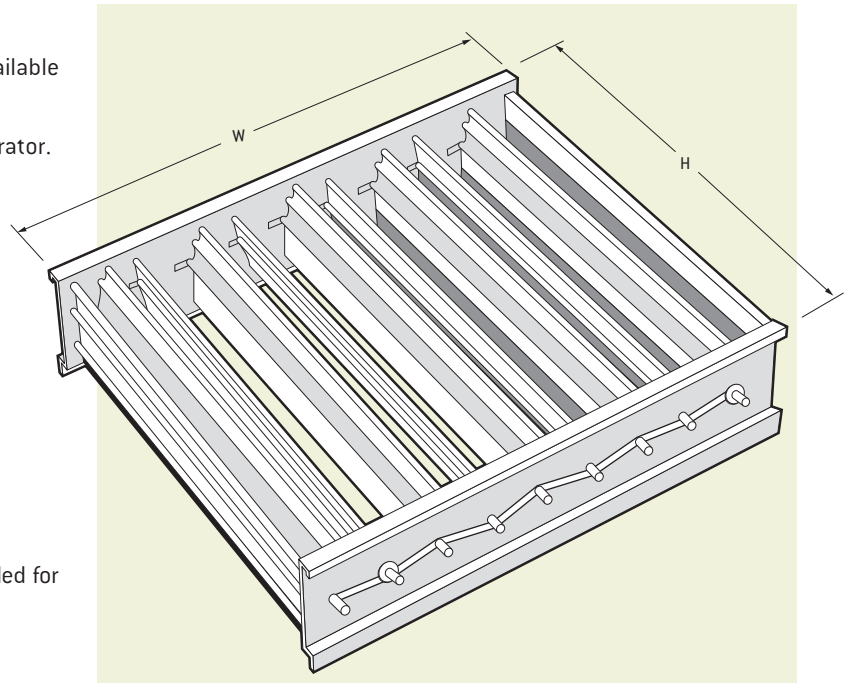

Guide Product Weights	
Size	Approximate Weight in Kg.
	200 x 200
300 x 300	OBD-1 0.80

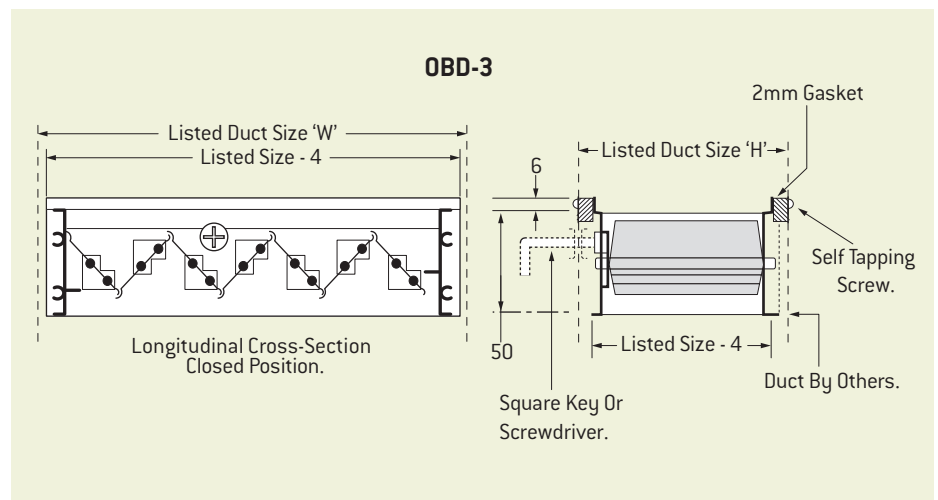
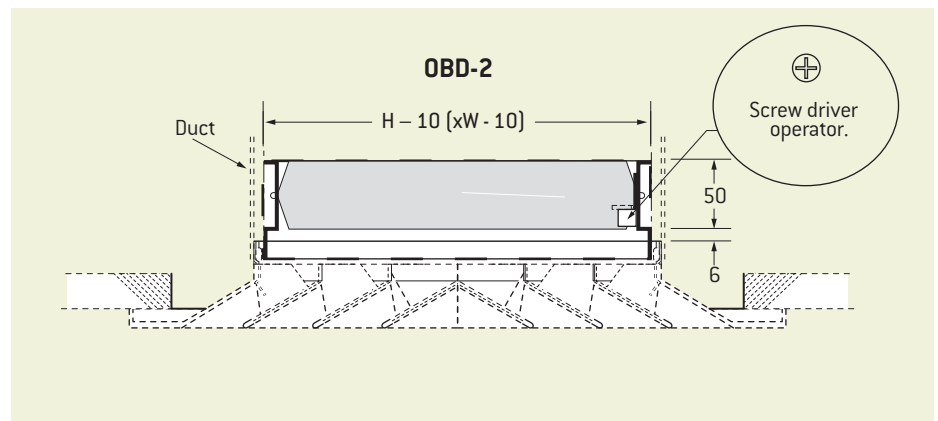
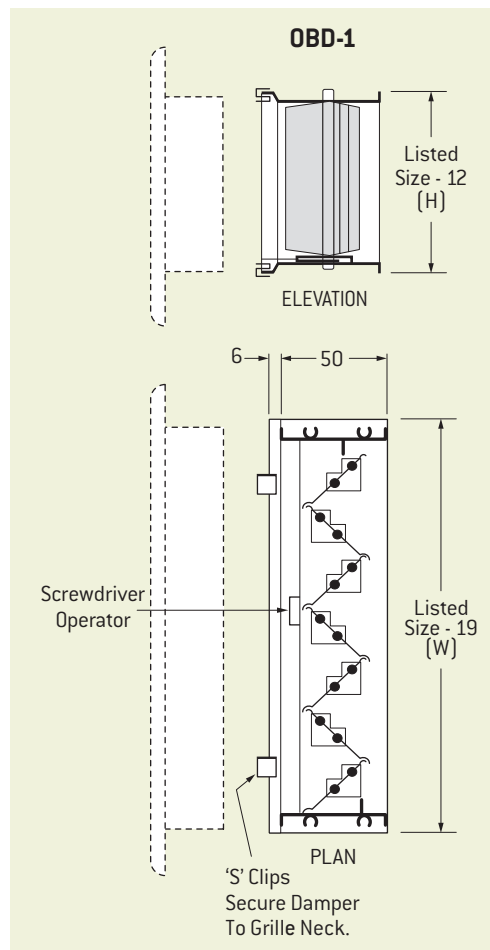

Due to a policy of continuous development and improvement the right is reserved to supply products which may differ slightly from those illustrated and described in this publication.

Sectorising Baffles/Throw Reducing Vanes – ACCESSORIES

Model: SB – Sectorising Baffles

Satin etch black on steel, standard 45° baffle for all round neck Holyoke diffusers.

Multi-directional performance from CRA and CSRV diffusers.

Use Model SB sectorising baffles to eliminate air and supply throw to any sector of throw radius, in 45° modules.

The primary air pattern of a model CSRD as defined by the 0.5m/s isovel shown above is obtained from a 250 diameter neck diffuser with a 600 square louvered face, handling 0.127m³/s. One quarter of the diffuser neck is blanked off by two adjacent SBs, making a three way throw.

Selection should take into account the reduction in distribution face area, by using the appropriate selection table for a full face diffuser, and multiplying actual air delivery by the inverse of the true free area proportion e.g. for this example, select on CSRD data (page 180D), using $4/3 \times 0.127\text{m}^3/\text{s} = 0.169\text{m}^3/\text{s}$. This gives a throw at VT of 0.5m/s, of 2.0 m, & NC 33.

Note: Weights subject to neck size and configuration, contact your local Holyoke branch.

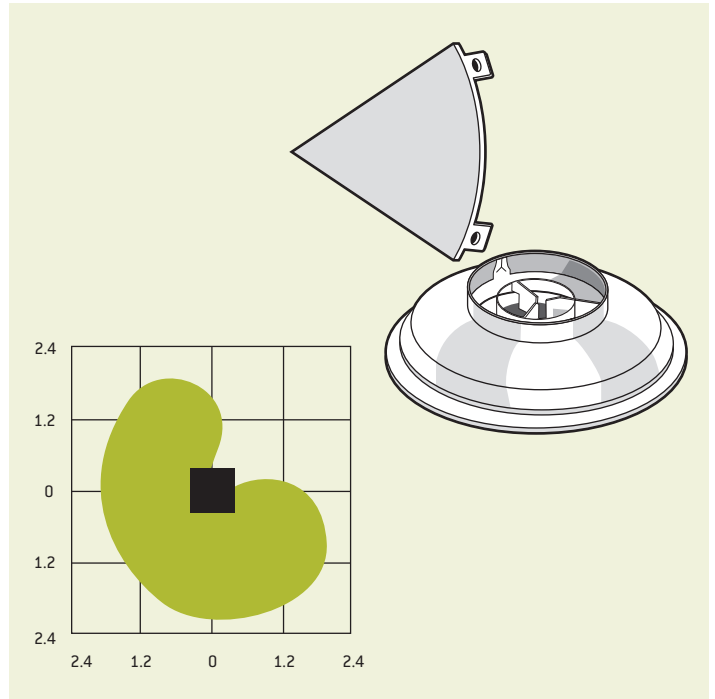

Model: TRV – Throw Reducing Vanes

Throw reducing vanes increase the selection flexibility of the CMP range.

They are also a convenient device for overcoming drafts created by obstacles placed in an air stream after installation. Each vane is formed from sheet aluminium, and takes the shape of two sides of a triangular pyramid, 38 mm long, so that it neatly clips into the space between adjacent wings of the diffuser.

It functions by dividing a single air stream into two smaller divergent streams, in the same way as divergent throw is created by the vertical blades on a side wall grille. Vanes are supplied in “sticks”, from which the required number can be easily broken away, and installation is usually done in sets of more than one vane.

A set of four vanes will clip correctly into four wing spacers - see illustration.

The diagrams adjacent show the 1.0 m/s isovel reduced by 40% when using TRV's on a model CMP 225 x 225 with different core styles.

The number and location of TRV's required per side of the diffuser are shown in the table below. When installed in accordance with this:

1. Throw reduction will be as shown in the isovel diagrams.
2. Total pressure requirements will be 1.40 times that listed in performance tables.
3. Noise level will be 4 NC higher than the listed figure.

Note: Standard 1200 mm length 0.21 Kg.

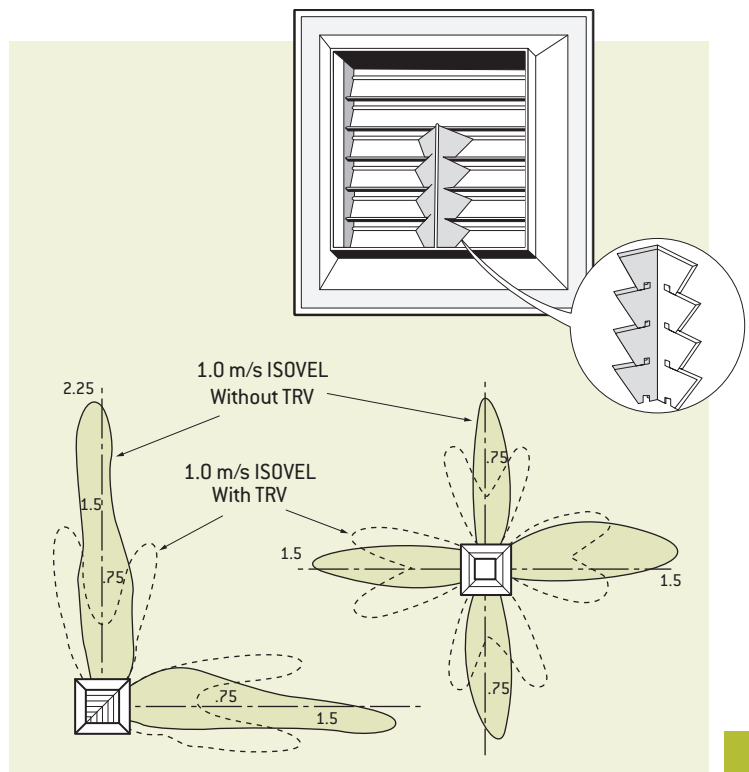

Table for Selection of Throw Reducing Vanes											
X →	75	150	225	300	375	450	525	600	675	750	1200
	1	1 1/2	2 1/2	3	4	5	5	6	7	8	11
	2	2	3	4	4	5	7	7	8	10	14
	3	4	5	7	8	9	11	12	13	16	22

ACCESSORIES – Radial & Butterfly Dampers/Equalising Grids

Model: RD – Radial Balancing Damper

The 'RD – Radial Balancing Damper' is a specially designed product for fixed volume control in round diffuser installations and balancing applications mounted in 'Cushion Head Box' circular entry spigots.

Continually adjustable from fully open to fully closed, via a central square drive operated mechanism. 4 models are available to suit the nominal duct sizes shown.

Constructed from galvanised mild steel, with a UV stabilised and fire rated polymer drive pinion. Optional driver and cable available.

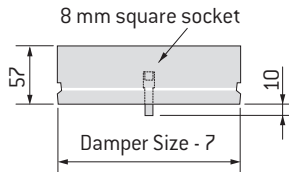

Product Ref	Nominal Duct Size	Actual Size	Approximate Weight Kg
RD 150	150	143	0.33
RD 200	200	193	0.63
RD 250	250	243	0.99
RD 300	300	293	1.42

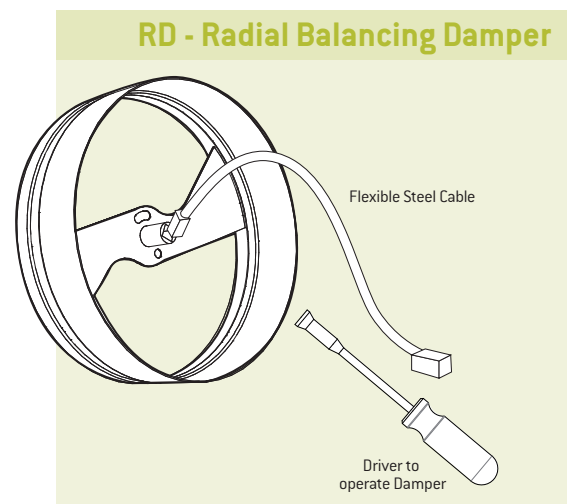

Models: EGS and EGL – Equalising Grid

32 mm extruded aluminium aerofoil blades in an extruded aluminium frame. Blades can be individually set to obtain equalised or desired flow over the neck of a diffuser or sidewall grille. Stainless steel friction wire interlaced on axles holds the required setting. Bright zinc plated 'S' clips fix grid to neck of diffuser or grille. Also available with joggle strip for duct mounting.

MODEL EGS - Square, or with blades running in short direction.*

MODEL EGL - Blades parallel to long dimension.*

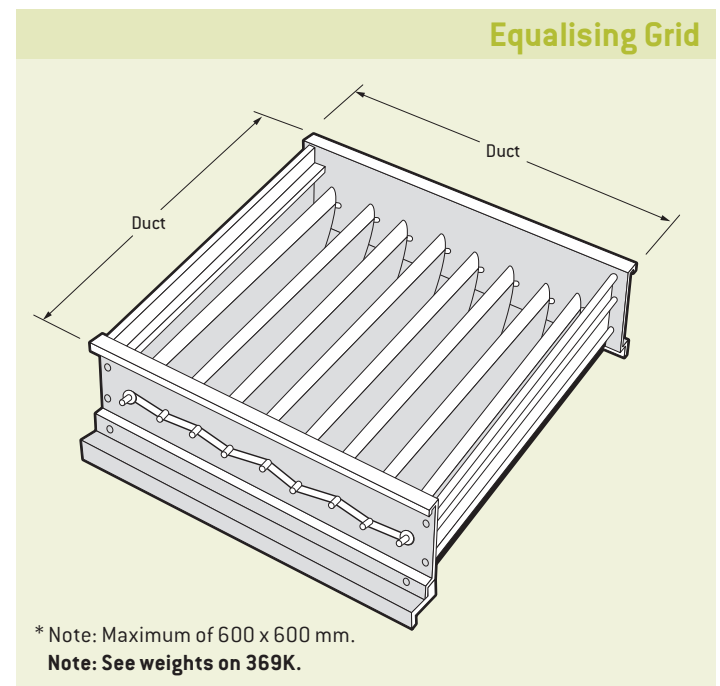
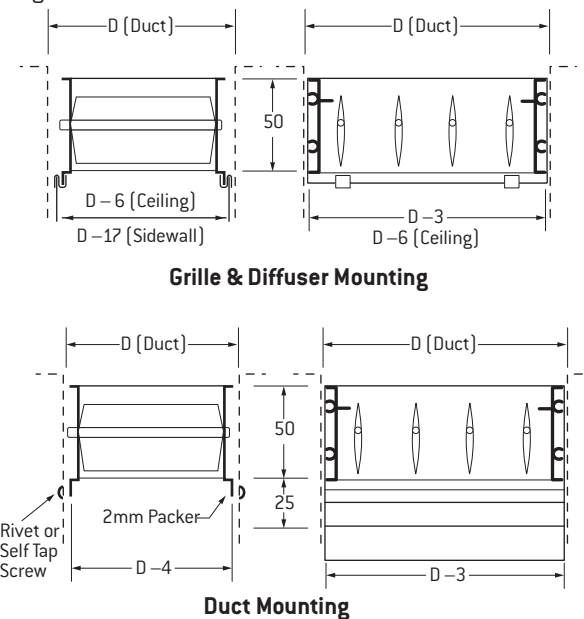

* Note: Maximum of 600 x 600 mm.
Note: See weights on 369K.

Round Duct Balancing Dampers – SP & SPM

Model: SP – Round Duct Damper with Manual Operator

Material:

Case: 0.55 mm Galvanised Mild Steel.

Blade: 0.75 mm Galvanised Mild Steel.

Bearings: Galvanised Steel Pins.

A robust, in-line, round duct balancing damper, with single disc blade and manual quadrant, with locking wing nut. Complete with crimped ends for ease of fitment within spiral ducting.

Typical utilised for low velocity, low pressure branch take-offs.
Install with blade horizontal.

Note: Not suitable for 'Shut Off' applications, (refer to section H, HCD product).

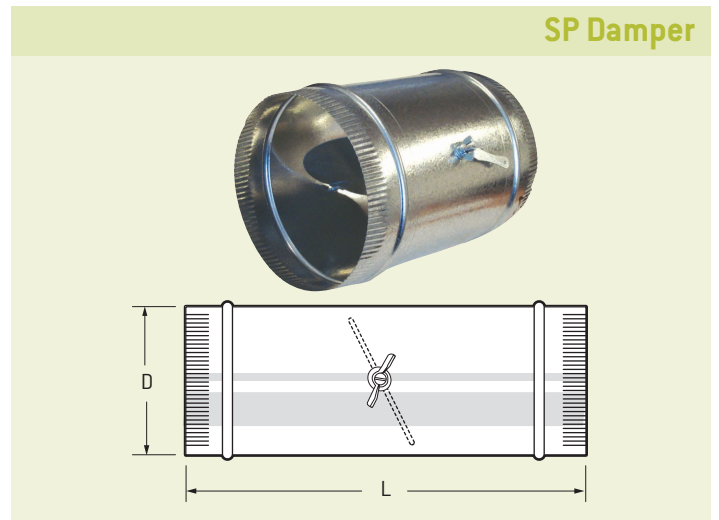

Guide Product Weights	
Size	Approximate Weight in Kg.
200 x 200	0.40
200 x 300	0.60
300 x 600	1.60
Size	EGL
300 x 200	0.60
400 x 200	0.80
600 x 200	1.20

Size 'D' Diameter	Size 'L' Length	Approximate Weight Kg
100	230	0.43
125	230	0.54
150	230	0.66
175	230	0.78
200	250	1.00
225	275	1.20
250	300	1.45
275	325	1.72
300	350	2.02
350	400	2.69

Model: SPM – Round Duct Damper with Hexagon Shaft for Motorised Operation

Material:

Case: 0.75 mm Galvanised Mild Steel.

Blade: 2 layers 0.75 mm Galvanised Mild Steel.

Bearings: 2 Piece Acetal.

Shaft: Aluminium Hexagon, 100 mm.

A robust, in-line, round duct balancing damper, suitable for motorised operation, complete with a sturdy double skin, single disc blade and extended shaft, to allow for insulation, (by others), when mounting the actuator.

Typically utilised for balancing of low or medium velocity and pressure, spiral duct.

Install with blade horizontal.

Notes

1. Not suitable for 'Shut Off' applications, (refer to section H, HCD product).

2. SPM damper length extended by 100 mm, for spring return applications.

3. A complete range of Rigid, Semi-Rigid and Flexible ducting is available, refer to Section J.

Size 'D' Diameter	Size 'L' Length	Approximate Weight Kg
100	300	0.56
125	300	0.77
150	300	0.94
175	300	1.08
200	300	1.31
225	300	1.51
250	300	1.74
275	325	2.06
300	350	2.44
350	400	3.27

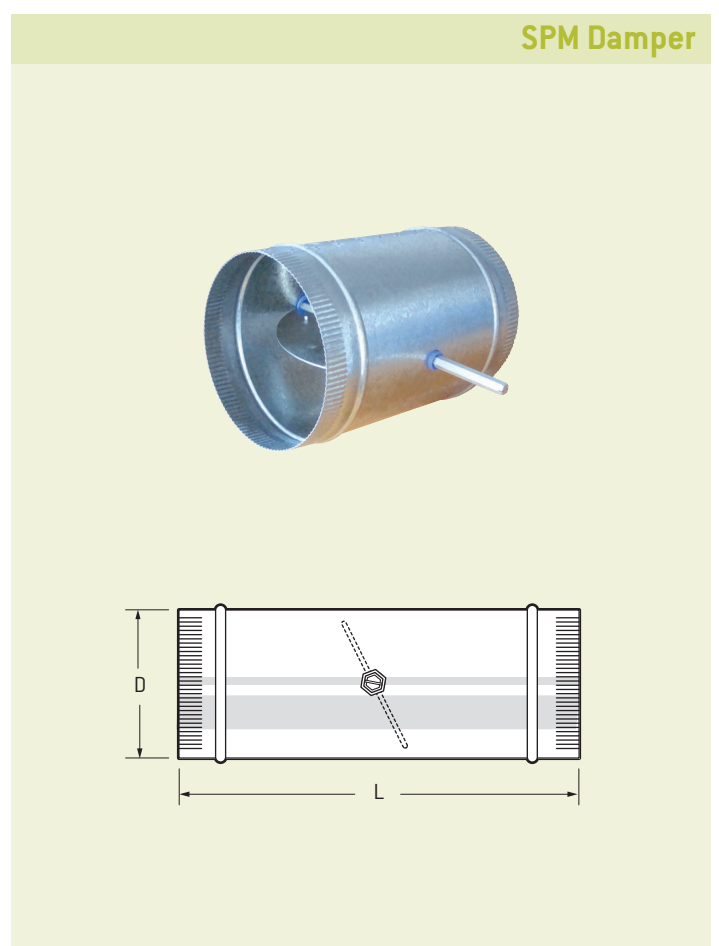

ACCESSORIES – Stainless Steel Vent

Model: SSV – 316 Stainless Steel Vent

External ventilation cowl suitable for exhaust systems in a variety of applications. Includes a built in backdraft damper to prevent reverse flow and insect mesh. Constructed from 316 stainless steel.

Variations:

Back draft damper can be removed for supply air applications.
Insect mesh can be removed if required.

Available sizes - 100, 150, 200

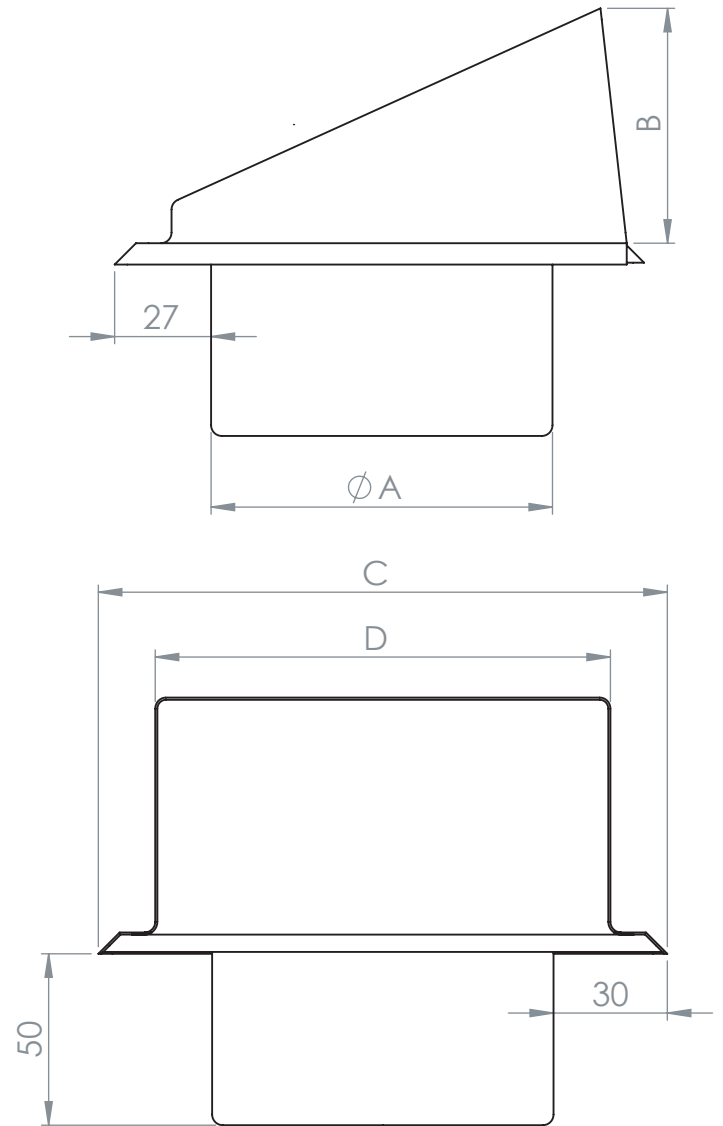
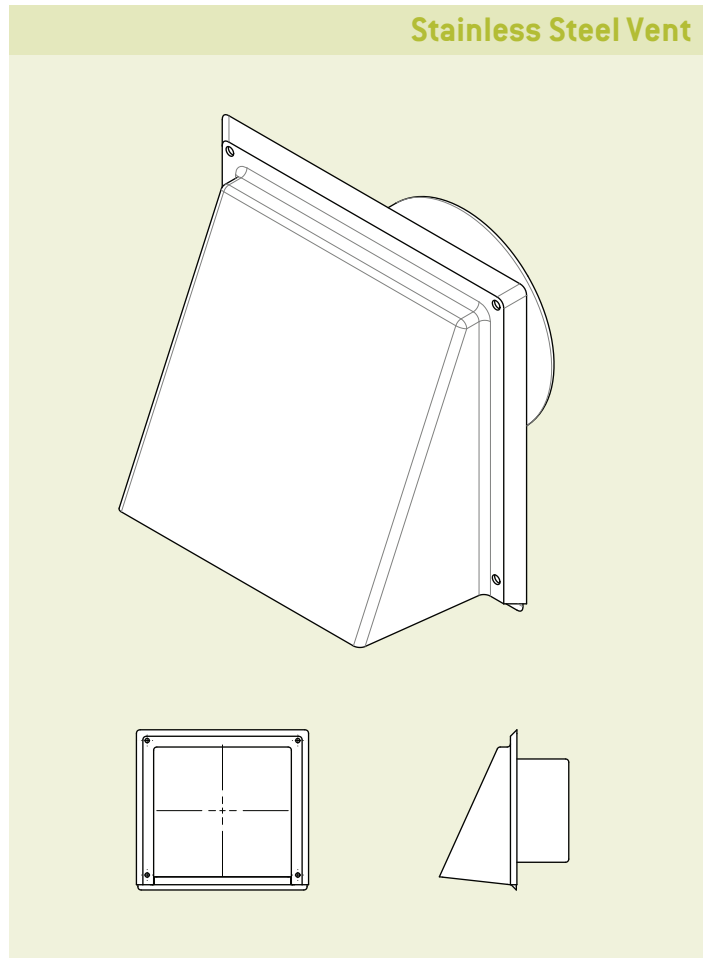

Stainless Steel Vent				
Diameter	A	B	C	D
100	95	70	160	125
150	145	100	205	175
200	195	135	255	225

All dimensions are in mm.

Stainless Steel Vent

Pressure Drop (Pa)	Flowrate (l/s)	10	20	25	30	40	50	60	70	75	80	90	100	110	120	125	130	140	150	
	SSV 100	17	24	27	31	41	57	77	100	112										
	SSV 150	6	10	12	14	18	23	28	34	37	41	48	57							
	SSV 200	3	8	10	11	13	15	17	19	20	22	24	27	31	34	36	39	43	49	

Stainless Steel Vent - No Mesh

Pressure Drop (Pa)	Flowrate (l/s)	10	20	25	30	40	50	60	70	75	80	90	100	110	120	125	130	140	150	
	SSV 100	15	22	24	26	32	43	58	77	87										
	SSV 150	6	9	11	12	14	17	20	23	25	28	33	40							
	SSV 200	3	8	9	10	12	14	15	17	17	18	19	21	23	25	27	28	31	35	

Round Backdraft Damper/Duct Hangers – ACCESSORIES

Model: RBD – Round Backdraft Damper

Round backdraft damper suitable for lower pressure systems. Construction consists of a galvanised duct with aluminium backdraft damper blades.

Available sizes - 150, 200

Round Backdraft Damper

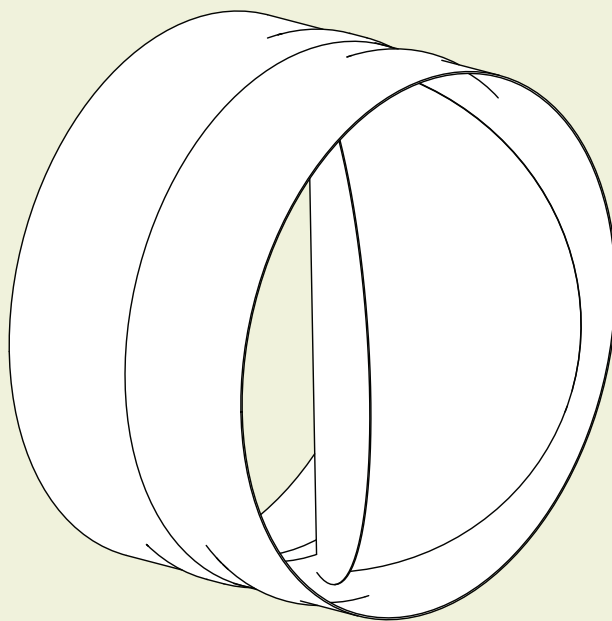

Model: DH – Duct Hangers

Duct hangers are the perfect solution to replace substandard hanging products. Plastic strapping, cable ties and other frequently used products can restrict flexible duct and damage the outer jacket. This impedes airflow and performance and therefore increasing running costs.

Features:

- In accordance with Australian Standard 4254.1 - 2012
- The Holyoake strap is tested to hold up 30 Kg
- Designed to fit up to 4000 ducting
- One duct hanger kit pack includes 10 plastic hangers with 30m roll of high strength nylon strapping
- Extra wide 135mm support hanger (beware of narrow hangers)
- UV Stable

Duct Hangers

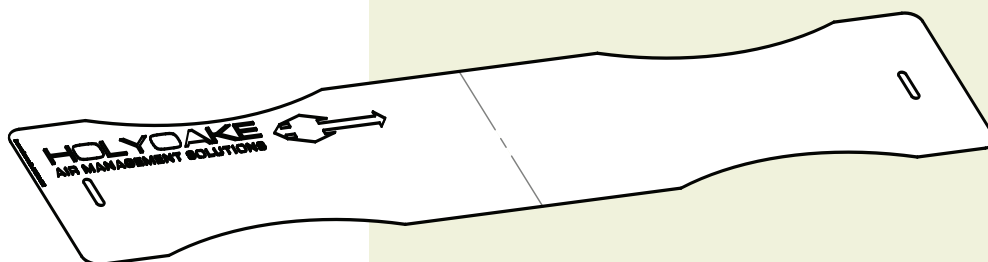

ACCESSORIES – Luftec Actuators

Model: Luftec Actuators

Holyoake stock a vast range of Luftec branded actuators. These are cost effective actuators suitable for a variety of heating ventilation and air-conditioning applications (HVAC). See the tables on the following page for the different ranges of actuators and options.

The actuators are compliant to the European Union's CE, the US UL and the French BV certifications. The Company has also fully implemented ISO9001-2015 (CQC) international quality management system.

Contact your local Holyoake branch for full Luftec model details and relevant datasheets.



General damper actuators

LUFTEC CODE	Torque	Control Type	Voltage	Auxiliary Switches
LFT(TORQUE).M24.D	2, 4, 6, 8, 16, 24, 32 Nm	ON/OFF 2/3 Points	24V AC/DC	NONE
LFT(TORQUE).M24.DS				1/2 - SPDT
LFT(TORQUE).M230.D			100-240VAC	NONE
LFT(TORQUE).M230.DS				1/2 - SPDT
LFT(TORQUE).M24.A		Modulating 0(2) - 10V 0(4) - 20mA	24V AC/DC	NONE
LFT(TORQUE).M24.AS				1/2 - SPDT
LFT(TORQUE).M230.A			100-240VAC	NONE
LFT(TORQUE).M230.AS				1/2 - SPDT

Fast running damper actuator

LUFTEC CODE	Torque	Control Type	Voltage	Auxiliary Switches
LFT(TORQUE).MQ24.D	8, 16 Nm	ON/OFF 2/3 Points	24V AC/DC	NONE
LFT(TORQUE).MQ24.DS				2 - SPDT
LFT(TORQUE).MQ230.D			100-240VAC	NONE
LFT(TORQUE).MQ230.DS				2 - SPDT
LFT(TORQUE).MQ24.A		Modulating 0(2) - 10V 0(4) - 20mA	24V AC/DC	NONE
LFT(TORQUE).MQ24.AS				2 - SPDT
LFT(TORQUE).MQ230.A			100-240VAC	NONE
LFT(TORQUE).MQ230.AS				2 - SPDT

Damper actuator with spring return

LUFTEC CODE	Torque	Control Type	Voltage	Auxiliary Switches
LFT(TORQUE).SR24.D	5, 8, 15, 20 Nm	ON/OFF 2/3 Points	24V AC/DC	NONE
LFT(TORQUE).SR24.DS				2 - SPDT
LFT(TORQUE).SR230.D			100-240VAC	NONE
LFT(TORQUE).SR230.DS				2 - SPDT

Fire and Smoke damper actuator - fast running with spring return

Complies with AS 1682 speed requirements

LUFTEC CODE	Torque	Control Type	Voltage	Auxiliary Switches
LFT(TORQUE).SRQ24.D	5 Nm	ON/OFF 2/3 Points	24V AC/DC	NONE
LFT(TORQUE).SRQ24.DS				2 - SPDT
LFT(TORQUE).SRQ24.DST				2 - SPDT
LFT(TORQUE).SRQ230.D			100-240VAC	NONE
LFT(TORQUE).SRQ230.DS				2 - SPDT
LFT(TORQUE).SRQ230.DST				2 - SPDT

Note: Model DST with thermal sensor included

ACCESSORIES – Turning Vane/Self Aligning Bends

Models: TVS and TVL – Turning Vane

Extruded aluminium curved blades in an extruded aluminium frame. Blades individually adjustable to the desired angle, directing air through 90° on to neck of ceiling diffuser or into short collar for side wall registers and grilles.

Frame is hinged at one end for riveting to duct, and provided with pre punched strip at the other, to fix the frame to the required angle. Blades are held in place with stainless steel friction wire.

MODEL TVS - Square or with blades running in short direction.*

MODEL TVL - Blades parallel to long dimension.*

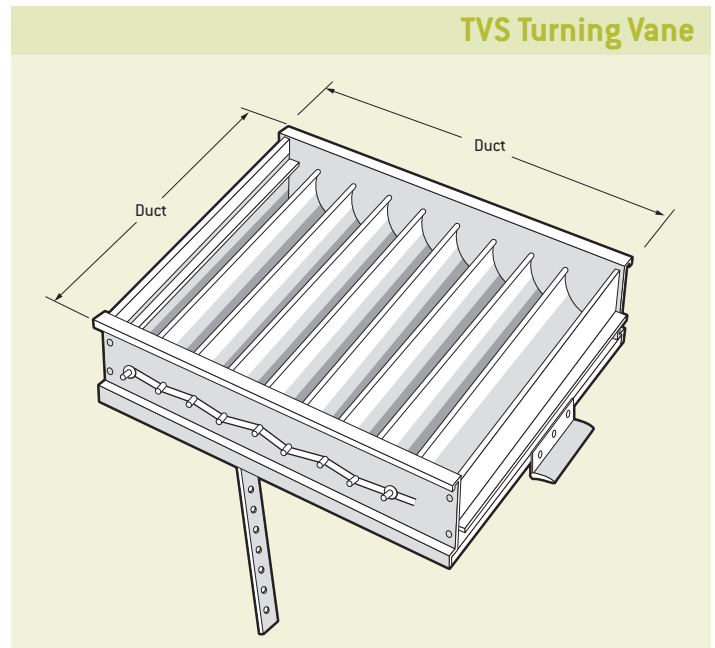
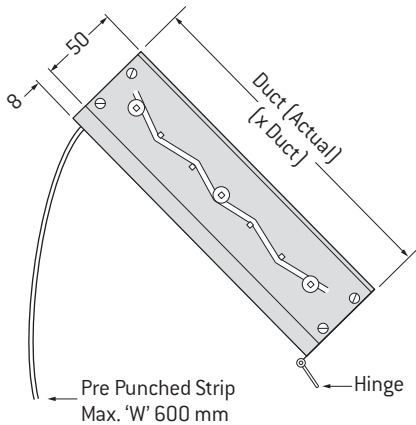

* Note: Maximum of 600 x 600 mm.

Guide Product Weights	
Size	Approximate Weight in Kg.
200 x 200	0.60
200 x 300	0.80
300 x 600	1.80
Size	TVL
300 x 200	0.80
400 x 200	1.00
600 x 200	1.40

Model: SAB – Self Aligning Bend

For use with rigid round Spiroloc duct. Each bend consists of four segments which can be independently twisted with respect to the adjacent segment, giving either offset or any angle from 90° to 180°.

Holyoake SAB's are crimped on both ends to insert into standard Spiroloc.

Material:

Galvanised Steel: 0.55 mm

Galvanised bends are primarily intended for use on low pressure systems, where joints should be sealed with duct tape, once the angle is set.

Stainless Steel SAB's are also available to special order.

SAB Standard Diameters Available, mm										R,mm
100	125	150	175	200	225	250	300	350	400	45*
0.25	0.50	0.54	0.90	1.17	1.28	1.58	1.95	2.55	3.46	Kg*
450	500	550	600	* Approximate						77*
5.93	7.36	8.90	10.60							Kg*

Due to a policy of continuous development and improvement the right is reserved to supply products which may differ slightly from those illustrated and described in this publication.

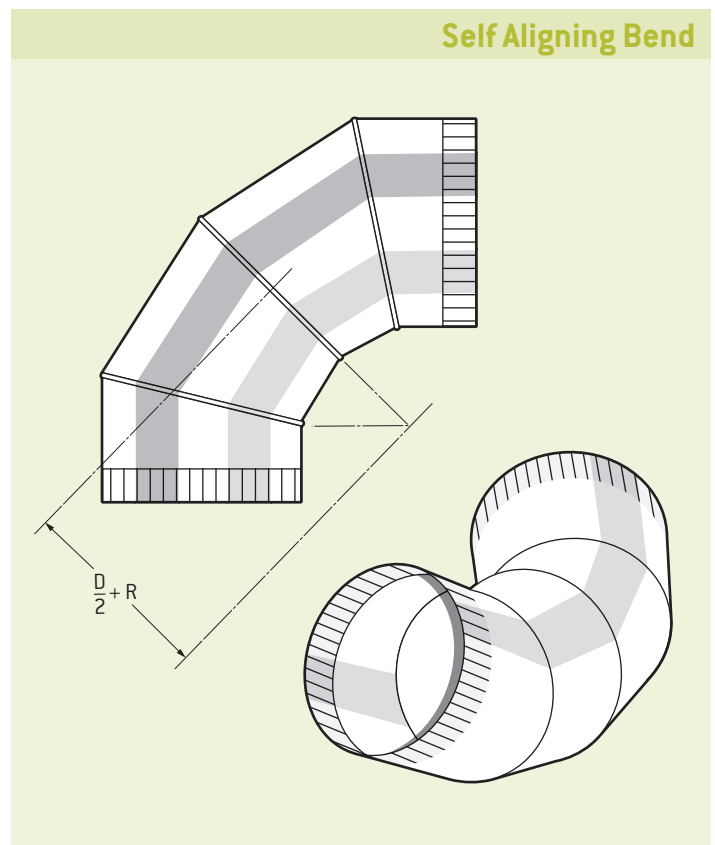

Air Scoop/Stream Splitter Damper – ACCESSORIES

Model: AS50 and AS25 – Air Scoop

Gang operated parallel blades set at 25 or 50 mm pitch, maintain correct turning angle for 90° branch take-offs and for full travel of scoop, providing even air distribution along branch duct or across supply grille face.

Where used in long or inaccessible branch ducts, an access door should be installed to facilitate adjustment. Hinged, pre-punched strip retains required setting - rivet or screw to duct.

Installer to provide supporting foot if D exceeds 300 mm or bottoms of main and branch ducts are not on same plane. If top and bottom of main and branch ducts are not in same plane, branch duct extensions above and below extractor will improve performance.

Maximum Size: 900 x 300, 300 x 900 or 600 x 600.

Model AS50L & 25L: Blades parallel to long dimension.

Model AS50S & 25S: Blades parallel to short dimension.

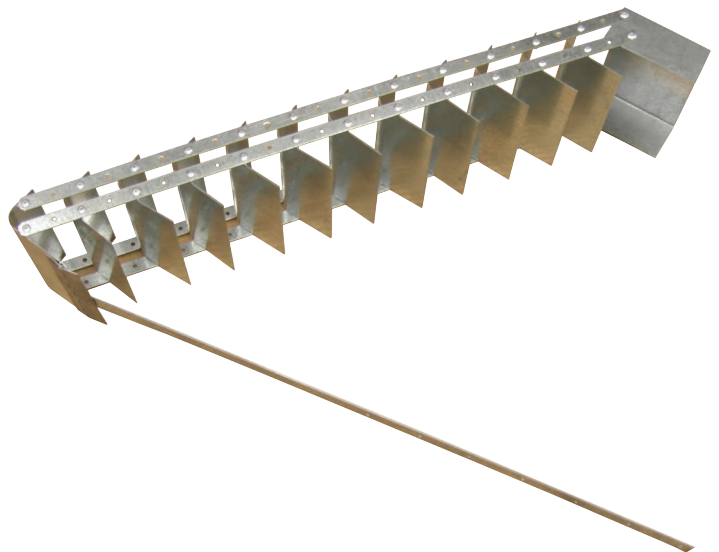
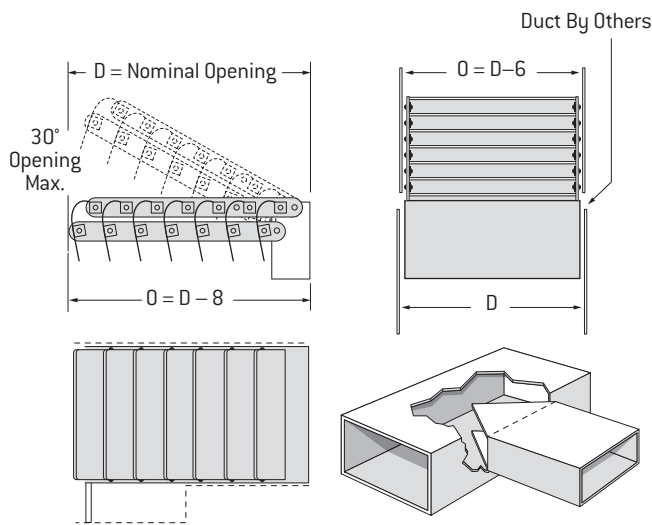
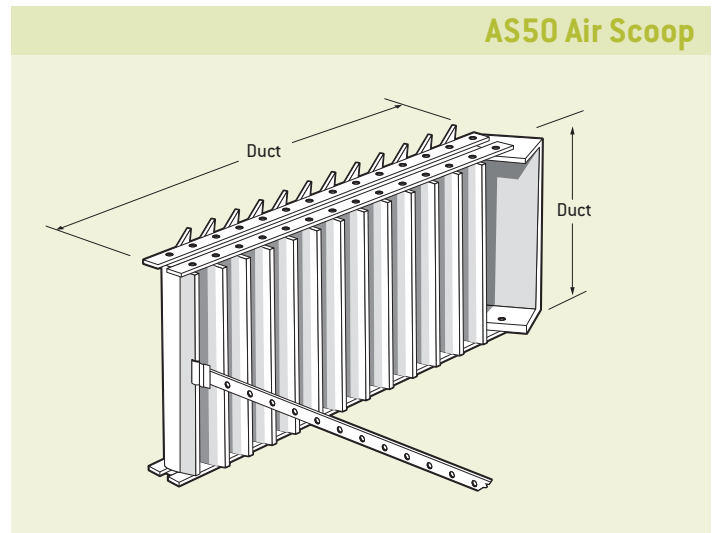

Model: SSD – Stream Splitter Damper

The air scooping action of the gang operated curve blades control air volume and direction.

These dampers can be mounted directly on the neck of the outlet where it protrudes into the air stream, or can be fitted at the take-off from the main duct to control volume and direction into the branch, provided access is available to screw adjustment. Stream splitter damper with adjuster through grille face. Manufactured from zinc coated steel.

Maximum Size: 900 x 300, 300 x 900 or 600 x 600 mm.

SSD 25L or 50L: Blades parallel to long dimension.

SSD 25S or 50S: Blades parallel to short dimension.

Finish: Matt black.

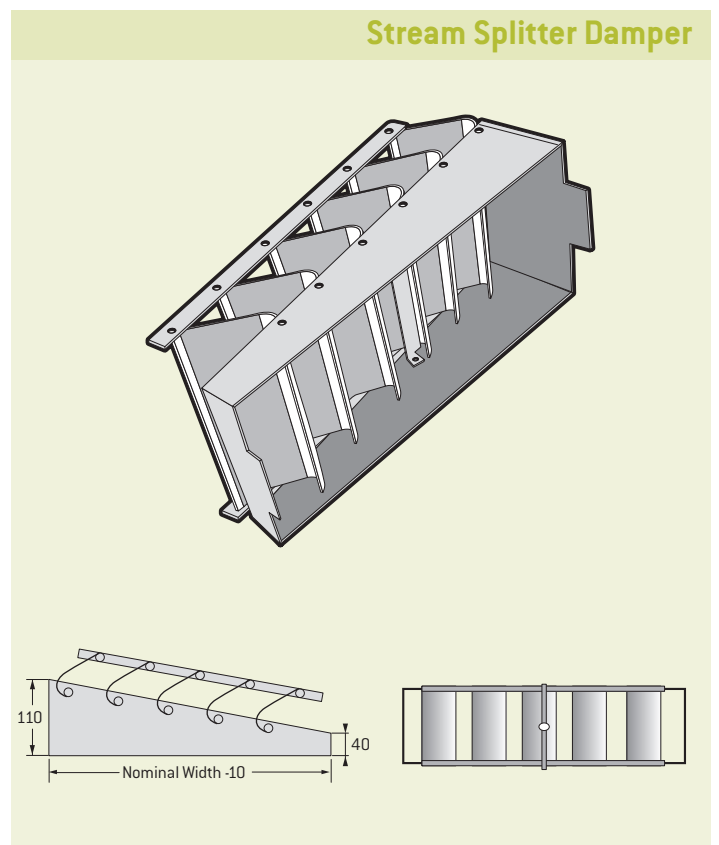

Guide Product Weights				
Approximate Weight in Kg.				
Size	AS 25 L	AS 50 L	AS 25 S	AS 50 S
900 x 300	6.00	4.52		
300 x 900			5.20	3.85
Size	SSD 25 L	SSD 50 L	SSD 25 S	SSD 50 S
600 x 300	4.20	3.20		
900 x 300	6.20	4.72		
300 x 600			4.80	3.60
300 x 900			5.40	4.05

ACCESSORIES – Cushion Head/Duct Tape

Model: CH – Cushion Head

Adapts square neck diffusers and return grilles to a side entry round flexible, semi rigid, or rigid duct. Can be supplied plain or with a black polyester insulation.

Material: 0.55 Galvanised Steel

Insulation Options: 14, 25 or 50 mm

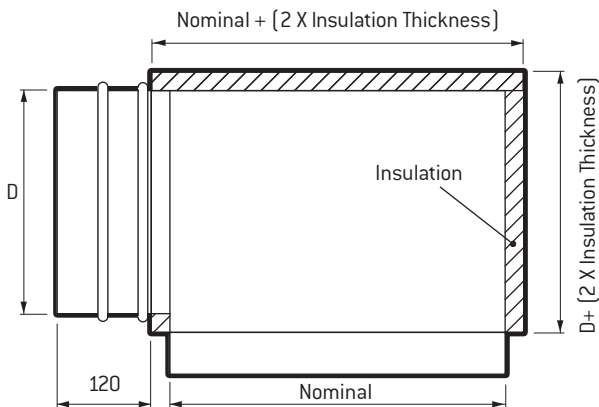

Cushion Head Box

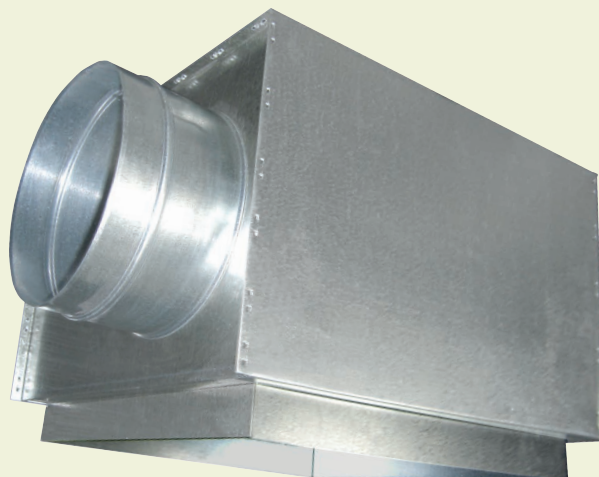

Guide Product Weights

Approximate Weight in Kg.

Size	Inc 25 mm Insulation	Size	Inc 25 mm Insulation
CRS 300	4.00	225 SQ CH	2.50
CRS 450	6.50	300 SQ CH	4.00
CSS 450	6.50	375 SQ CH	5.00
CSS 600	6.50	450 SQ CH	6.50
595 SQ T Rail	6.50	595 SQ CH	6.50
CSSR Plenum 615 Diameter			3.20

Ordering Code Examples and Suggested Specification

CH	-	CRS CSS CFP CFPP	-	P I	-	14 25 50	-	150 200 250	-	W x H
Cushion Head.		Product Type.		Plain, or Insulated.		Insulation Thickness.		Duct Connection Inlet Size.		Nominal Diffuser, or Grille Neck Size.

Holyoake Cushion Head boxes shall be constructed from galvanised steel and be complete with suitably sized galvanised steel connection spigots and accessories, as appropriate. Optional black polyester insulation, 14, 25, or 50 mm thick can be incorporated.

All as manufactured by Holyoake.

Note: Refer to page 386K for Premi-aire Cushion Heads boxes.

Model: DUCT TAPE

A Premium Grade Polyethylene coated cloth duct tape with a high tack rubber adhesive system.

Colour: Silver

Width: 48 mm

Roll Length: 55 m

Features:

- Conforms easily to difficult shapes.
- Strong permanent bond.
- High Tensile (and tearing) strength.
- Will not curl.

Duct Tape is primarily intended for sealing H.V.A.C. duct joints* and for wrapping insulated pipes as a vapour barrier and as protection against impact and other damage. It is also used in packaging where a strong moisture barrier is required.

Available as single, or multiple rolls, or cartons of 24.

Approximate weight 0.91 Kg per roll, 24 Kg per box.

*** You should also use duct ties or a mechanical fixing as per AS 4254.1 - 2012 (refer to pages 357J, 360J and 385K).**

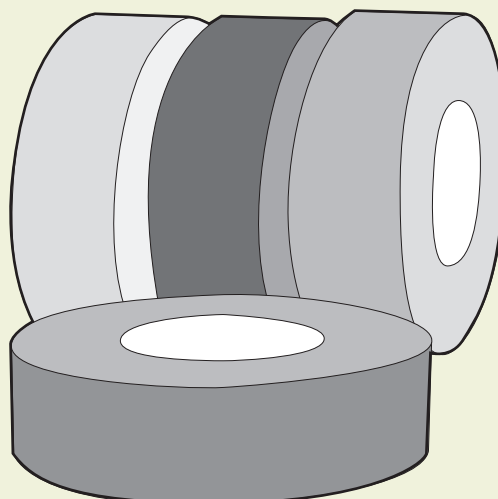

Model: SRA – Square to Round Adaptor

Material: 0.55 mm Galvanised Steel.

Adapts square neck CMP diffusers and return grilles such as HI-35, or EC-125 to round flexible, semi rigid, or rigid duct.

Suitable for use with OBD-1, 2 or S, RD, or BD-85 control dampers.

Neck is standard spin collar unless specially ordered otherwise.

Guide Product Weights	
Approximate Weight in Kg.	
Size	SRA
600 x 600 x 300 Diameter	3.10
Size	RRA
600 x 300 x 200 Diameter	2.53
Size	SSA
600 SQ x 300 SQ	2.94

For other configurations contact your local branch for details.

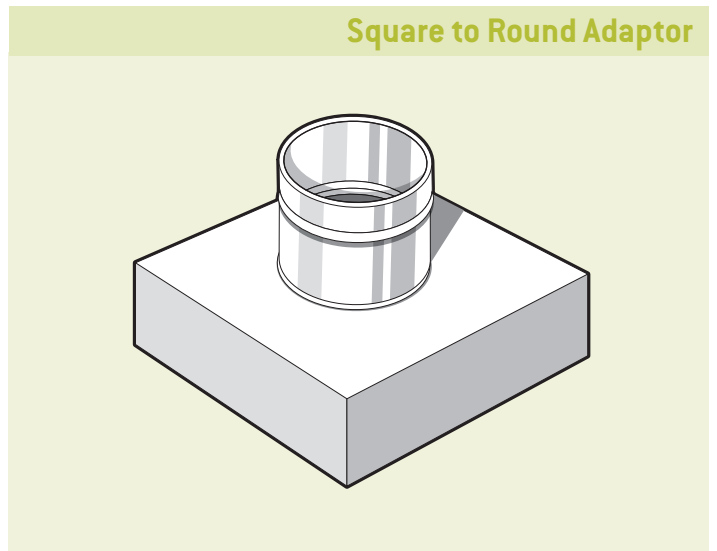

Model: RRA – Rectangular to Round Adaptor

Material: 0.55 mm Galvanised Steel.

Adapts rectangular diffusers and return grilles to round flexible, semi rigid, or rigid duct.

Suitable for use with OBD-1, 2 or S, RD, or BD-85 control dampers.

Neck is standard spin collar unless specially ordered otherwise.

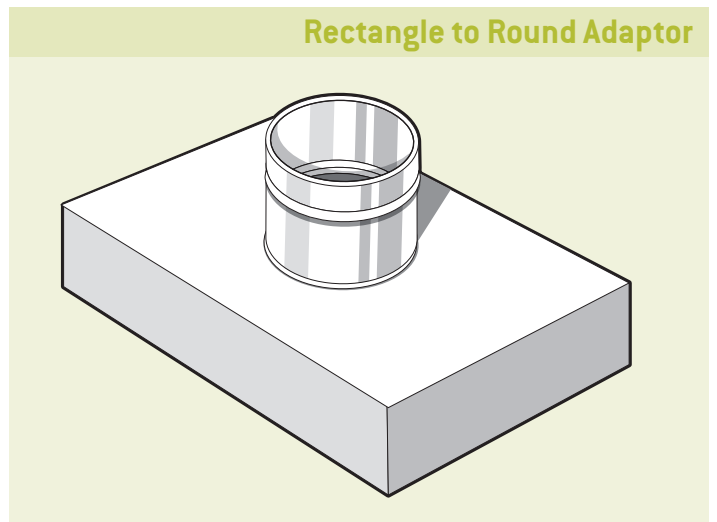

SRA/RRA Dimensional Details

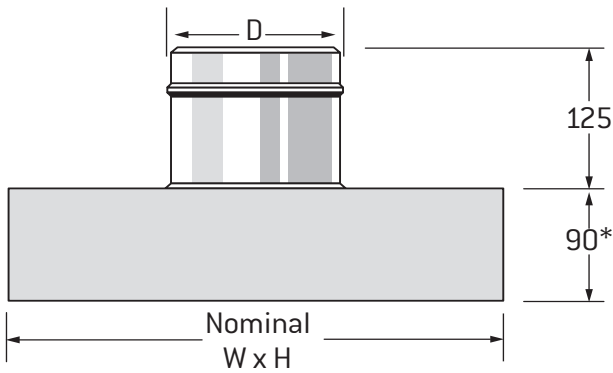

*Where OBD fitted. If no OBD fitted, height may be reduced to 25 mm.

For Use With:	Actual W x H mm x mm	Max. Neck Dia. 'D', mm
CMP	Wa = Nominal W Ha = Nominal H	Smaller of Wn or Hn - 15
EC-125, HI-35 RL-23, RL-25, RLH	Wa = Nominal - 15 Ha = Nominal - 15	Smaller of Wn or Hn - 30
For use with other products, contact your local Holyoake branch.		

Wn = Nominal Width
Hn = Nominal Height

Wa = Actual Width
Ha = Actual Height

Model: SSA – Square to Square Adaptor

Material: 0.55 mm Galvanised Steel.

Adapts square neck diffusers and return grilles to square ductwork.

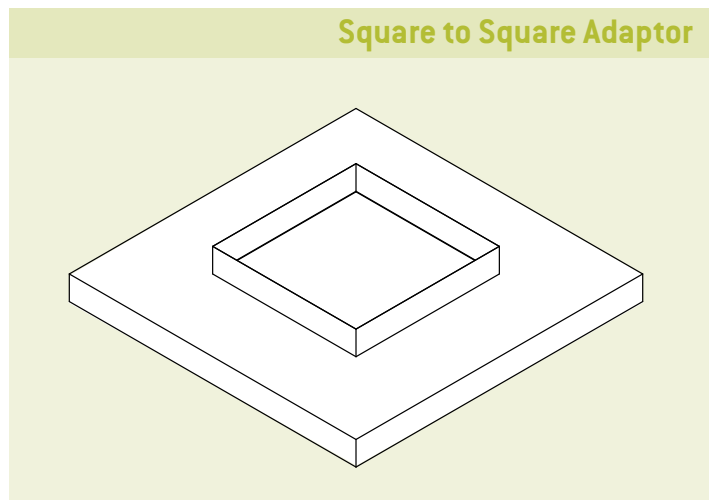
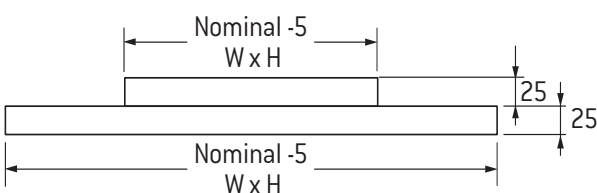

ACCESSORIES – Round Duct Connectors

Model: Spin-Connector for Spiroset & Spiroflex

Diameter 'D' suits Spiroflex or Spiroset standard sizes.

Material: 0.45 mm galvanised steel (sizes 100 - 250 mm).
0.55 mm galvanised steel (sizes 251 - 400 mm).

Model: Spin-Connector for Spiroloc

Diameter 'D' suits Spiroloc standard sizes.

Material: 0.45 mm galvanised steel (sizes 100 - 250 mm).
0.55 mm galvanised steel (sizes 251 - 400 mm).

Model: SPIN-COLLAR – Screw-in for Round Duct

Material: 0.45 mm galvanised steel (sizes 100 – 250 mm).
0.55 mm galvanised steel (sizes 251 - 400 mm).

Primarily for use as a screw-in from rectangular duct, or plenum for flexible, or semi rigid duct, can also be used for rigid round duct and can be supplied with single blade damper. Preformed with swage and lead-in edge, the spin-collar is based upon a roll-formed groove which neatly fits the edge of a hole, cut in sheet metal up to 1mm thick.

By cutting the hole to the correct diameter, using the table below, the spin-collar may be "wound in", starting at a 10 mm radial cut anywhere around the hole.

Non standard sizes are available to special order.

Hole Diameter $H = D - 4$ mm.

Minimum Diameter 100 mm.

Maximum Diameter 400 mm.

Spin Connector

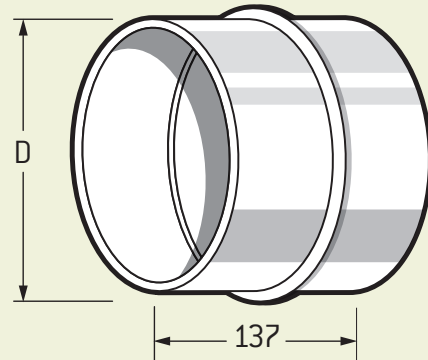

Spin Collar

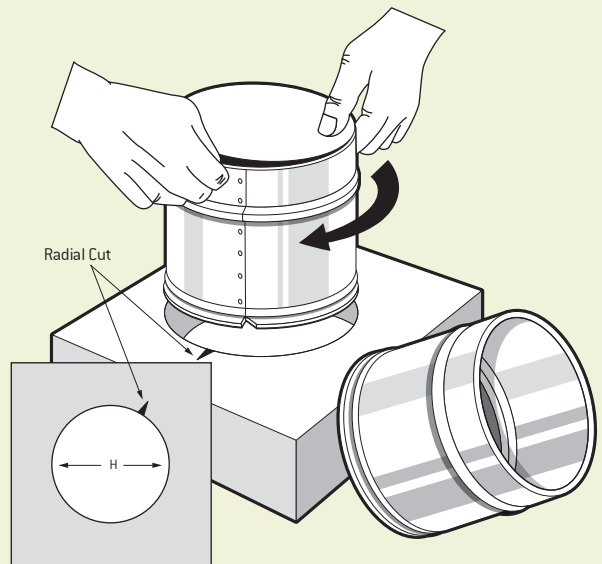

Exact size of hole in panel for correct fit

Spin Collar

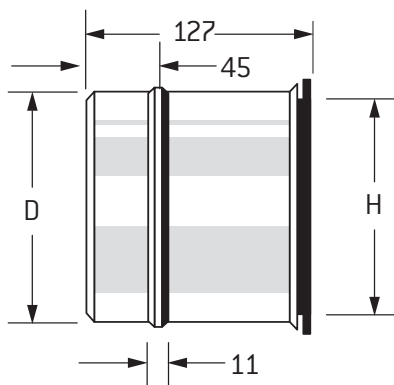

Standard Spiro Spin Collars			Guide Product Weights
Nominal Duct Dia mm	Collar Dia 'D' (OD) mm	Hole Diameter 'H' mm	Approximate Weight in Kg
			Spin-Con / Spin Col
100 Min	95	91	0.20
125	120	116	0.22
150	145	141	0.26
175	170	166	0.30
200	195	191	0.35
225	220	216	0.39
250	245	241	0.42
275	270	266	0.60
300	295	291	0.70
325	320	316	0.74
350	345	341	0.80
375	370	366	0.82
400 Max	395	391	0.87

Models: PDI, PDIA, FM-PDI, FM-PDIA – Flow Measuring Stations

The Holyoake PDI series flow measuring stations and sensors are inexpensive, but remarkably accurate pressure differential measuring devices. Because they sense an average of velocity pressures across the duct, they are very tolerant of poor inlet duct configurations and lose little of their straight duct accuracy of better than $\pm 5\%$. Each flow measuring station is furnished with a label showing the formula and factors for calculating velocity, from the pressure differential read on either a Magnahelic, or micromanometer. PDI sensors should be used in higher velocities such as those found in VAV terminal boxes. For normal duct velocities use the PDIA sensor.

Nominal Size	Internal Dia mm	Flow Factor 'K'		Guide Product Weights
		PDIA	PDI	Approximate Weight in Kg Both Styles
100	94	0.004	0.007	0.046
125	119	0.008	0.010	0.046
150	144	0.012	0.015	0.052
175	169	0.018	0.022	0.058
200	194	0.026	0.029	0.058
225	219	0.033	0.036	0.063
250	244	0.043	0.046	0.063
300	294	0.062	0.068	0.070
350	344	0.084	0.094	0.070
400	394	0.115	0.124	0.079

Notes

1. Flow Formula:

$$Q \text{ m}^3/\text{s} = K\sqrt{\Delta p} \text{ Pa (Air at 1.184 kg/m}^3, 21^\circ\text{C and 50\% RH)}$$

2. Both PDI and PDIA amplify the Δp signal. Amplification varies with size. For example, when compared with theoretical unamplified velocity pressure conversion, amplification factors are approximately:

SIZE	PDI	PDIA	These factors should not be used in calculation, but are shown to provide an indication of the amplifying effect of both types.
150	1.94	2.95	
300	1.67	1.98	

Model: DM-PDIA – Sensor

DM-PDIA assemblies are flange mounted sensors for insertion into rectangular duct. Measurement accuracy is much less definable due to the unknown velocity profile. However, where adequate straight duct (equivalent diameter x 10) exists, calculated velocity could be expected to lie within $\pm 5\%$ of actual, when using the formula:

$$V = K_v \sqrt{\Delta p} \text{ Pa}$$

Where V = velocity m/s and K_v = tabulated velocity factor.

Dimensions

SIZE	A	B	C	K_v
150	150	100	120	0.8525
200	210	160	185	0.9475
250	250	200	230	0.9780

Note: For weight details contact your local Holyoake branch.

Flow Measuring Station

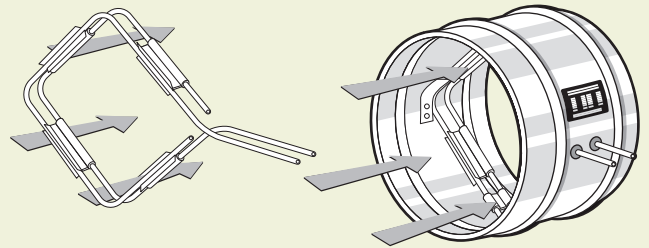

Model PDIA Sensor

Model FM-PDIA Station

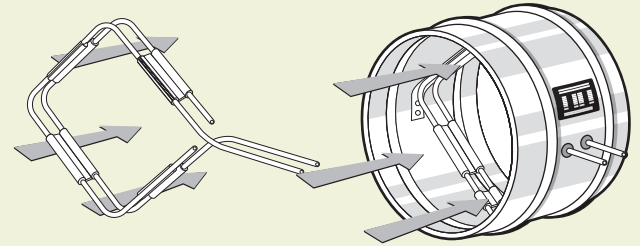

Model PDI Sensor

Model FM-PDI Station



Flow Direction

All PDIA Models

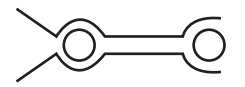

Velocity Static

Measuring Positions



Flow Direction

(Either Way)

All PDI Models

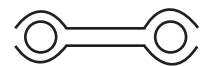

Velocity or Static

Measuring Positions
(Dependant on Flow Direction)

Duct Mounted PDIA

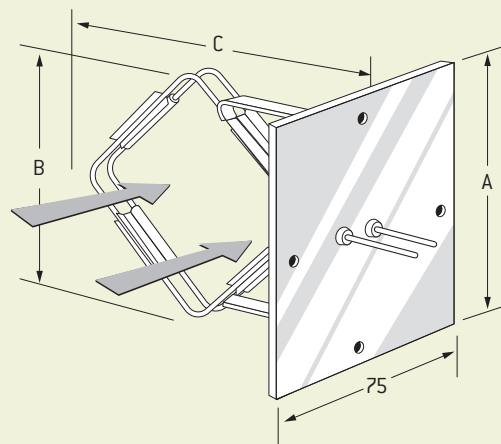

ACCESSORIES – PDI Sensor Flow Rates

k fact	0.007	0.010	0.015	0.022	0.029	0.036	0.046	0.068	0.094	0.124	
nom DIA	100	125	150	175	200	225	250	300	350	400	
exact ID	94	119	144	169	194	219	244	294	344	394	
Pa	m ³ /s	m ³ /s	m ³ /s	m ³ /s	m ³ /s	m ³ /s	m ³ /s	m ³ /s	m ³ /s	m ³ /s	inch wg
5	0.016	0.022	0.034	0.049	0.065	0.080	0.103	0.152	0.210	0.277	0.02
10	0.022	0.032	0.047	0.070	0.092	0.114	0.145	0.215	0.297	0.392	0.04
15	0.027	0.039	0.058	0.085	0.112	0.139	0.178	0.263	0.364	0.480	0.06
20	0.031	0.045	0.067	0.098	0.130	0.161	0.206	0.304	0.420	0.555	0.08
25	0.035	0.050	0.075	0.110	0.145	0.180	0.230	0.340	0.470	0.620	0.10
30	0.038	0.055	0.082	0.120	0.159	0.197	0.252	0.372	0.515	0.679	0.12
35	0.041	0.059	0.089	0.130	0.172	0.213	0.272	0.402	0.556	0.734	0.14
40	0.044	0.063	0.095	0.139	0.183	0.228	0.291	0.430	0.595	0.784	0.16
45	0.047	0.067	0.101	0.148	0.195	0.241	0.309	0.456	0.631	0.832	0.18
50	0.049	0.071	0.106	0.156	0.205	0.255	0.325	0.481	0.665	0.877	0.20
55	0.052	0.074	0.111	0.163	0.215	0.267	0.341	0.504	0.697	0.920	0.22
60	0.054	0.077	0.116	0.170	0.225	0.279	0.356	0.527	0.728	0.960	0.24
65	0.056	0.081	0.121	0.177	0.234	0.290	0.371	0.548	0.758	1.000	0.26
70	0.059	0.084	0.125	0.184	0.243	0.301	0.385	0.569	0.786	1.037	0.28
75	0.061	0.087	0.130	0.191	0.251	0.312	0.398	0.589	0.814	1.074	0.30
80	0.063	0.089	0.134	0.197	0.259	0.322	0.411	0.608	0.841	1.109	0.32
85	0.065	0.092	0.138	0.203	0.267	0.332	0.424	0.627	0.867	1.143	0.34
90	0.066	0.095	0.142	0.209	0.275	0.342	0.436	0.645	0.892	1.176	0.36
95	0.068	0.097	0.146	0.214	0.283	0.351	0.448	0.663	0.916	1.209	0.38
100	0.070	0.100	0.150	0.220	0.290	0.360	0.460	0.680	0.940	1.240	0.40
105	0.072	0.102	0.154	0.225	0.297	0.369	0.471	0.697	0.963	1.271	0.42
110	0.073	0.105	0.157	0.231	0.304	0.378	0.482	0.713	0.986	1.301	0.44
115	0.075	0.107	0.161	0.236	0.311	0.386	0.493	0.729	1.008	1.330	0.46
120	0.077	0.110	0.164	0.241	0.318	0.394	0.504	0.745	1.030	1.358	0.48
125	0.078	0.112	0.168	0.246	0.324	0.402	0.514	0.760	1.051	1.386	0.50
130	0.080	0.114	0.171	0.251	0.331	0.410	0.524	0.775	1.072	1.414	0.52
135	0.081	0.116	0.174	0.256	0.337	0.418	0.534	0.790	1.092	1.441	0.54
140	0.083	0.118	0.177	0.260	0.343	0.426	0.544	0.805	1.112	1.467	0.56
145	0.084	0.120	0.181	0.265	0.349	0.433	0.554	0.819	1.132	1.493	0.58
150	0.086	0.122	0.184	0.269	0.355	0.441	0.563	0.833	1.151	1.519	0.60
155	0.087	0.124	0.187	0.274	0.361	0.448	0.573	0.847	1.170	1.544	0.62
160	0.089	0.126	0.190	0.278	0.367	0.455	0.582	0.860	1.189	1.568	0.64
165	0.090	0.128	0.193	0.283	0.373	0.462	0.591	0.873	1.207	1.593	0.67
170	0.091	0.130	0.196	0.287	0.378	0.469	0.600	0.887	1.226	1.617	0.69
175	0.093	0.132	0.198	0.291	0.384	0.476	0.609	0.900	1.244	1.640	0.71
180	0.094	0.134	0.201	0.295	0.389	0.483	0.617	0.912	1.261	1.664	0.73
185	0.095	0.136	0.204	0.299	0.394	0.490	0.626	0.925	1.279	1.687	0.75
190	0.096	0.138	0.207	0.303	0.400	0.496	0.634	0.937	1.296	1.709	0.77
195	0.098	0.140	0.209	0.307	0.405	0.503	0.642	0.950	1.313	1.732	0.79
200	0.099	0.141	0.212	0.311	0.410	0.509	0.651	0.962	1.329	1.754	0.81
205	0.100	0.143	0.215	0.315	0.415	0.515	0.659	0.974	1.346	1.775	0.83
210	0.101	0.145	0.217	0.319	0.420	0.522	0.667	0.985	1.362	1.797	0.85
215	0.103	0.147	0.220	0.323	0.425	0.528	0.674	0.997	1.378	1.818	0.87
220	0.104	0.148	0.222	0.326	0.430	0.534	0.682	1.009	1.394	1.839	0.89
225	0.105	0.150	0.225	0.330	0.435	0.540	0.690	1.020	1.410	1.860	0.91
230	0.106	0.152	0.227	0.334	0.440	0.546	0.698	1.031	1.426	1.881	0.93
235	0.107	0.153	0.230	0.337	0.445	0.552	0.705	1.042	1.441	1.901	0.95
240	0.108	0.155	0.232	0.341	0.449	0.558	0.713	1.053	1.456	1.921	0.97
245	0.110	0.157	0.235	0.344	0.454	0.563	0.720	1.064	1.471	1.941	0.99
250	0.111	0.158	0.237	0.348	0.459	0.569	0.727	1.075	1.486	1.961	1.01

Airflow calculation example for Pressures other than listed:- $\sqrt{\frac{\text{NewPa}}{\text{OldPa}}} \times \text{Old l/s}$.

E.g. 150 mm diameter duct with PDI measuring 5 Pa, from chart = 0.034 m³/s (**34 l/s**).

New Pressure reading 35 Pa. $\sqrt{\frac{35}{5}} \times 34 = \sqrt{7} \times 34 = 2.6457513 \times 34 = \text{New Airflow } \mathbf{89 \text{ l/s}}$.

[Accurate to within 3 l/s across the range].

Reverse this procedure to determine a New Pressure from a known Airflow:- $\left[\frac{\text{New l/s}}{\text{Old l/s}}\right]^2 \times \text{Old Pa}$.

E.g. 200 diameter duct with PDI measuring 55 Pa = 215 l/s. Change to 283 l/s Airflow.

$\left[\frac{283}{215}\right]^2 \times 55 = 1.316279^2 = 1.7325904 \times 55 = \mathbf{95 \text{ Pa}}$.

PDIA Sensor Flow Rates – ACCESSORIES

k fact	0.004	0.008	0.012	0.018	0.026	0.033	0.043	0.062	0.084	0.115	
nom DIA	100	125	150	175	200	225	250	300	350	400	
exact ID	94	119	144	169	194	219	244	294	344	394	
Pa	m ³ /s	m ³ /s	m ³ /s	m ³ /s	m ³ /s	m ³ /s	m ³ /s	m ³ /s	m ³ /s	m ³ /s	inch wg
5	0.009	0.018	0.027	0.040	0.058	0.074	0.096	0.139	0.188	0.257	0.02
10	0.013	0.025	0.038	0.057	0.082	0.104	0.136	0.196	0.266	0.364	0.04
15	0.015	0.031	0.046	0.070	0.101	0.128	0.167	0.240	0.325	0.445	0.06
20	0.018	0.036	0.054	0.080	0.116	0.148	0.192	0.277	0.376	0.514	0.08
25	0.020	0.040	0.060	0.090	0.130	0.165	0.215	0.310	0.420	0.575	0.10
30	0.022	0.044	0.066	0.099	0.142	0.181	0.236	0.340	0.460	0.630	0.12
35	0.024	0.047	0.071	0.106	0.154	0.195	0.254	0.367	0.497	0.680	0.14
40	0.025	0.051	0.076	0.114	0.164	0.209	0.272	0.392	0.531	0.727	0.16
45	0.027	0.054	0.080	0.121	0.174	0.221	0.288	0.416	0.563	0.771	0.18
50	0.028	0.057	0.085	0.127	0.184	0.233	0.304	0.438	0.594	0.813	0.20
55	0.030	0.059	0.089	0.133	0.193	0.245	0.319	0.460	0.623	0.853	0.22
60	0.031	0.062	0.093	0.139	0.201	0.256	0.333	0.480	0.651	0.891	0.24
65	0.032	0.064	0.097	0.145	0.210	0.266	0.347	0.500	0.677	0.927	0.26
70	0.033	0.067	0.100	0.151	0.218	0.276	0.360	0.519	0.703	0.962	0.28
75	0.035	0.069	0.104	0.156	0.225	0.286	0.372	0.537	0.727	0.996	0.30
80	0.036	0.072	0.107	0.161	0.233	0.295	0.385	0.555	0.751	1.029	0.32
85	0.037	0.074	0.111	0.166	0.240	0.304	0.396	0.572	0.774	1.060	0.34
90	0.038	0.076	0.114	0.171	0.247	0.313	0.408	0.588	0.797	1.091	0.36
95	0.039	0.078	0.117	0.175	0.253	0.322	0.419	0.604	0.819	1.121	0.38
100	0.040	0.080	0.120	0.180	0.260	0.330	0.430	0.620	0.840	1.150	0.40
105	0.041	0.082	0.123	0.184	0.266	0.338	0.441	0.635	0.861	1.178	0.42
110	0.042	0.084	0.126	0.189	0.273	0.346	0.451	0.650	0.881	1.206	0.44
115	0.043	0.086	0.129	0.193	0.279	0.354	0.461	0.665	0.901	1.233	0.46
120	0.044	0.088	0.131	0.197	0.285	0.361	0.471	0.679	0.920	1.260	0.48
125	0.045	0.089	0.134	0.201	0.291	0.369	0.481	0.693	0.939	1.286	0.50
130	0.046	0.091	0.137	0.205	0.296	0.376	0.490	0.707	0.958	1.311	0.52
135	0.046	0.093	0.139	0.209	0.302	0.383	0.500	0.720	0.976	1.336	0.54
140	0.047	0.095	0.142	0.213	0.308	0.390	0.509	0.734	0.994	1.361	0.56
145	0.048	0.096	0.144	0.217	0.313	0.397	0.518	0.747	1.011	1.385	0.58
150	0.049	0.098	0.147	0.220	0.318	0.404	0.527	0.759	1.029	1.408	0.60
155	0.050	0.100	0.149	0.224	0.324	0.411	0.535	0.772	1.046	1.432	0.62
160	0.051	0.101	0.152	0.228	0.329	0.417	0.544	0.784	1.063	1.455	0.64
165	0.051	0.103	0.154	0.231	0.334	0.424	0.552	0.796	1.079	1.477	0.67
170	0.052	0.104	0.156	0.235	0.339	0.430	0.561	0.808	1.095	1.499	0.69
175	0.053	0.106	0.159	0.238	0.344	0.437	0.569	0.820	1.111	1.521	0.71
180	0.054	0.107	0.161	0.241	0.349	0.443	0.577	0.832	1.127	1.543	0.73
185	0.054	0.109	0.163	0.245	0.354	0.449	0.585	0.843	1.143	1.564	0.75
190	0.055	0.110	0.165	0.248	0.358	0.455	0.593	0.855	1.158	1.585	0.77
195	0.056	0.112	0.168	0.251	0.363	0.461	0.600	0.866	1.173	1.606	0.79
200	0.057	0.113	0.170	0.255	0.368	0.467	0.608	0.877	1.188	1.626	0.81
205	0.057	0.115	0.172	0.258	0.372	0.472	0.616	0.888	1.203	1.647	0.83
210	0.058	0.116	0.174	0.261	0.377	0.478	0.623	0.898	1.217	1.667	0.85
215	0.059	0.117	0.176	0.264	0.381	0.484	0.631	0.909	1.232	1.686	0.87
220	0.059	0.119	0.178	0.267	0.386	0.489	0.638	0.920	1.246	1.706	0.89
225	0.060	0.120	0.180	0.270	0.390	0.495	0.645	0.930	1.260	1.725	0.91
230	0.061	0.121	0.182	0.273	0.394	0.500	0.652	0.940	1.274	1.744	0.93
235	0.061	0.123	0.184	0.276	0.399	0.506	0.659	0.950	1.288	1.763	0.95
240	0.062	0.124	0.186	0.279	0.403	0.511	0.666	0.960	1.301	1.782	0.97
245	0.063	0.125	0.188	0.282	0.407	0.517	0.673	0.970	1.315	1.800	0.99
250	0.063	0.126	0.190	0.285	0.411	0.522	0.680	0.980	1.328	1.818	1.01

Airflow calculation example for Pressures other than listed:- $\sqrt{\frac{\text{NewPa}}{\text{OldPa}}} \times \text{Old I/s}$.

E.g. 150 mm diameter duct with PDIA measuring 5 Pa, from chart = 0.027 m³/s [27 I/s].

New Pressure reading 10 Pa. $\sqrt{\frac{10}{5}} \times 27 = \sqrt{2} \times 27 = 1.4142135 \times 27 = \text{New Airflow } \underline{38 \text{ I/s}}$.

(Accurate to within 1 I/s across the range)

Reverse this procedure to determine a New Pressure from a known Airflow:- $\left[\frac{\text{NewI/s}}{\text{OldI/s}}\right]^2 \times \text{Old Pa}$.

E.g. 200 diameter duct with PDIA measuring 55 Pa = 193 I/s. Change to 279 I/s Airflow.

$\left[\frac{279}{193}\right]^2 \times 55 = 1.4455958^2 \times 55 = 2.0897472 \times 55 = \underline{115 \text{ Pa}}$.

ACCESSORIES – Turning Vane/Flow Measuring & Balancing

Models: **TVMA-90, TVMAI-90 (Insulated),
TVA-90, TVAI-90 (Insulated).**

Model TVA-90 is an inlet adaptor primarily intended for use with series CMP square diffusers. It has been developed in recognition of the fallacy of so-called “cushion head boxes” which provide no better discharge pattern than a hard 90° bend. The turning vanes, set at 75 mm spacing, minimise asymmetry of discharge air.

Model TVMA-90 is similar, but with a PDIA averaging flow measuring probe, which provides an amplified pressure differential to be read by Magnahelic, or micromanometer. This pressure differential, when used with the formula provided gives fast, reliable and accurate air flow data without the distortion created by a collector funnel and with no significant friction loss.

For both measuring and non measuring units, listed sizes are standard for CMP type diffusers. Other square or rectangular sizes can be furnished to special order. Both are available either plain, or internally lined with 14 mm insulation.

Turning Vane Arrangement

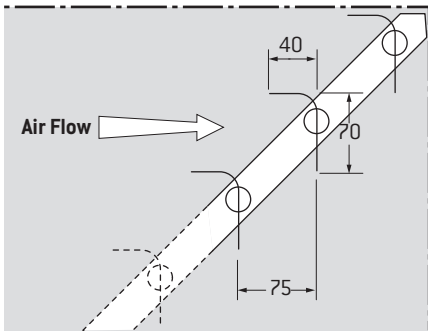

Note: For weight details contact your local Holyoake branch.

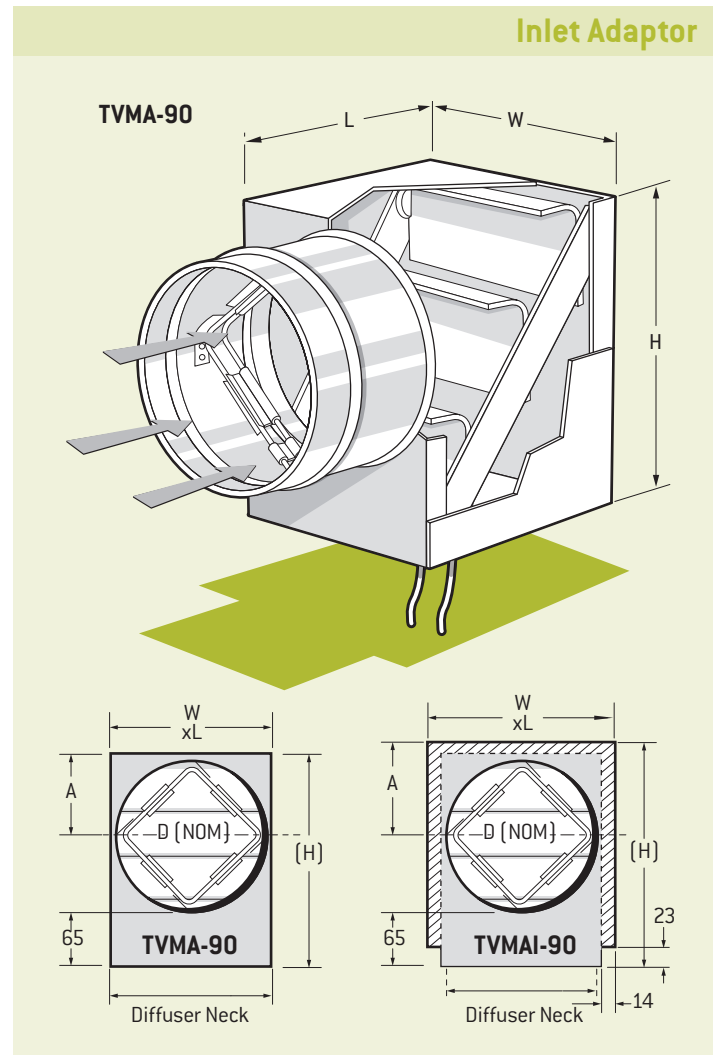

SIZE (Diffuser Neck)	No. of VANES	UNINSULATED				INSULATED 14 mm		
		D Max	W & L	H	A	W & L	H	A
150 x 150	2	150	155	215	75	180	229	89
225 x 225	3	225	230	290	113	255	304	127
300 x 300	4	300	305	365	150	330	379	164
375 x 375	5	375	380	440	188	405	454	202
450 x 450	6	450	455	515	225	480	529	239

Models: **PDI-BS, PDIA-BS.**

Flow Balancing Stations.

Models PDI-BS and PDIA-BS are balance stations consisting of a flow sensor mounted with a lever arm controlled disc damper, in a short section of round duct. They provide an excellent inexpensive method of balancing branch ducts using a pressure differential measuring instrument, as described for flow sensors on page 379K. Use PDIA-BS where duct velocities are between 2.5 m/s and 10 m/s and PDI-BS between 5 m/s and 14 m/s.

Flow Balancing Station – Sizes Available								
100	125	150	175	200	225	250	300	400

Note: For weight details contact your local Holyoake branch.

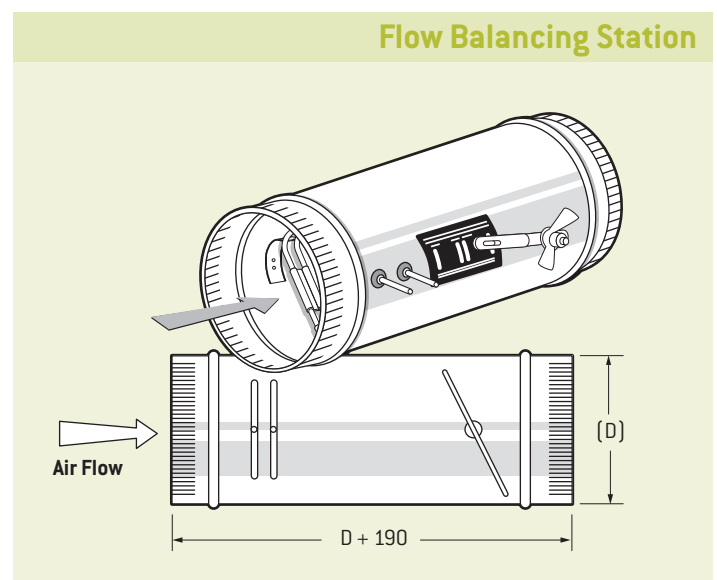

Access Doors/Duct Flange – ACCESSORIES

Models: ADC-2, ADH-2 – Access Door.

Galvanised steel frame and double skin panel, insulation filled and fitted with cam-locks both sides (ADC-2), or with hinge pin on one side and cam-locks on the other (ADH-2).

Frame is dove-tailed to provide easy folding tabs, which lock it in to a prepared hole in the duct, or panel.

Models ADC-2 and ADH-2 Standard Sizes			
200 x 200	250 x 250	300 x 300	400 x 400
450 x 450	500 x 500	600 x 600	

Other sizes are available to special order.

Guide Product Weights	
Size	Approximate Weight in Kg.
	ADC-2
250 x 150	1.05
300 x 300	1.48
400 x 400	2.63

Minimum Side: 150 mm

Maximum Side: 600 mm

Cam-locks: Up to 300 mm Side, 1 Cam-Lock.
Above 300 mm Side, 2 Cam-Locks.

Material: 0.55 galvanised steel and polyester based insulation.

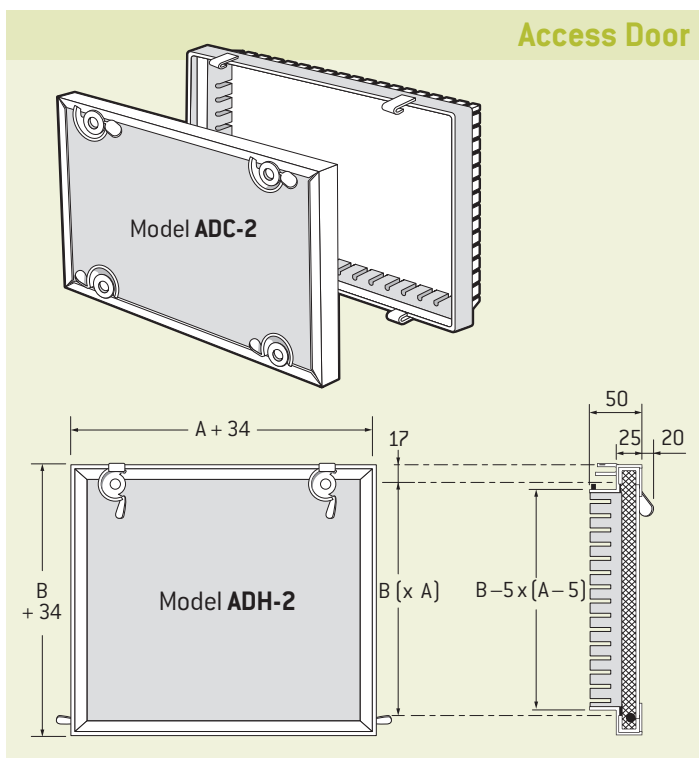

Model: Duct Flange – Flanging System

The Duct Flange Flanging System provides a secure airtight joint for connecting individual duct sections, dampers and other accessories together.

Constructed from roll-formed galvanized steel, in either 25 mm, or 35 mm high by 5.8 m lengths, which can be cut to size on site, by others. All Duct Flange angle incorporates an integral sealant. Matching pressed steel zinc plated corners slide into the roll-formed section to make a rigid, four sided frame. Clips are furnished with these corners to make a simple and secure fixing. (Bolt holes are provided, which can be used for aligning the corners, or for a more secure fixing. Nuts and bolts by others). Do **not** use bolts for Fire Damper Breakaway Joints.

The raw edge of the duct end slides fully into the open roll-formed section of the flange and its mastic sealant. It should then be held in place by either spot welds, or self drilling Tek screws. Duct Flange DM Seal Gasket Tape should be applied to the face of the flange and the corners of the mating flange.

Simple 'J' Cleats should be installed, which snap over the frame to secure and seal two pieces of Duct Flange together.

The recommended minimum spacing of snap on 'J' Cleats is shown in the following table:

Description	Part No.	0.5 kPa	1.0 kPa	1.5 kPa
Duct Flange 25mm	DF 25	450 mm	300 mm	150 mm
Duct Flange 35mm	DF 35	600 mm	450 mm	300 mm

The following figures use SMACNA Duct Construction Standards recommendations. They provide a guide to flanged joint limitations using 0.8 mm flange wall thickness, without intermediate reinforcement, or internal bracing.

The Maximum Duct Size can be increased by altering these parameters. Refer to SMACNA.

Description	Part No.	Maximum Duct Size (W x H mm)			Gasket Size mm
		Maximum Spacing of Flanges			
		0.5 kPa	1.0 kPa	1.5 kPa	
Duct Flange 25 mm	DF 25	1200 x 1200	900 x 1200	900 x 1200	18 x 6
Duct Flange 35 mm	DF 35	1500 x 1500	1200 x 1200	1200 x 1200	18 x 6

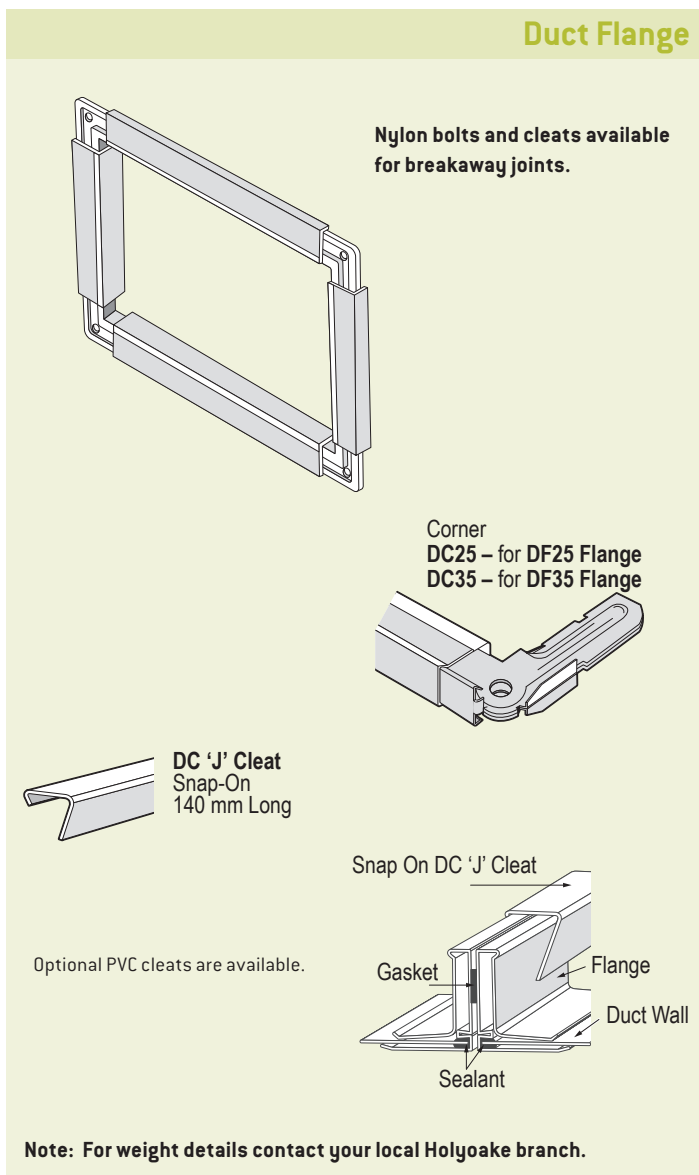

ACCESSORIES – Grille & Diffuser Fixing Systems

Chain Fixing System

Designed for easy, positive fixing of a large range of grilles and linear (LD) diffusers. The system consists of a spring (hooked, or riveted to the duct wall on each side), fixed to the end of a chain.

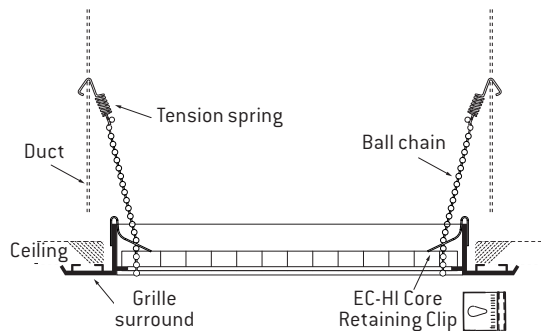

When the chain is pulled through a unique ratchet clip, which is attached to the rear of the grille, or diffuser, a tight, positive installation is made.

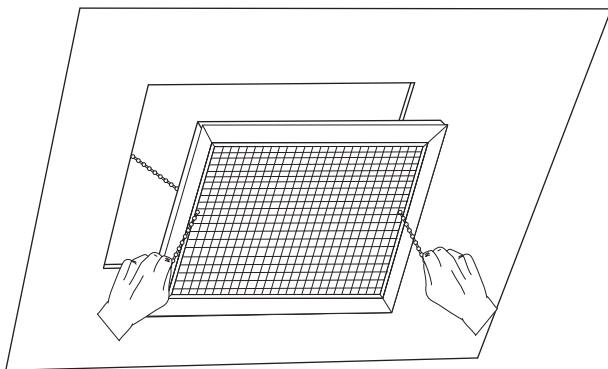

This system is particularly useful for a fast and easy, concealed, mechanical fixing; which in many installations would otherwise be time consuming and expensive.

Each fixing set includes:

- 2 Ball Chains.
- 2 Springs.
- 2 Ratchet Clips.

Concealed Fixing System

Designed to fix and install light weight grilles, to show no fixing from grille face, for ease of access, for cleaning, etc. This system consists of a Spring Clip, pop riveted to both sides of the grille, as shown.

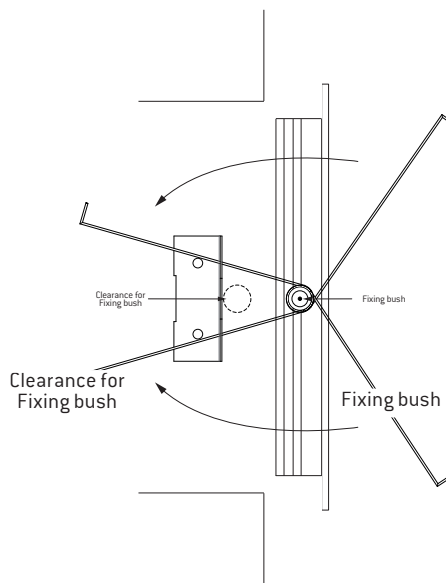

The ends of the spring clip are inserted into a retaining bracket, which has been fixed to the inside of the duct on both sides. The spring ends are folded at 90 degrees to ensure that when the grille is lifted for maintenance, the retaining brackets allow the grille to be partially removed, without completely separating the two.

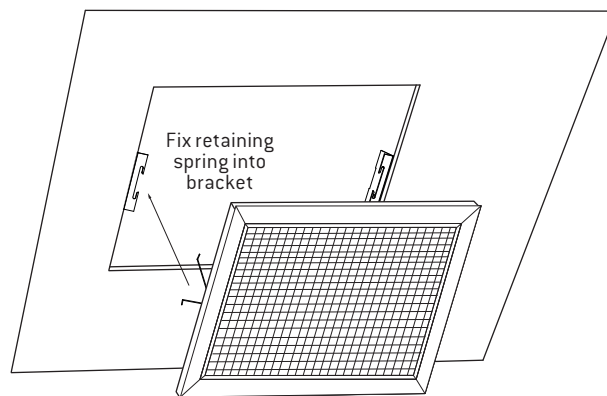

This system is particularly good for regular removal for access, cleaning, etc.

Each fixing set includes:

- 2 Ferrules.
- 2 Springs.
- 2 Retaining Brackets.
- 2 Pop Rivets.

Note: Weights of Fixing Systems, subject to style and quantity required, contact your local Holyoake branch.

Refer also to Removable Core Frame Options on page 228E.

Access Panels/HVAC Tools – ACCESSORIES

Model: **APP**

Model APP is a pressed steel access panel which is available in three sizes, small (250 x 150), medium (300 x 200) and large (450 x 350). The APP is installed by simply cutting a hole in the duct as per the template provided and then inserting the access panel. No fastenings are required.

Overall Panel Size (mm)	Hole Cut Size (mm)	Guide Product Weights
		Approximate Weight in Kg.
280 x 180	250 x 150	APP 1.03
330 x 230	300 x 200	1.56
480 x 380	450 x 350	3.58

Note: The hole in the duct should be cut using the supplied template.

Access Pressed Panel

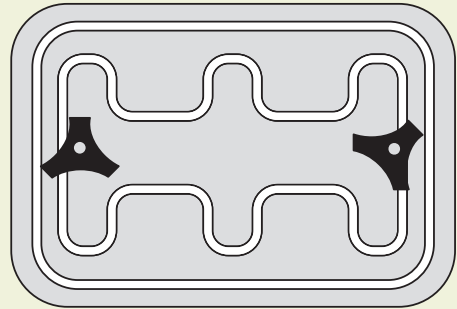

ACCESSORIES – Premi-Aire™ Cushion Head

Model: **Series Premi-Aire™**

Pre-Insulated Cushion Head, Plenum & Adaptor Boxes.

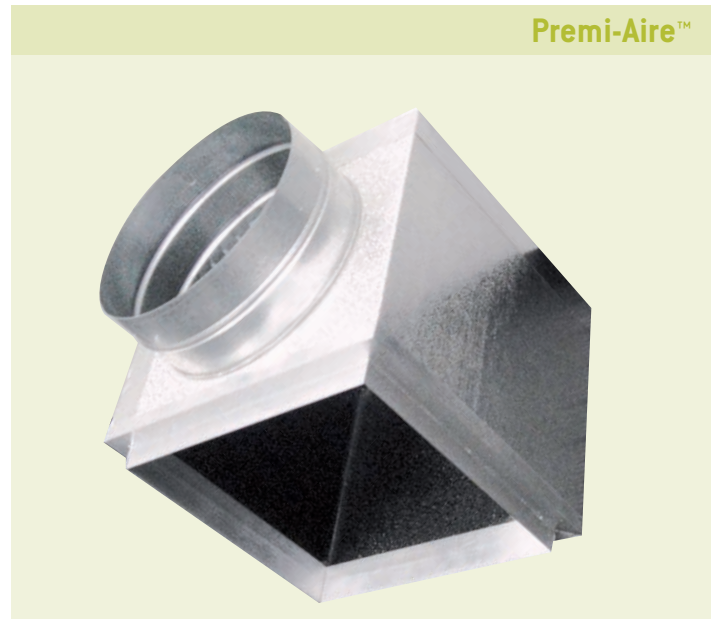
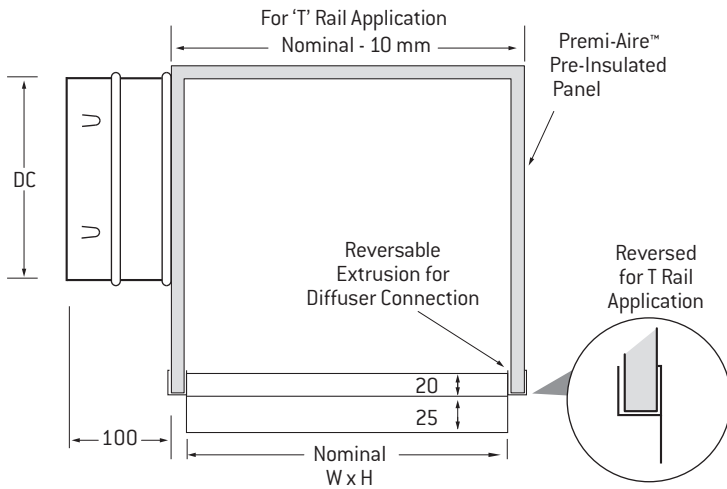

The Premi-Aire™ range adapts ceiling swirl, multi pattern, square neck diffusers, return grilles, linear diffusers and other applications to a side or top entry, round, oval or square/ rectangular spigot connection/or proprietary Duct Flange connecting arrangement.

Options

Applications for the Holyoake Premi-Aire™ include Cushion Head, plenum, and adaptor boxes.

Product Range

Square neck, adaptor boxes, supply and return plenums and other special arrangements are available. Please contact your local Holyoake branch for details.

Holyoake's Premi-Aire™ pre-insulated box system offers installers and specifiers many benefits:-

Features

- Ultra light weight, robust, and strong design.
- Easy to install.
- High thermal resistance and lower pressure drop.
- Certified to AS/NZS 1530.3 (0, 0, 0, 0-1).
- Range of spigot and duct flange options.
- Aesthetically pleasing black internal foil face.

Material

Manufactured in a sandwich panel construction, a layer of fire proof rigid closed cell foam, is laminated both sides with aluminium foil, silver external and black internal.

Ordering Code Examples and Suggested Specification

PREMI -CH	–	CRS CSS CFP CFPP	–	DC	–	W x H
Premi-Aire™ Cushion Head.		Product Type.		Duct Connection, (Dia/Oval/Square Rect/Duct Flange).		Nominal Diffuser, (or Grille Neck Size).

Specification

The Premi-Aire™ Cushion Head boxes shall be constructed from aluminium foil laminated silicate modified fire proof rigid Polyurethane and be complete with galvanised steel connection spigots and accessories, as appropriate.

All as manufactured by Holyoake.

Please refer to page 388K for product weights.

Pre-Insulated Duct System – PREMI-AIRE™

Holyoake's **Premi-Aire™** pre-insulated duct system is revolutionising the design, fabrication and installation of HVAC systems.

Applications for Holyoake **Premi-Aire™** pre-insulated duct system are virtually limitless and include Cushion Heads, plenums and linear adaptors, as well as complete duct systems for HVAC applications.

Improved System Efficiency

Premi-Aire™ pre-insulated duct system has a high thermal resistance, which reduces heat losses through the wall of the panel. The unique assembly system reduces air leakage, by improving joint sealing and reducing the number of joints. The black aluminium foil lining reduces system resistance and also creates a smooth, cleanable surface, that assists with future maintenance schedules.

Enhanced building design

Designed to reduce the impact of the HVAC system on building design, **Premi-Aire™** pre-insulated duct system is up to 90% lighter than traditional sheet metal duct systems, potentially reducing the structural design requirements in a building. As a pre-insulated panel, there is no need to make allowances for access for external insulation installed on site, reducing the required ceiling space. Holyoake's **Premi-Aire™** pre-insulated duct system is manufactured without CFC's, ensuring the completed system has minimal impact on the environment.

Compliant with BCA & NZBC

Holyoake's **Premi-Aire™** pre-insulated duct system has been tested at the NATA certified, CSIRO laboratory in Australia and conforms to the requirements of the Building Code of Australia, AS 1530.3 and AS 4254. **Premi-Aire™** pre-insulated duct panel is built to exacting international quality standards with ISO 9001: 2008 Certification.

New Zealand supplied **Premi-Aire™** also complies with ISO9705 in accordance with NZBC C/VM2 Appendix A and has a group classification number 1-S (highest available).

Ease of installation and construction

Premi-Aire™ pre-insulated duct system caters for the needs of designers, fabricators and installers to reduce construction and on-site time when compared to traditional methods. Holyoake can provide the complete tooling and training needs for workshop and on-site staff, as well as project costing software for the estimator.

Applications

- Grille / Diffuser Cushion Head boxes.
- Linear adaptor boxes.
- Low to medium pressure applications for plenums and ducting, however final selection is dependant on all application data, therefore, **please refer to your local Holyoake Branch for specific applications.**

Design And Manufacture

- CAD / CAM facilities for automated CNC machining, are available.
- Certified to ISO 9001:2008.
- Various connection methods available including standard "h" section and 35mm Proprietary Duct Flange Systems.

Advantages

- Standard range of products available.
- Specials can be manufactured to meet specific requirements.
- Ultra lightweight (enhancing health & safety), robust and strong design.
- Reducing structural design requirements with regards to seismic bracing, especially with the new slim line ceiling grids.
- Easier to install and position in both solid and grid ceilings.
- High thermal resistance.
- Round/Oval/Square/Rectangular spigots (can be supplied loose).
- Duct flange options also available.
- Minimal impact on the environment being CFC free.

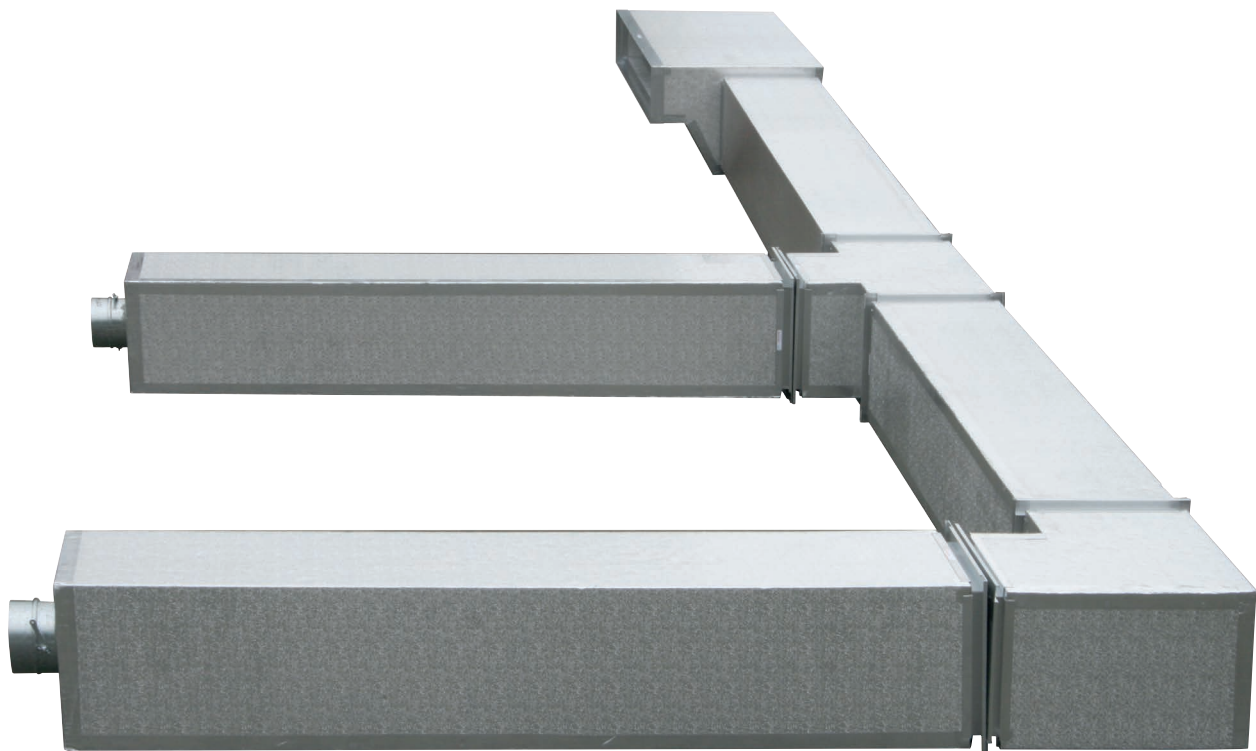

PREMI-AIRE™ – Applications

Supply Plenum

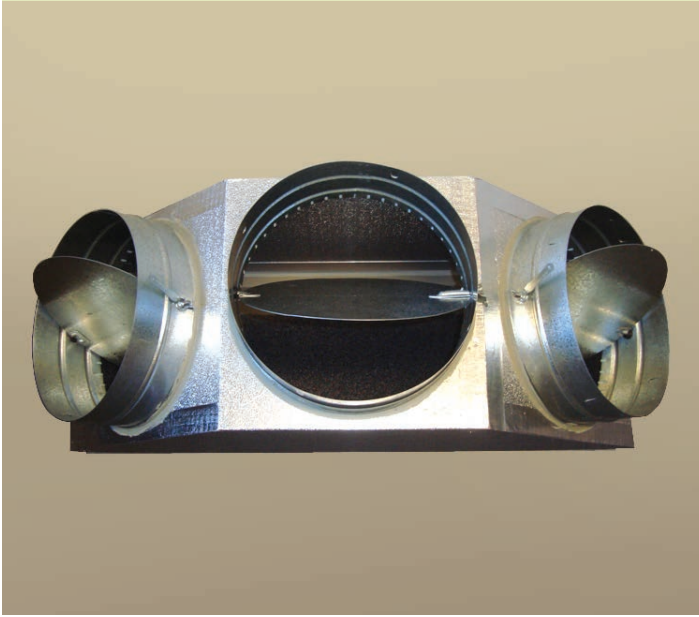

Cushion Head Adaptor with Circular Spigots

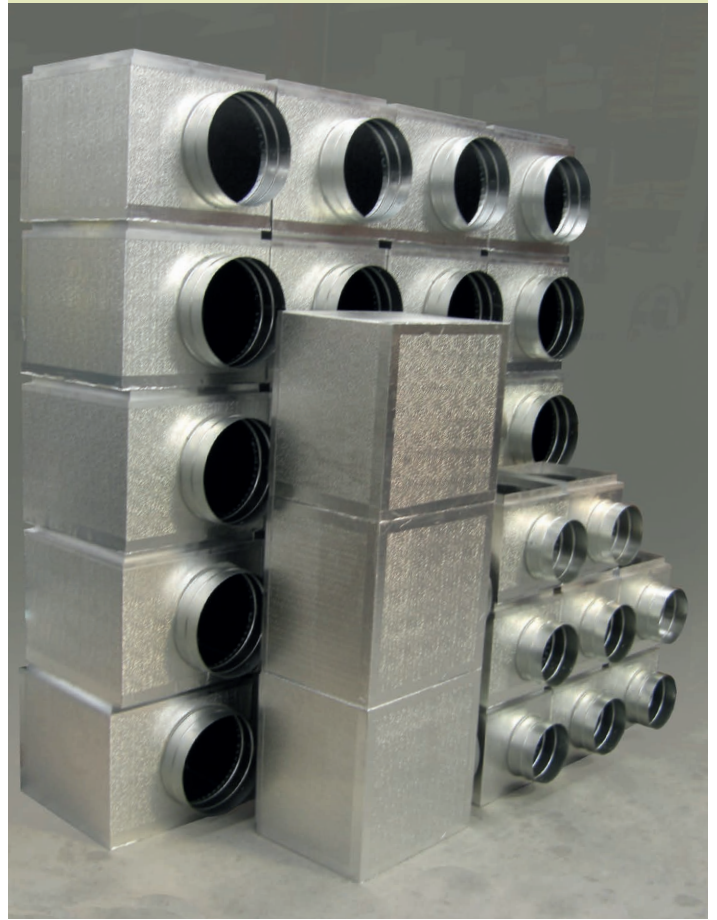

CNC Machine

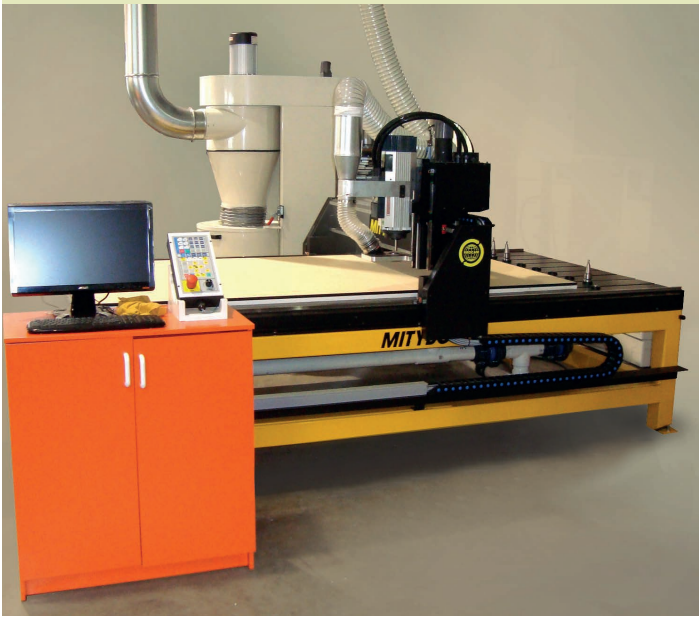

Cushion Head Adaptor with Oval Spigots



Guide Product Weights

Approximate Weight in Kg

Size	Premi-Aire Cush Head	Size	Premi-Aire Cush Head
CRS 300	1.50	225 SQ CH	1.10
CRS 450	2.50	300 SQ CH	1.20
CSS 450	2.10	375 SQ CH	2.00
CSS 600	2.70	450 SQ CH	2.50
595 SQ T Rail	2.60	595 SQ CH	2.60

Product Ordering Key and Suggested Specifications

Product Reference	Quantity +	Description	Listed Size, W x H or Diameter +	Specification
ADC-2	1	Access Door Tab Type with Cam Locks.	450 x 450	ADC-2 and ADH-2 - Access Doors shall be constructed from double skin galvanized mild steel and are complete with cam locks and hinges, as appropriate. Dove tailed frame tabs are supplied for ease of installation. All shall be as manufactured by Holyoake.
ADH-2	5	Access Door Tab Type Hinged with Cam Locks.	200 x 200	
APP	4	Access Pressed Panel.	APP-SML (250 x 150) APP-MED (300 x 200) APP-LGE (450 x 350)	APP - Access Pressed Panels shall be constructed from galvanized mild steel and are complete with locking knobs. All shall be as manufactured by Holyoake.
AS25L	3	Air Scoop, Blades Parallel to Long Dimension.	900 x 300	AS25/AS50 Air Scoops - shall be constructed from a zinc coated steel casing with gang operated parallel blades (at 25, or 50 mm Pitch) and a hinged pre-punched strip, for setting. All shall be as manufactured by Holyoake.
AS25S	1	Air Scoop, Blades Parallel to Short Dimension.	300 x 900	
AS50L	5	Air Scoop, Blades Parallel to Long Dimension.	900 x 300	
AS50S	7	Air Scoop, Blades Parallel to Short Dimension.	300 x 900	
CH		Cushion Head - Ordering Codes & Specifications are shown on Page 376K & 386K		
DA25	4*	25 mm Duct Flange 5.8 m length.		DUCT FLANGE Duct Flanging System - For secure airtight joints for ductwork, dampers, and accessories. All shall be as supplied by Holyoake.
DA35	4*	35 mm Duct Flange 5.8 m length.		
DA25	16*	25 mm Corner (with clips) for use with DA25 Flange.		
DC35L	16*	35 mm Corner (with clips) for use with DA35 Flange.		
DCJ	256*	140 mm long snap on 'J' Cleats.		
DM SEAL	3*	15 m roll of Duct Flange Gasket Tape.		
* Guide to form 8 o° 12 00 x 1200 Flange Assemblies.				
DUCT TAPE	5	Each.	Silver Duct Tape 48 mm x 55 mm.	Duct Tape - A premium grade polyethylene coated cloth duct tape. All shall be as supplied by Holyoake.
	1	Carton of 24.		
EGS	5	Equalising Grid, Square, or Short Blades (600 x 600 Maximum).	Grille/Diffuser Neck Size, or Nominal Neck Size	EGS / EGL - Equalising Grids shall be constructed from extruded aluminium blades and Casing, stainless steel friction wire interlaced with blade axles, hold the required setting. Bright zinc plated clips fix the grids to the neck of the diffusers, or grille. All shall be as manufactured by Holyoake.
EGL	4	Equalising Grid, Long Blades (600 x 600 Maximum).	Grille/Diffuser Neck Size, or Nominal Neck Size	
OBD-1	5	Extruded Black Anodised Aluminium - OBD.	200 x 200	OBD - Opposed Blade Dampers shall be constructed from extruded black anodised aluminium. All shall be as manufactured by Holyoake.
OBD-2	7	Extruded Black Anodised Aluminium - OBD.	300 x 300	
OBD-3	2	Extruded Black Anodised Aluminium - OBD.	500 x 200	

+ Example

ACCESSORIES

Product Ordering Key and Suggested Specifications

Product Reference	Quantity +	Description	Listed Size, W x H, or Diameter +	Specification
PDI	3	Pressure Differential Indicator Sensor.	100 DIA	PDI/PDIA/FM-PDI/FM-PDIA/DM-PDIA/PDI-BS/PDIA-BS- Pressure Differential Indicator sensors and Flow Measuring and Flow Balancing stations shall be constructed from small diameter tubing with Galvanised steel sleeves and disc dampers where appropriate. All shall be as manufactured by Holyoake.
PDIA	7	Pressure Differential Indicator Sensor - Amplified.	150 DIA	
FM-PDI	2	PDI Flow Measuring Station.	300 DIA	
FM-PDIA	3	PDI Flow Measuring Station - Amplified.	400 DIA	
DM-PDIA	6	Flange Mounted PDIA for Rectangular Ducts.	Size 150	
PDI-BS	3	Flow Balancing Station.	100 DIA	
PDIA-BS	3	Flow Balancing Station - Amplified.	175 DIA	
PREMI-CH		PREMI-AIRE™ Cushion Head - Ordering Codes and Specification are shown on Page 386K.		
PREMI-AIRE™		PREMI-AIRE™ Pre-Insulated Duct System. See Page 387K.		
RD	20	Radial Balancing Damper.	RD 150	RD - Radial Balancing dampers shall be constructed from Galvanised Mild steel with UV Stabilized Fire Rated Polymer Drive Pinions. All shall be as manufactured by Holyoake.
SAB	10	Self Aligning Bend.	SAB 100	SAB - Self Aligning Bends shall be manufactured in four segments from Galvanized steel, to allow 90° to 180° bends. They shall be crimped both ends to insert into Spiroloc ducting. All shall be as manufactured by Holyoake.
SB (For use with CRA, CRP, CSRL, CSRLA, CSRV and CMP).	4	Sectorising Baffles.	Inlet DIA Neck Connection 300 DIA.	SB - Sectorising Baffles are satin etched black on steel and shall be manufactured in 45° sections, except CMP. All shall be as manufactured by Holyoake.
SPIN CON	10	Spin Connector (Suitable for Rigid, Semi Rigid and Flexible Ducting).	Nominal Duct DIA 300 DIA.	Spin Connectors/Spin Collars – shall be constructed from Galvanized Steel of 0.45 mm for sizes 100 - 250 mm and 0.55 mm for sizes 251 - 400 mm. For connection of Duct to Duct (Spin Con), or to provide a circular duct connection (Spin Collar), to a square, or rectangular plenum. All shall be as manufactured by Holyoake.
SPIN COL	5	Spin Collar (Suitable for Flexible Ducting).	Nominal Duct DIA 200 DIA.	
SSD	2	Stream Splitter Damper.	Neck Size 900 mm x 300 mm.	SSD - Stream Splitter Dampers shall be constructed from zinc coated steel finished in matt black and shall be designed to control volume and direction from a main to a branch duct. All shall be as manufactured by Holyoake.
SRA **	7	Square to Round Adaptor.	Nom W x H x DIA.	SRA/RRA/SSA – Square to Round, Rectangular to Round and Square to Square Adaptors shall be constructed from 0.55mm Galvanized Steel and shall be complete with a circular spin collar to suit circular duct, or a square duct connection. All shall be as manufactured by Holyoake.
RRA **	6	Rectangular to Round Adaptor.	Nom W x H x DIA.	
SSA **	7	Square to Square Adaptor.	Nom (W x H) x Nom (W x H).	
** (For use with HI35, EC125, OBD-1, 2, 3, RD, BD 85 and other options).				
TRV	5	Throwing Reduction Vanes.	300 mm x 300 mm 5 Vanes.	TRV - Throw Reducing Vanes shall be manufactured from sheet Aluminium and shall be affixed to the rear of a CMP Diffuser. All shall be as manufactured by Holyoake.
TVS	2	Turning Vane, Short Blades.	150 mm x 300 mm.	TVS/TVL – Turning Vanes have curved blades and shall be constructed from extruded aluminium. They shall be hinged and complete with a pre-punched strip for fixing.
TVL	2	Turning Vane, Long Blades.	300 mm x 150 mm.	
TVA-90	3	Turning Vane Arrangement, Inlet Adaptor.	Diffuser Neck 150 mm x 150 mm.	All shall be as manufactured by Holyoake.
TVMA-90	1	Turning Vane Arrangement with PDIA, Inlet Adaptor.	300 mm x 150 mm.	TVA-90/TVMAI-90/TVAI-90 and TVMA-90 - Turning Vane arrangements shall be constructed from zinc coated steel and finished in matt black and shall be designed to provide a better discharge pattern and accurate flow data, as appropriate. All shall be as manufactured by Holyoake.
TVAI-90	5	Turning Vane Arrangement, Inlet Adaptor (Insulated).	375 mm x 375 mm.	
TVMAI-90	2	Turning Vane Arrangement with PDIA, Inlet Adaptor (Insulated).	300 mm x 300 mm.	

+ Example