

LR

FIRE / FIRE AND SMOKE / SMOKE  
AND BALANCING DAMPER

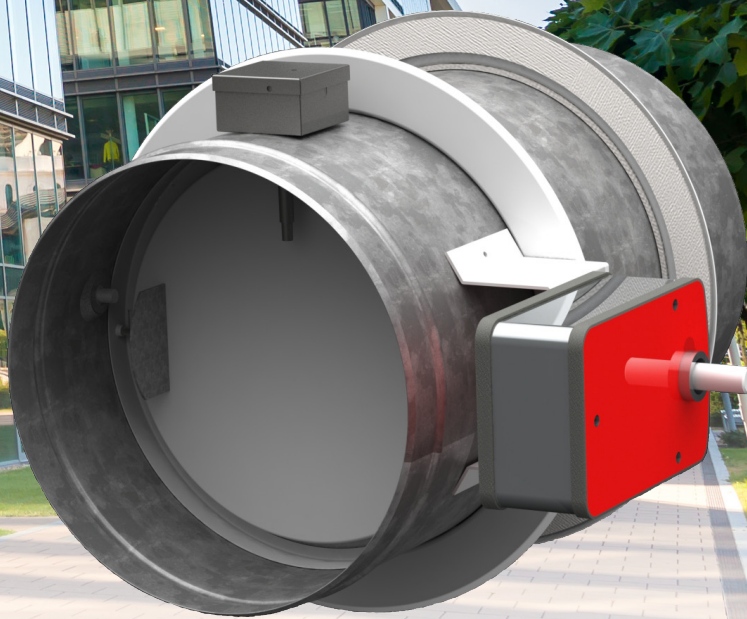

**HOLYOAKE**  
AIR MANAGEMENT SOLUTIONS | by price



# MODEL: LR

## FIRE / FIRE AND SMOKE / SMOKE (EXHAUST) AND BALANCING DAMPER

The Holyoake Series LR fire / combination fire and smoke dampers are designed to impede the spread of fire and smoke between building compartments, whilst maintaining the barriers integrity. The low leakage damper blade assembly, with blade tip sealing ring, forms a solid barrier against flame, smoke, and hot gases. This leakage performance is guaranteed by our quality control process that we conduct on each damper.

### LR 100 - LR 250 FIRE / SMOKE RATING:

Tested in accordance with AS 1530.4 - 2014 and AS 1530.7 - 2007, integrity was maintained for in excess of four hours and smoke leakage below 50l/s.

For the purposes of the Australian National Construction Code and New Zealand Building Code, the damper has a F.R.L./F.R.R. of -/240/- in a masonry wall / floor and -/120/- in a plasterboard wall, timber framed floor, and Hebel system.

### LR 300 AND LR 350 FIRE / SMOKE RATING:

Tested in accordance with AS 1530.4 - 2014 and AS 1530.7 - 2007, integrity was maintained for in excess of 90 minutes and smoke leakage below 50l/s.

For the purposes of the Australian National Construction Code and New Zealand Building Code, the damper has a F.R.L./F.R.R. of -/90/- in a masonry wall / floor, plasterboard wall, timber framed floor, and Hebel system.

## FEATURES

- Simple installation with flat head screwdriver utilising patented clamping system:
  - No sealant.
  - No fixings required.
- Minimal onsite labour.
- Smoke leakage rated to AS 1530.7 - 2007.
- Optional actuator and attachment (by others) required for smoke damper functionality.
- Available in seven diameters: 100, 125, 150, 200, 250, 300, and 350mm.
- Easy test and reset fusible link.
- Adjustable blade for airflow balancing.

**NOTE:** LR 100 utilises the LR 125 damper with 100-125 adaptor collars.

## CONFIGURATIONS

- LR fire damper with brass fusible link.
- LR combination fire and smoke damper with spring return actuator and electro-thermal link.
- LR smoke (exhaust) damper with spring return actuator.
- LR balancing damper with either brass fusible link or actuator; applicable in combination with the other damper configurations.

## CERTIFICATION

### CSIRO

**Fire Test Certificate No. COA 3316 in accordance with AS 1530.4 - 2014 : Section 11 (Ducted Damper Installations).**

(LR 100 - LR 250 certified for 240 minute fire rating).

(LR 300 and LR 350 certified for 90 minute fire rating).

### WARRINGTONFIRE

**Smoke Leakage Test Certificate No. SFC 53556800.2 and SFC 2100015.1 in accordance with AS 1530.7 - 2007.**

**Leakage below 50l/s @ 200°C in accordance with AS 1682.1-2015.**

The LR damper can be supplied as either a fire, smoke (exhaust), or fire and smoke damper with the ability to be set to balance the airflow. It is quick and easy to install, maintain, and test. The unit comes complete with mounting flanges, jubilee clip, and the patented heat shield is supplied for plasterboard applications.

Fire protection is provided by a fusible link (manual or electro-thermal) and damper blade that seals the duct shut in the event of a fire to maintain minimum leakage as required by the test standard.

## KEY INSTALLATION DETAILS

- No internal linings are required for the majority of plasterboard penetrations.
- Standard sleeve configuration suits barriers up to 190mm.
- Extended sleeve configuration suits barriers up to 295mm.
- Assessed to be installed 35mm from the damper to the adjacent element and 70mm between two LR dampers.
- Actuators available as either 24V or 240V.
- Penetration sizing (cut-out template on packaging):

Damper Size (Ø)	Penetration (mm)
LR100/125	130 - 138
LR 150	155 - 163
LR 200	205 - 213
LR 250	255 - 263
LR 300	305 - 313
LR 350	355 - 363

**NOTE:** See pages four - seven for detailed installation guides, including specific instructions for all plasterboard installations.

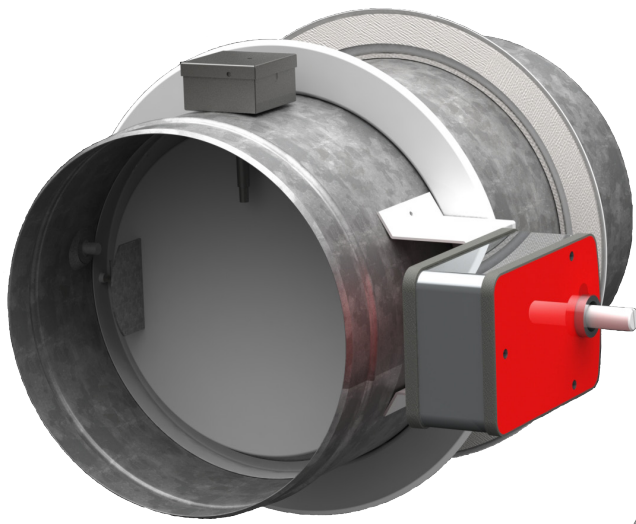

LR Fire and Smoke Damper

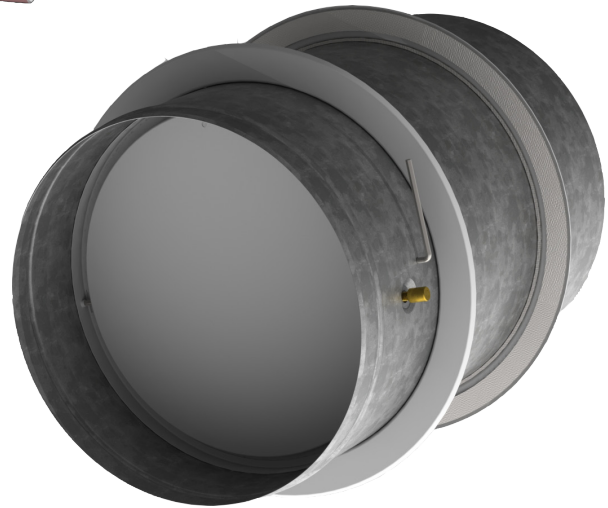

LR Fire Damper

**DIMENSIONS:**

Standard Configuration (suits fire barriers up to 190mm)

Extended Sleeve Configuration (suits fire barriers up to 295mm)

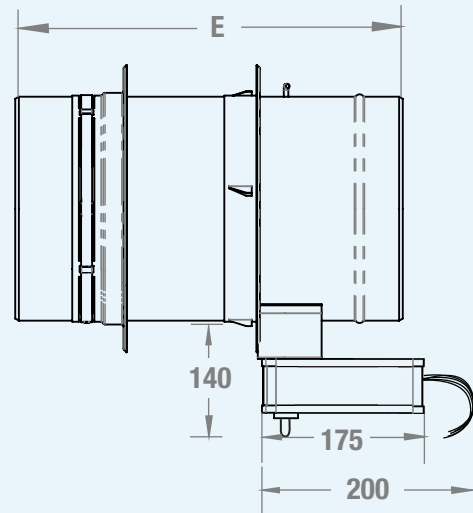
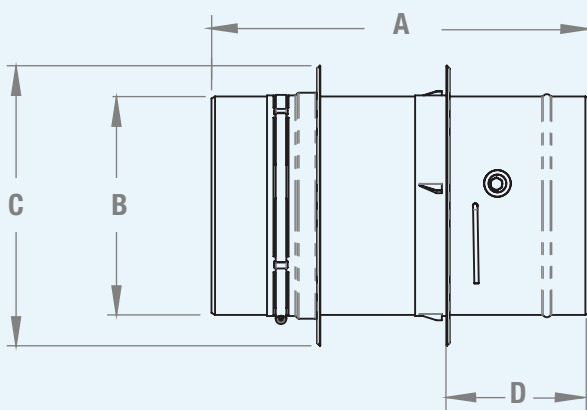

	LR 100 / LR 125	LR 150	LR 200	LR 250	LR 300	LR 350
A	425	425	425	425	-	-
B	96 / 121	146	196	246	296	346
C	190	215	265	315	365	415
D	150	150	150	150	150	150
E	530	530	530	530	530	530

NOTE: All dimensions are in mm

## MASONRY, DRYWALL, AND TIMBER FRAMED FLOOR INSTALLATIONS

### INSTALLATION INSTRUCTIONS

1. Cut penetrations as per table below. For a masonry and drywall installation use the left column and for a timber framed floor refer to special instructions below.
2. Insert Holyoake flexible heat shield into penetration (plasterboard applications only).
3. Remove loose flange from damper.
4. Insert damper through penetration until fixed flange is firmly seated on the fire barrier.
5. Slide loose flange (with seal side facing wall) onto damper and tighten jubilee clip with screwdriver.
6. Using damper handle and fusible link, test damper operation and then set blade to required position.

Damper Size (Ø)	Standard Penetration (mm)	Timber Flooring Penetration* (mm)
LR100/125	130 - 138	160 - 180
LR 150	155 - 163	185 - 205
LR 200	205 - 213	235 - 255
LR 250	255 - 263	285 - 305
LR 300	305 - 313	335 - 355
LR 350	355 - 363	385 - 405

\*Penetration size for timber framed floors 17mm min. flooring

### SPECIAL PENETRATION SIZING FOR TIMBER FRAMED FLOOR INSTALLATION

The penetration through a timber framed floor requires two uniquely sized holes. These dimensions can be found in the table above and are explained below:

1. The plasterboard underside is to be cut as per the dimensions in the left column (Standard Penetration) of the table.
2. The flooring on the top side of the penetration, is to be cut to the larger diameter sizing in the right column (Timber Flooring Penetration) of the table. This is to incorporate the flexible heat shield.
3. The inner diameter of the separator is to be sized as per the plasterboard underside (left column - Standard Penetration - of table) and must have at least 10mm of coverage as detailed in the installation on the right.

### DRYWALL INSTALLATION - 60 MINUTE DETAIL

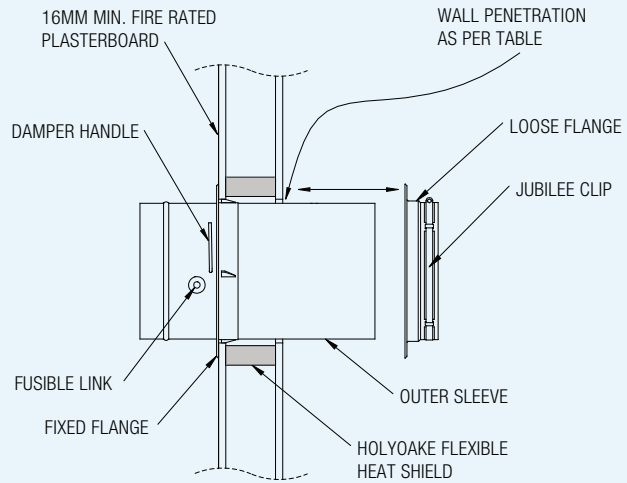

### TIMBER FRAMED FLOOR INSTALLATION\*\* - 60 MINUTE DETAIL

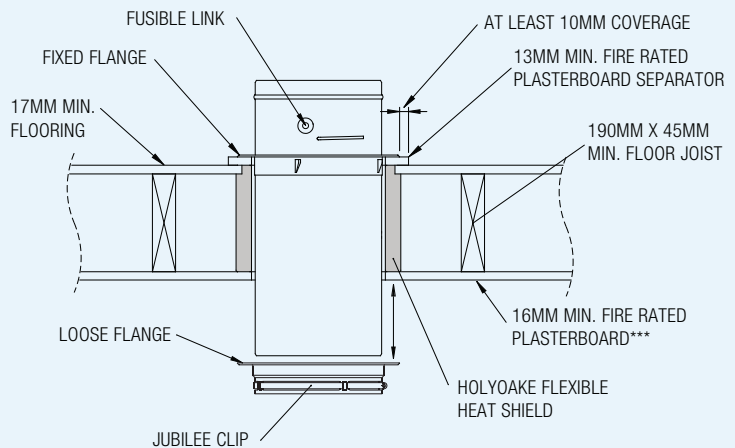

\*\*Ensure any connecting ductwork is self-supporting

\*\*\*Two Layers of 13mm min. fire rated plasterboard in Australia

## SPECIAL INSTALLATION OPTIONS

1. The LR damper is able to be installed such that the sleeve is separated from an adjacent construction element by a minimum distance of 35mm (as shown on the right).
2. Multiple LR dampers can be positioned with their sleeves separated by a minimum distance of 70mm.

**NOTE:** These options are applicable to both vertical and horizontal installations.

## DRYWALL AND TIMBER FRAMED FLOOR LINING INSTALLATION REQUIREMENTS

To determine the installation requirement of the LR damper use the following procedure:

1. Enter the wall or floor FRL/FRR that the damper will be fitted through in the table below.
2. Find the corresponding minimum distance(s) 'X' (depicted below in figure 1) between the dampers heat shield and the surrounding joists/ studs and noggings.
3. Use these two values to establish the required installation figure found below.



LR DAMPER  
PRODUCT INFORMATION AND  
INSTALLATION GUIDE

## INSTALLATION ADJACENT TO CONSTRUCTION ELEMENT

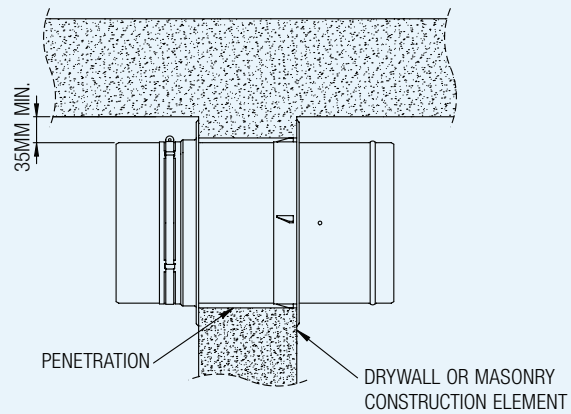

**EXAMPLE:** An LR 250 damper is to be placed in a timber framed floor with an FRL/FRR of 90/90/90, the dampers heat shield will be located 100mm away from one floor joist and over 145mm from the other joist and noggings.

1. From the table locate all floors with an FRL/FRR of 90/90/90.
2. Check the floors corresponding minimum distances (0mm and 145mm) against the actual distances (100mm and >145mm).
3. Figure 2 is therefore the obligatory installation, which requires one 16mm fire rated plasterboard lining on the joist located 100mm away from the heat shield.\*

\*Note that the remaining joist and noggings conform with figure 1 and so do not require an additional fire rated plasterboard lining.

FRL/FRR <sup>1</sup>			Corresponding Distance and Figures	
LR 100 - LR 250	LR 300 & LR 350	Wall or Floor	Minimum Distance (Xmm)	Installation Figure
-/60/-	-/60/-	-/60/60 or 60/60/60	0	1
-/90/-	-/90/-	-/90/90 or 90/90/90	0	2 <sup>2</sup>
		-/90/90 <sup>3</sup>	30	1
-/120/-	-	-/90/90 or 90/90/90	145	1
	-/90/-	-/120/120 or 120/120/120	0	2 <sup>4</sup>
	-	-/120/120 <sup>5</sup>	145	1

<sup>1</sup>Tested in accordance with AS 1530.4:2014

<sup>3</sup>Wall constructions only

<sup>5</sup>Steel framing walls only

<sup>2</sup>One layer of 16mm fire rated plasterboard lining

<sup>4</sup>Two layers of 16mm fire rated plasterboard lining

## ALTERNATIVE PENETRATION PLACEMENT DETAIL FOR WALLS AND FLOORS

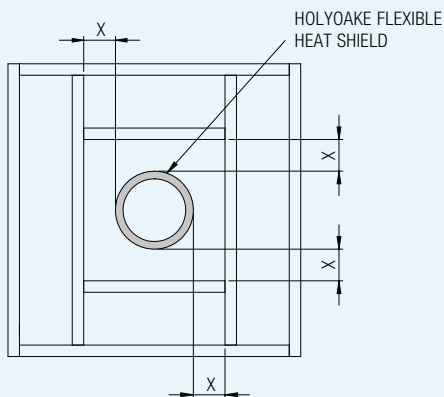

FIGURE 1: NO ADDITIONAL LINING REQUIRED

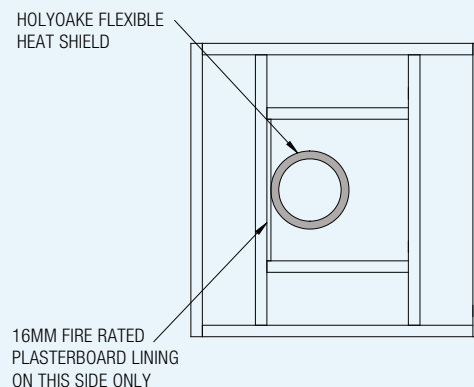

FIGURE 2: ADDITIONAL LINING REQUIRED WITHIN THIS COMPARTMENT ONLY

# LR FIRE DAMPER INSTALLATION FLOWCHART

## PENETRATION PREPARATION

To ensure the compliant installation of the LR fire damper, please follow the flowchart and steps below based on your specific job. Note that this preparation is only relevant for fire dampers and some penetrations will require additional lining (see chart below).

- STEP 1:** Begin with the fire barrier (separating element) the LR damper is being installed into.
- STEP 2:** Select the relevant separating elements required F.R.L./F.R.R.
- STEP 3:** Measure the anticipated distance from the heat shield to the nearest joist/stud or nogging.
- STEP 4:** Compare this value to the minimum distance allowed to a joist/stud or nogging.
- STEP 5:** Continue down the path to get the required number of 16mm fire rated plasterboard layers.
- STEP 6:** Attach the specified layers of fire rated plasterboard to that joist/stud or nogging along its entire length, in that cavity only. If the number of layers is not specified, no lining is required.
- STEP 7:** Repeat steps three to seven for all joists/studs and noggings in the penetrations cavity.
- STEP 8:** Proceed to the LR Installation Guide on the next page.

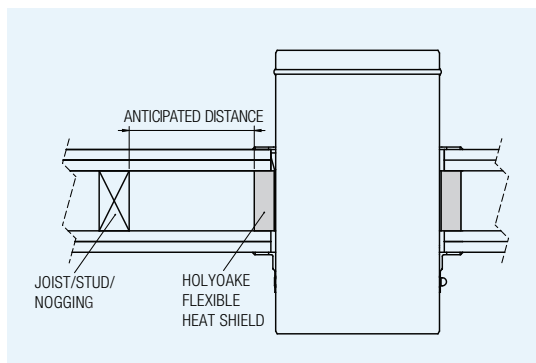
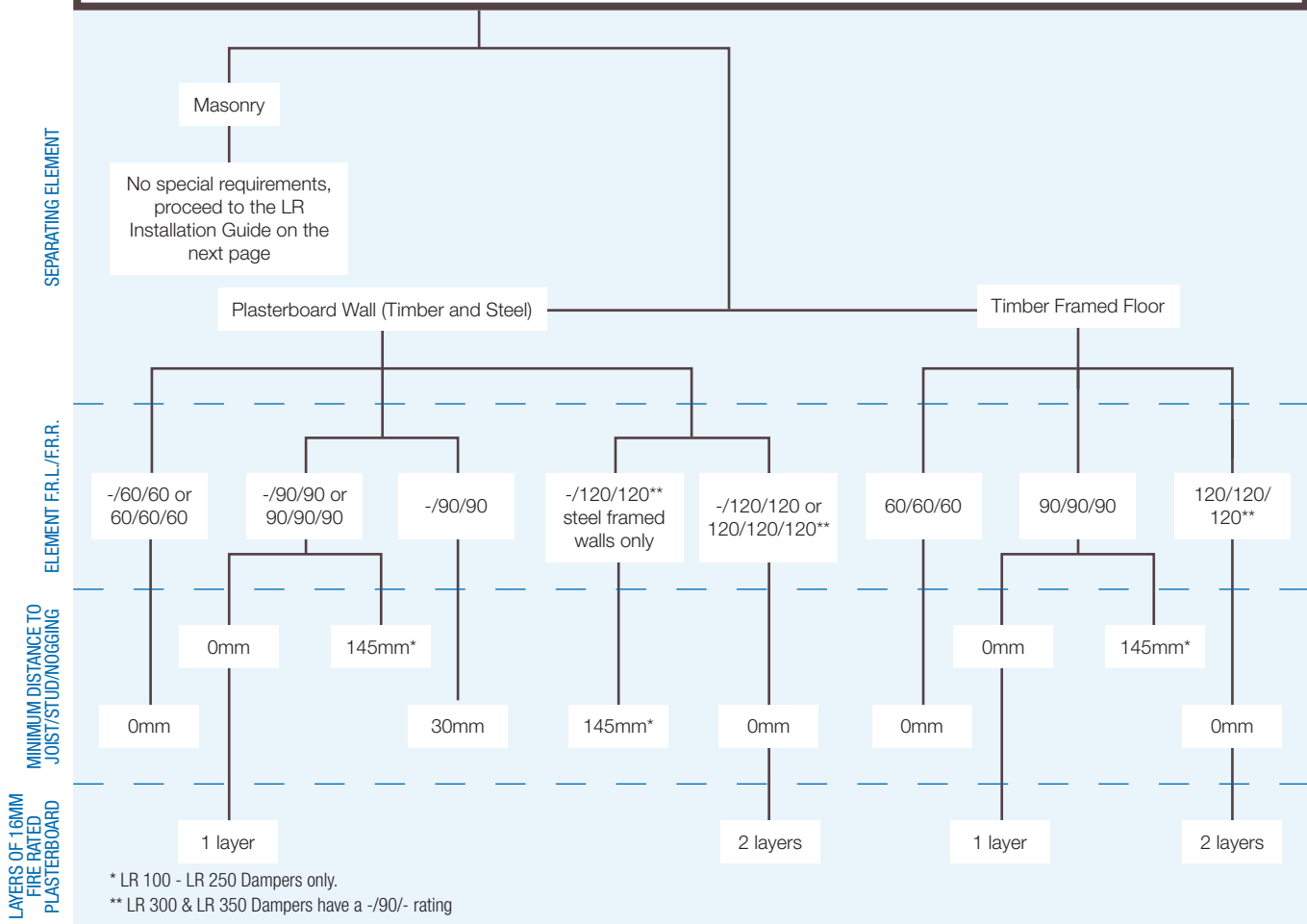

**EXAMPLE:** An LR 250 damper is to be placed in a plasterboard wall with an F.R.L./F.R.R. of 90/90/90, the dampers heat shield will be located 100mm away from one stud and over 145mm from the other stud and noggings. Using the flowchart, move down to 'Plasterboard Wall', locate all walls with an F.R.L./F.R.R. of 90/90/90, and check the wall's corresponding minimum distances (0mm and 145mm) against the anticipated distances (100mm and >145mm). This means the stud located 100mm away from the heat shield is classified under '0mm' and will require one layer of 16mm fire rated plasterboard. The other stud and noggings are classified under '145mm' and require no additional linings.

# LR FIRE DAMPER INSTALLATION GUIDE

## INSTALLATION STEPS

**STEP 1.** Cut penetration(s) as per Table 1 below.

**STEP 2.** Compress Holyoake flexible heat shield and insert into penetration (plasterboard applications only). Expand heat shield once inserted.

**STEP 3.** Remove loose flange from damper. Insert damper into penetration with fixed flange sitting against fire barrier.

**STEP 4.** Slide loose flange (high temperature seal facing wall) onto the damper and tighten jubilee clip with screwdriver.

**STEP 5.** Using damper handle and fusible link, test damper operation and then set blade to required position.

Table 1: Penetration Sizing

Damper Size (Ø)	Penetration (mm)	Flooring Penetration (mm)
LR100/125	130 - 138	160 - 180
LR 150	155 - 163	185 - 205
LR 200	205 - 213	235 - 255
LR 250	255 - 263	285 - 305
LR 300	305 - 313	335 - 355
LR 350	355 - 363	385 - 405

**Blue arrows:** indicate progression between steps of the installation.

**Black arrows:** illustrate directional movement required by the objects.

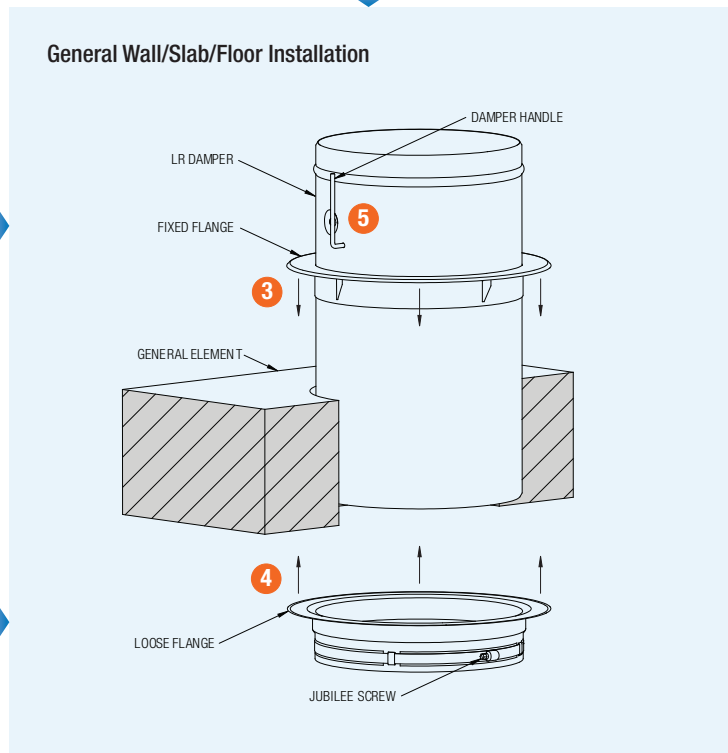
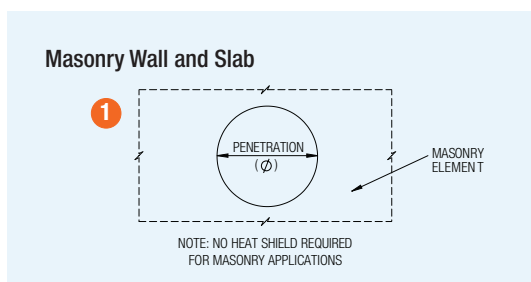
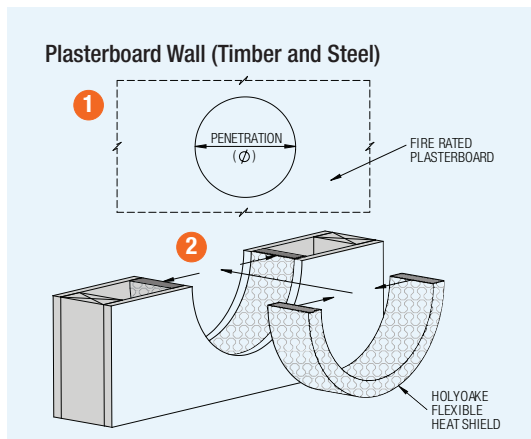
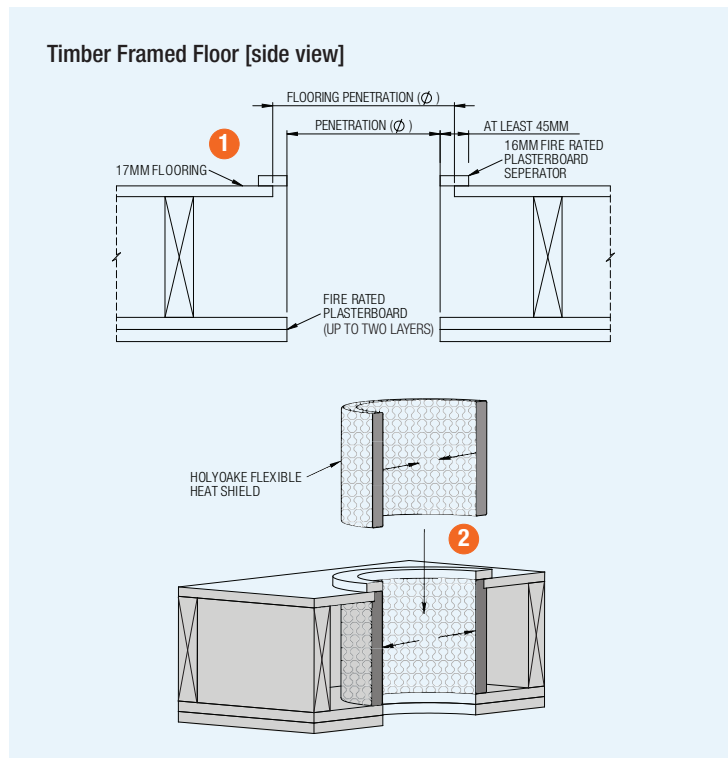

# Performance Data

## LR DAMPER PRESSURE DROP

Pressure Drop (Pa)						
FLOW RATE (L/S)	LR125	LR150	LR200	LR250	LR300	LR350
20	3.5	1.1	0.2	<0.1	<0.1	<0.1
40	13.7	4.5	0.9	0.1	<0.1	<0.1
41	15.0	4.9	1.0	0.1	0.1	0.1
60	32.0	10.7	2.1	0.3	0.2	0.2
71	45.2	15.0	2.9	0.8	0.2	0.2
80	57.5	19.0	3.7	1.1	0.3	0.2
100	90.5	29.8	5.9	1.8	0.6	0.3
120	129	42.6	8.5	2.6	0.9	0.4
140	176.3	58.6	11.6	3.6	1.2	0.5
160		76.2	15.0	4.8	1.7	0.7
180		96.7	18.9	6.1	2.3	1.0
200		118.0	23.3	7.4	2.9	1.2
240			34.0	11.0	4.2	1.7
273			46.1	15.0	5.5	2.3
280			60.6	15.1	5.8	2.4
320				19.6	7.6	3.2
360				24.8	9.7	4.1
400				30.8	11.9	5.1
440				37.2	14.5	6.2
446				39.4	15.0	6.6
480				44.2	17.4	7.4
520				51.9	20.4	9.0
560					23.8	10.3
600					27.3	11.7
640					31.0	13.6
653					32.4	15.0
680					35.1	15.8
720					39.3	17.8
760						19.9
800						22.0
840						24.3
880						26.7
920						29.1
960						31.7
1000						34.4

As per the requirements of Section J of Australia's NCC - Volume One, and New Zealand's Building Code - Energy Efficiency H1/MM3, the 15Pa pressure drop flow rate has been denoted in orange.

## LR DAMPER PRODUCT GUIDE

Guide Product Weights			
LR Model	Weight (Kg)	LR Model	Weight (Kg)
LR100	1.6	LR250	2.8
LR125	1.4	LR300	3.8
LR150	1.65	LR350	4.7
LR200	2.25	LR Heatshield	0.35



# Product Ordering Key & Suggested Specifications

<b>LR</b>	<b>-</b>	<b>100</b>	<b>-</b>	<b>D</b>	<b>-</b>	<b>100</b>	<b>-</b>	<b>F</b>	<b>-</b>	<b>24V</b>	<b>-</b>	<b>EXT</b>
		<b>125</b>		<b>M</b>		<b>150</b>		<b>FS</b>		<b>230V</b>		
		<b>150</b>				<b>230</b>		<b>S</b>				
		<b>200</b>										
		<b>250</b>										
		<b>300</b>										
		<b>350</b>										
<b>Model</b>		<b>Size (diameter)</b>		<b>Structure</b> <i>D = drywall*</i> <i>M = masonry</i>		<b>Heat Shield (width)</b> <i>drywall*</i> <i>only</i>		<b>Damper Type</b> <i>F = fire</i> <i>FS = fire-smoke</i> <i>S = smoke</i>		<b>Actuator Supply</b> <i>fire-smoke and smoke only</i>		<b>Sleeve (length)**</b> <i>standard (default)</i> <i>EXT = extended (optional)</i>

Holyoake LR 100 - LR 250 fire and smoke dampers have a four hour rating in a masonry wall/floor and a two hour rating in a steel/timber framed wall, timber framed floor, and Hebel system with a smoke leakage of less than 50l/s.

Holyoake LR 300 and LR 350 fire and smoke dampers have a 90 minute rating in a masonry wall/floor, steel/timber framed wall, timber framed floor, and Hebel system with a smoke leakage of less than 50l/s.

The damper is certified to AS 1530.4 - 2014 Section 11 (ducted damper installations), AS 1530.7 - 2007, as well as the requirements of the AS 1682 - 2015 series. The rating given by this certification applies to fires on both sides of a fire wall and the underside of a fire rated floor. Holyoake LR fire dampers contain a fusible link that releases and allows the damper to close upon reaching 71°C. An external lockable handle is included as standard that can be used to position the damper blade to provide volume control. Holyoake LR fire and smoke dampers contain an electro-thermal link that releases and allows the damper to close upon reaching 72°C. An actuator is included as standard that can be signalled to close by a building management system (BMS).

LR fire and smoke dampers should be annually tested as determined by AS 1851 - 2012 (Section 13): Routine service of fire protection systems and equipment.

LR fire and smoke dampers shall be Holyoake Series LR F, LR FS, or LR S and shall be manufactured and supplied by Price Holyoake.

\* Drywall represents all plasterboard applications including timber framed floors.

\*\* Standard sleeve length suits fire barriers up to 190mm; extended sleeve length suits fire barriers up to 295mm.

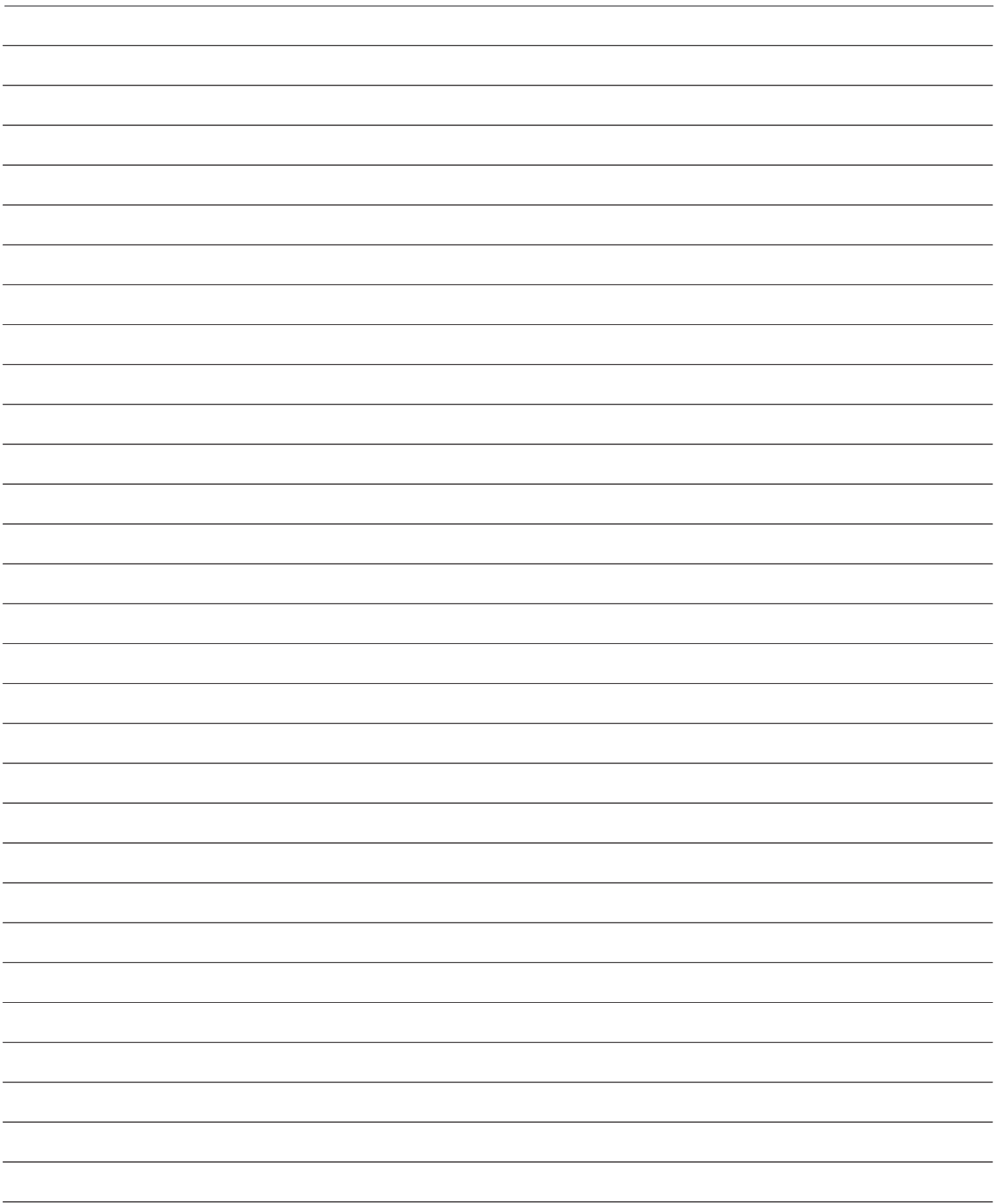

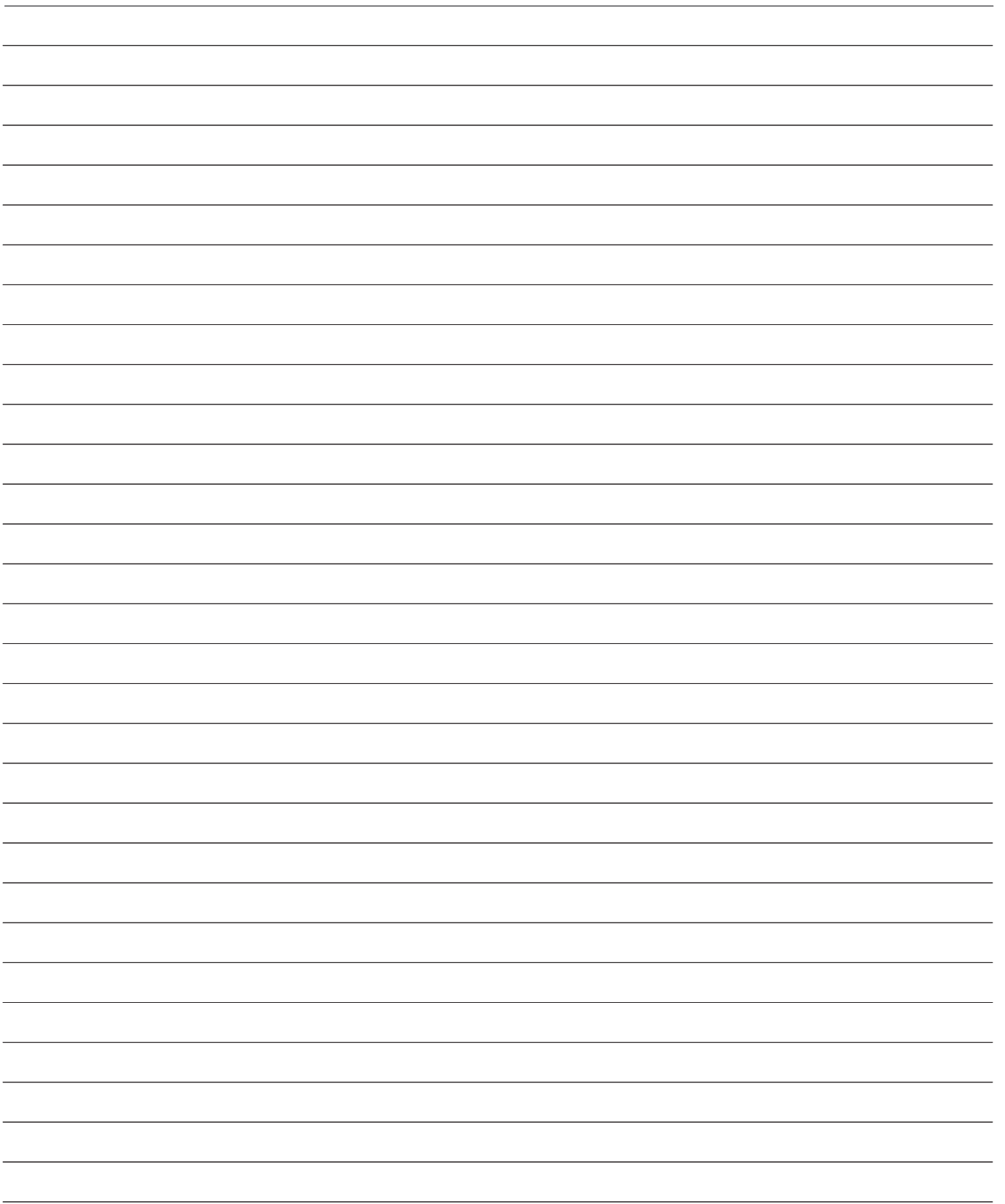

## NEW ZEALAND

### Auckland Office & Factory

67-69 Greenmount Drive, East Tamaki  
Auckland 2013 New Zealand  
PO Box 58-548 Botany  
Manukau 2163 Auckland NZ  
Tel +64 9 274 4144  
Email auckland@holyoake.com

### Wellington Office & Factory

89 Main Road, Tawa  
Wellington 5028 New Zealand  
PO Box 51-038 Tawa  
Wellington 5249 New Zealand  
Tel +64 4 232 2722  
Email wellington@holyoake.com

### Christchurch Office & Factory

27 Waller Terrace, Addington  
Christchurch 8011 New Zealand  
PO Box 632 Christchurch Mail Centre  
Christchurch 8140 New Zealand  
Tel +64 3 366 6545  
Email christchurch@holyoake.com

## AUSTRALIA

### Melbourne Office & Factory

95 Redwood Drive, Dingley  
Victoria 3172 Australia  
PO Box 195, Braeside  
Victoria 3195 Australia  
Tel +61 3 9551 5022  
Email melbourne@holyoake.com

### Sydney Office & Factory

12 Butterfield Street, Blacktown  
NSW 2148 Australia  
Tel +61 2 9620 9555  
Email sydney@holyoake.com

### Brisbane Office & Factory

5 Program Street, Yatala  
Queensland 4207 Australia  
PO Box 6061 Yatala  
Queensland 4207 Australia  
Tel +61 7 3807 7111  
Email brisbane@holyoake.com

### Adelaide Office & Factory

86 Hardys Road, Torrensville  
Adelaide SA 5031 Australia  
Tel +61 8 8354 1580  
Email adelaide@holyoake.com

### Perth Office

Level 28 AMP Tower  
140 St Georges Terrace  
Perth WA 6000 Australia  
Tel +61 8 8354 1580  
Email perth@holyoake.com