

Fan Assisted VAV Control Assemblies

Holyoake fan assisted VAV terminals, both **Parallel** and **Series** types, have been designed to provide optimum performance with robust construction, minimum noise and maximum reliability.

Construction is rugged galvanised steel with non-woven acoustic polyester insulation, minimising casing radiated and airborne noise.

Access for service has been given high priority. The complete bottom panel has been designed for removal without affecting the mounting of any internal components.

Fan and Motor. A forward curved fan assembly is used and is directly driven by a 3 speed single phase motor. Housed in a semi rigid high density casing. A 3 speed switch is provided as standard.

Infinite Speed Control is achieved by an optional variable speed controller with minimum voltage adjustment to guard against stalling at low speeds. The speed controller is used in conjunction with the most suitable motor speed winding, connections for which, together with the controller, are located on a small panel.

Accurate Velocity Control of primary air is achieved, where the selected controls allow, by the use of Holyoake PDI averaging (multi-point) velocity sensors, which tolerate up to 90° hard bend inlet conditions with little change in accuracy. These sensors have been shown by independent tests in straight duct to be consistent, one to another, within 1%. Their flow measurement accuracy is within $\pm 2.5\%$ in straight duct and $\pm 5\%$ after a hard 90° bend. Actual flow may be measured independently of controls by micromanometer, or magnahelic, using the capped Tees provided.

* Note that velocities below 1.8 m/s generate ΔP 's below 3 Pa and instrument sensitivity may preclude measurement at these levels.

Secondary Air Filters are furnished with 'EU2' washable type media as standard.

Controls may be of any specified make and type to match any B.M.S. This normally implies compatible D.D.C. However, where a B.M.S. is not involved, or where communication with it can be kept to a limited level, Electronic Analogue controls offer a lower cost alternative, with all or most of the features offered by D.D.C. Pneumatic control is also available.

Guide Product Weights

Case Size	Description	Approximate Weight in Kg.
350	HFCP Fan Assisted - Parallel (Inc Square Flange)	20
350	HFCS Fan Assisted - Series (Inc Square Flange)	20

Model HFCP

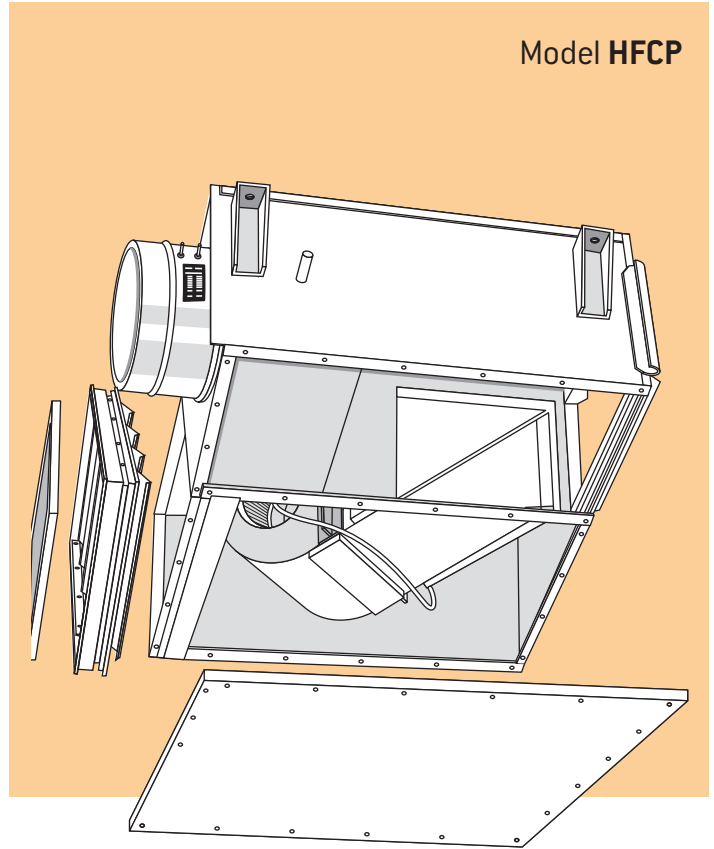

Model HFCS

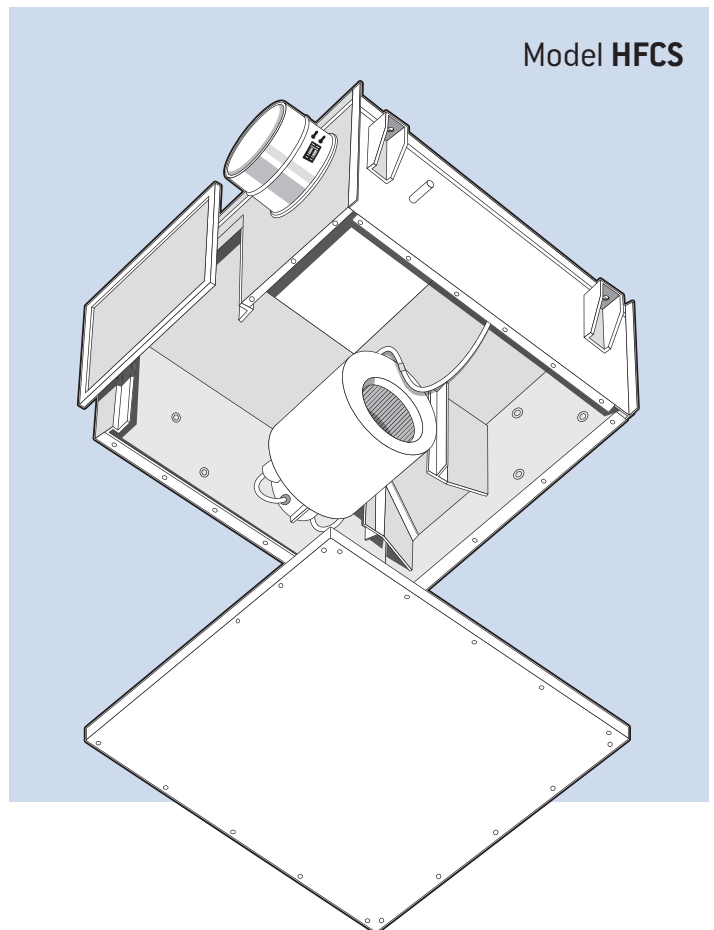

HFC – Fan Assisted VAV Terminals

Fan assisted VAV terminals offer features which may be desirable where load conditions can not be entirely met by primary only VAV, without compromising either air movement standards, or running costs. With conventional primary air temperature systems, they are more likely to be found in the perimeter zones, where load fluctuations and reversals occur, or in stable low load interior zones where air circulation requirements need boosting above those required to match cooling loads. Lower primary air temperatures, such as those encountered with ice storage plants, would be likely to find fan assisted units essential, in order to provide adequate diffuser performance, offsetting the effects of a down sized air system. The selection of any fan assisted unit should always be done with the knowledge that it is a piece of mechanical equipment above the occupied area. It needs full voltage electrical power and it will require regular access for filter replacement. Like any piece of mechanical equipment, it does have the potential for noise, or failure, however carefully it is made and installed.

Applications which need fan assisted units will be those which must benefit from the following features:

- a. Increased air movement during low cooling, or re-heat periods.
- b. Full or partial heating by waste heat accumulated in the ceiling space, significantly reducing heating operating cost.
- c. Primary air turn-down to zero, or very low minimum ventilation requirements, with room air velocities maintained at full primary air levels or greater, as required.
- d. Independent operation as a fan/heater, either with, or without, electric, or hot water heating coils.
- e. Retrofit to replace constant, or variable volume dual duct units.

All of the above must be achievable without compromising minimum ventilation rates and indoor air quality.

Two Basic Types

The two basic types are **Parallel** (variable flow), or **Series** (constant flow). Both contain a primary air variable volume valve and re-circulation fan, and both take secondary air from the ceiling space.

The illustrations, figures 1 and 2, show the different configuration of the two types.

Figure 1.

In the **Parallel** unit, primary air enters the valve and flows directly into the distribution duct. At reduced volumes, the fan is called into operation causing secondary air to flow **Parallel** to the primary air, mixing with it before entering the distribution duct. The fan therefore, runs intermittently.

Figure 2.

In the **Series** units, the primary air enters the valve, mixes with the secondary (ceiling) air, and continues in **Series**, through the fan into the distribution duct. The fan runs continuously while air conditioning is required.

Comparisons between the two are outlined on the following pages.

Due to a policy of continuous development and improvement the right is reserved to supply products which may differ slightly from those illustrated and described in this publication.

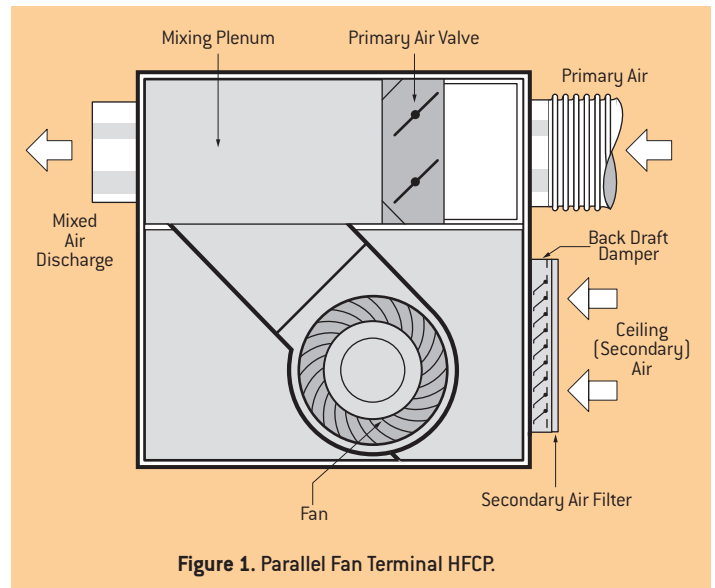

Figure 1. Parallel Fan Terminal HFCP.

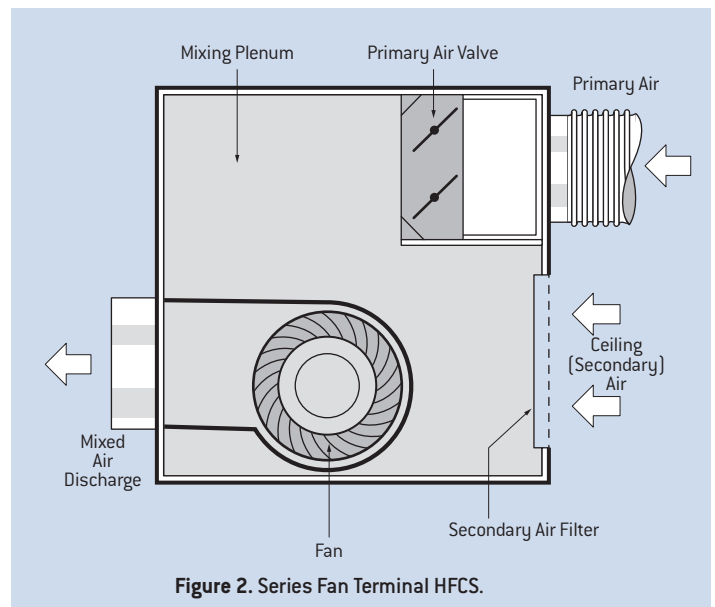

Figure 2. Series Fan Terminal HFCS.

GENERAL COMPARISON OF TYPES			
Para. Ref.	Item	Parallel	Series
1	Primary air inlet pressure requirement	higher	lower
2	Fan air flow and discharge pressure	lower	higher
2	Terminal running cost	lower	higher
2	Noise type	intermittent	constant
2	Noise level	lower	higher
3	Diffuser maximum airflow	larger	smaller
4	Precaution against backward rotation	none	some
5	Suitable pressure independent	yes	no
6	Main plant running cost at zone part load	lower	higher
7	Loss of service if secondary fan fails	heating	all
•	Filter cleaning	less	more

This table relates to Paragraphs 1-7 of System Considerations on page 285G.

System Considerations

1. Although power savings at the primary fan can be achieved by both types, they do not have the same inlet static pressure requirements. Like primary only VAV terminals, **Parallel** units require sufficient static pressure to overcome the open valve resistance, typically about 40 Pa, as well as the discharge duct and diffusers of around 60 Pa. i.e. a total of 100 Pa.

Series units can be supplied with primary air at a static pressure only marginally above ambient, typically around 40 Pa, since the fan power, which is always available, covers the down stream requirements.

2. Air Volumes handled by the fan for **Parallel** units are usually between 50% and 65% of full primary air, generally using the same fan operating at a lower speed and therefore, lower operating noise level and running cost. The secondary fan is also selected for the lower discharge static pressure required by reduced air flow.

Consideration by the designer should be given to whether it is more desirable to have a quieter, but variable noise level.

Air volumes handled by the fan for the same load are greater for the **Series** unit at 100% full primary air.

Noise levels are higher, but constant on these units.

3. When sizing the discharge duct and diffusers, it should be noted that larger total air quantities and the consequent increase in friction if duct sizes are not increased, are likely to occur with **Parallel** units when the fan begins to operate while primary air is turned down to anything more than 30%. It is likely that the discharge duct and diffusers will need to be sized for a maximum air flow of the combined primary (say 60%) and secondary (say 65%) i.e. 125% of full primary. The effect of increased resistance on the fan will probably reduce secondary flow, but it is still likely that discharge air flows will be 120% of full primary air. The effect of this should be taken into account when selecting diffusers and when determining discharge pressure requirements for the fan assisted terminal.

4. As a precaution against the possibility of backward fan rotation at start up of the fan terminal, **Series** terminal fans should be interlocked so that they are energised before the main fan which could otherwise cause back flow of primary air into the ceiling plenum. It would be necessary however, for the secondary fan motor to reach almost synchronous speed in reverse at start up to cause damage, so this precaution should be evaluated in the context of the main air system.

5. **Series** type terminal fans should have speeds adjusted to match (or be slightly greater than) full primary air flow. Over-pressurising the unit with primary air causes lost energy as it spills into the ceiling void. For this reason **Series type units should not be used in pressure dependant systems.**

6. For all practical considerations, non assisted, or **Parallel** units, would have lower running costs compared with the equivalent **Series** type units, which continuously draw heat from the ceiling space. This adds to the occupied zone sensible cooling load, particularly at partial load conditions, increasing the primary air requirement.

7. In a **Parallel** system, failure of the assembly fan, or its power supply, leaves the primary (and ventilation) air supply unaffected, so that occupants notice no discomfort during full, or partial cooling demand. Only heating demands cannot be met.

Such a failure in a **Series** system, completely and immediately deprives the zone of air conditioning while primary air, flowing at maximum levels due to the unsatisfied room stat, is ineffectively spilled into the ceiling void.

Economics

An energy audit of a fan assisted system must include the effects on central plant heating and refrigeration capacity. The main effects of the choice between **Parallel** and **Series** units however, can be shown by considering just the main fan and the terminals. Energy used by terminal fans depends upon operating hours and fan loading.

Parallel fans run only at partial cooling load and for heating for periods ranging between 500 and 2,000 hours per annum.

Series units run continuously for rather more than occupied hours, ranging between 3,000 and 4,000 hours per annum.

Parallel fans typically handle 50% to 65% of primary air and operate against a lower external static pressure for the same downstream duct.

Series fans must handle the full flow, plus a small margin.

For example, a **Parallel** fan may be selected for 0.300 m³/s at 19 Pa external.

A **Series** fan selected for 0.500 m³/s in the same duct system operates against 50 Pa.

Comparative operating costs can be illustrated by the following example, using power at 25¢ per kWh.

	Parallel	Series
Air flow m ³ /s	0.300	0.500
Watts	145	390
Operating hours	2,000	4,000
kWh P.A.	290	1,560
Annual cost	\$72.50	\$390.00

Estimated savings on the central fan could be as shown in the following example, which assumes a total air flow of 5.600 m³/s.

	Parallel	Series
Discharge Static Pressure, Pa	1,000	940
kW	9.325	8.206
Annual Power cost over 4,000 hours at 25¢ per kWh	\$9,325	\$8,206
Annual Main fan saving for Series units		\$1,119

The above combined would represent a system of say 15 fan boxes and their main supply fan.

The annual running cost of the **Parallel** system would be, for this example only, **\$10,412.25.**

For a **Series** system, on the same basis, annual running cost would be **\$14,055.55.**

Capital cost of a **Parallel** unit is slightly higher than the equivalent **Series** assembly, due mainly to the need for a back draft damper. For the sizes in the foregoing example, this difference is about \$165 per assembly.

The first year of operation would favour the **Parallel** unit by an energy cost of \$3,643.05, almost exactly cancelling the first cost penalty. From then on the difference of \$3,643.05, each year is the cost which can probably be identified with noise type preference.

None of the above considers the effect with **Series** fans of unwanted reheat at part load, the effect of any over supply of secondary air at full cooling, or the possibility of ceiling pressurisation with treated primary air in the event of a fault.

Control of Fan Assisted VAV Terminals

With the exception of fan operation, control sequences for fan assisted units are the same as those for non-assisted assemblies.

- These diagrams are for pressure independent applications. Pressure dependent options are available for areas with stable loads, with low velocity and pressure. Their design should minimise inlet pressure fluctuations. These would benefit from primary air temperature re-set.
- **Parallel** units energise the fan at the correct point in the zone sequence, via a P.E. switch (pneumatic), or a control signal (electronic), or through a relay, from a local 240V AC power supply.
- The illustration below shows the secondary fan is set to provide 60% of the primary air flow and function only when it falls to 50%. Air quantities are variable. Cooling only is shown, with reheat from ceiling recirculation.

Parallel HFCP

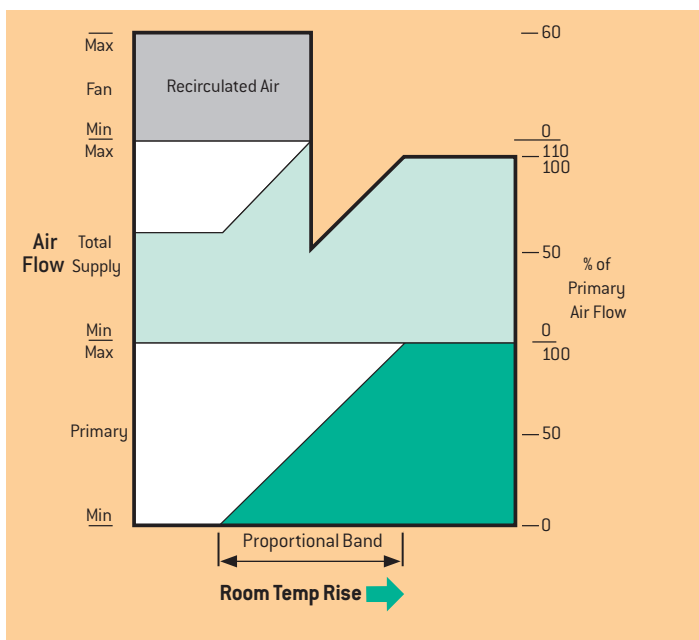

- Operating as a single duct VAV terminal until primary air flow reduces to 50%. Then the secondary fan starts, boosting the total supply air to about 110% of primary. As the temperature falls, primary air reduces to preset minimum and the secondary fan provides the total air flow, at approximately 60%.

Option

- As an option Holyoake fan assisted units can be furnished with one metre of electrical flex from the fan speed selector / speed controller panel, terminating in a three pin plug. Local power wiring should terminate in a matching socket.

PRIMARY VALVE INLET DIAMETER mm	MAX. FLOW m ³ /s	SMALLEST CASING SIZE
150	0.225	A1
200	0.500	A2
250	0.650	B
300	1.000	C
300	1.000	D*
350	1.600	E
400	1.900	F

* Casing size D* is a low profile size 300 inlet diameter which uses a double fan deck. Casing size E and F also have double fan decks.

- **Series** units require either a remotely switched relay, or direct 240V AC power to control the fan in the correct sequence with the main fan.
- The illustration below shows a 5% mismatch of fan and primary air. This could raise general room air movement, or guard against primary air loss to the ceiling. This mismatch can be reduced, or eliminated, but voltage fluctuations could alter delivered fan air flow. The fan is set to provide slightly more air than maximum primary in this example to prevent loss of primary air to the ceiling void. Fan and primary air quantities are essentially the same. Cooling only is shown, with reheat from ceiling air re-circulation. The primary valve functions as a single duct terminal, with pressure independent, constant maximum, primary air flow when room temperature rises to and above, the top end of the room stat setting.

Series HFCS

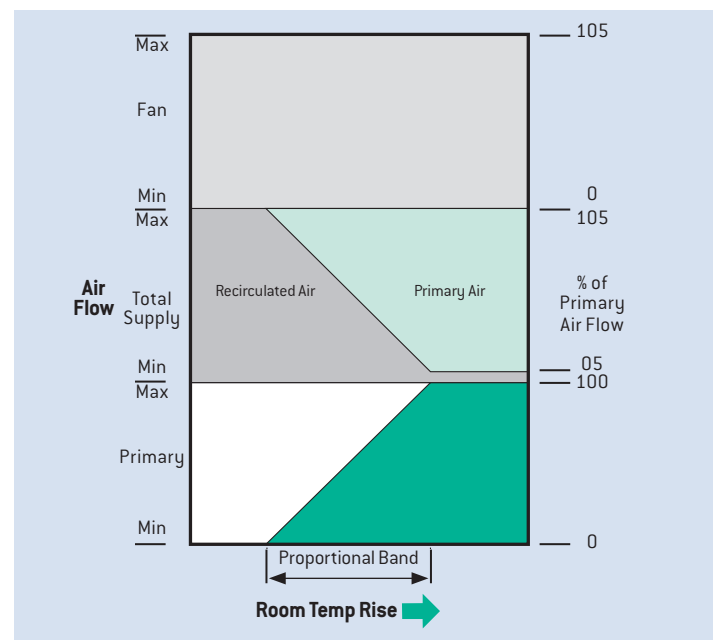

- A fall in temperature gradually reduces primary air flow to its preset minimum, or zero and maintains this irrespective of upstream pressure. The secondary fan provides warm ceiling air to provide a constant flow and supplement the reduced primary air.
- The two diagrams shown are typical, without additional heating. Both types can be furnished with auxiliary electric, or hot water reheat.

Selection Procedure

1. Select primary air valve inlet size, from table opposite.
2. Determine whether **Parallel** or **Series** operation. Refer to 'Type' description and 'System Considerations' on previous pages, 283G - 285G.
3. Identify smallest casing size to suit the chosen air valve, from table opposite.
4. Establish secondary air flow (generally 50-65% **Parallel**, or 100% **Series** - of full primary air).
5. Check that fan capacity for selected casing is adequate against design static pressure of discharge duct and outlets. If not check next larger casing size.
6. Select heater (if required in addition to heat from ceiling void). See pages 273G - 274G (**HW coils**) or 275G (**electric**).

Fan Assisted VAV Control Assemblies

The Holyoake model HFCS is a series type fan-assisted VAV assembly, offering a robust unitary construction, which:-

- Provides continuous fan operation.
- Reduces airborne and radiated noise levels to a minimum.
- Offers compatibility with all accessories available for the HCV series.

All HFCS terminals are furnished with:

- Secondary air inlet filter.
- Two, or three speed fan motor.
- Solid state speed controller.
- Access for motor/rotor service, or replacement, without removal of the assembly.
- Fully removable bottom panel.

Construction

The primary air element is identical to the HCV series air valve and mechanism, with extruded aluminium blades mounted in a steel liner, forming a high pressure chamber for ducted inlet air. A forward curved fan, directly driven by a multi-speed, resilient mounted single phase P.S.C. motor, is rigidly supported within the casing. All components are housed in an acoustically lined steel enclosure.

Inner & Outer Casing: 0.75 mm galvanised steel with 0.55 mm inlet neck.

Insulation: 25 mm black non-woven polyester acoustic insulation.

Control Damper: 6063-T5 extruded aluminium frame and blades on bright anodised aluminium axles. Sizes 100 to 200 double blade, larger sizes multi-blade opposed action.

Bearings: Acetal

Filter: 'EU2' washable type filter media, fitted to the front of Hot Water Coil, or Attenuator, if applicable.

Fan: Forward curved. For fan performance curves contact your local Holyoake branch.

Accessories

- One, or two row H.W. heating coil.
- Electric heater.*
- Inlet attenuator.
- Outlet attenuator.*
- Multiple dampered outlet adapter.*
- Round outlet adapter.*

[* Refer to details in HCV section].

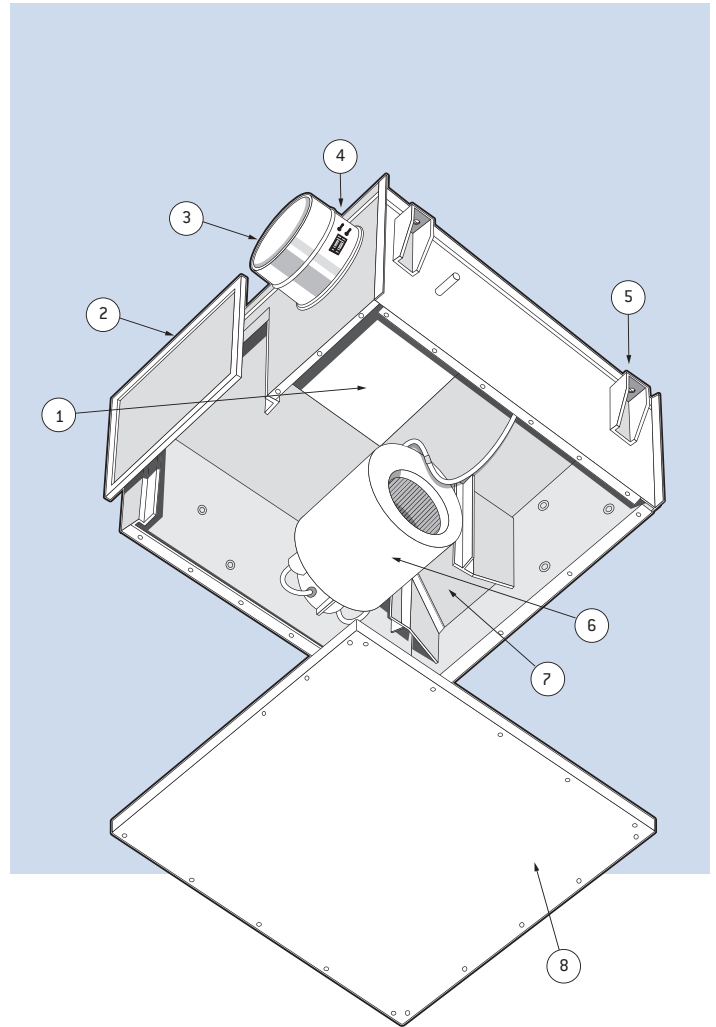

View Of Model HFCS From Below With Bottom Panel Removed.

1. Primary air control valve assembly.
2. Secondary air filter (lift and drop fixing).
3. Primary air inlet.
4. Averaging velocity sensor with capped Tees for independent flow measurement.
5. Suspension brackets.
6. Secondary air fan and direct drive motor.
7. Discharge duct with slip and drive connections.
8. Removable bottom panel.

Model: Number Key

HFCS	X	X	X	X	X	INLET:	XXX	X
	CONTROLLER MAKE	CONTROL TYPE AND ACTION.	HEATING COIL	ATTENUATOR	OUTLET ADAPTER	HCV SIZE (PRIMARY AIR)		CASING SIZE
Series	1 Siemens	0 None	0 None	0 None	0 None	Inlet Diameter in mm.		
Fan Assisted VAV Assembly	2 Honeywell	1 Pneumatic	1 1 Row HW	1 Outlet Attenuator.	1 Round (undampered)	100-125-150		A1
	3 Alerton	2 Electronic.	2 2 Row HW	2 Inlet Attenuator.	2 Multiple (dampered)	175-200-225		A2
	4 Belimo		3 Electric**	3 Both.	9 Special	250		B
	5 KMC		9 Special.			300		C
	6 Delta					300*		D*
	7 Schneider Electric					350		E
	8 CSI					400		F
	9 Other Manufacturers (Please Specify).							

Casing size D is a low profile size 300 inlet diameter which uses a double fan deck. Casing size E and F also have double fan decks."

** Separately schedule voltage, phases, kW & stages.

HFC – Fan Assisted VAV (Series)

Model: HFCS

Dimensions

HFCS 100-300 Dimensions

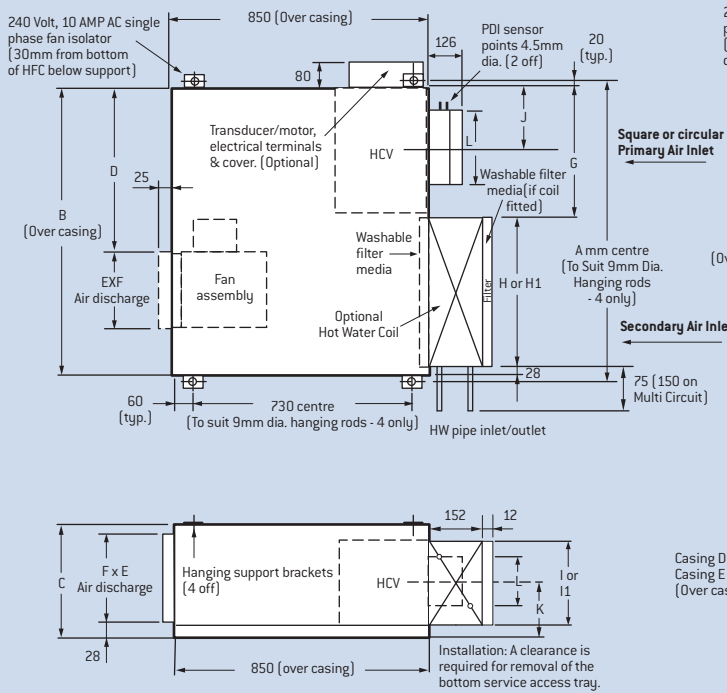

HFCS 300/350/400 Dimensions

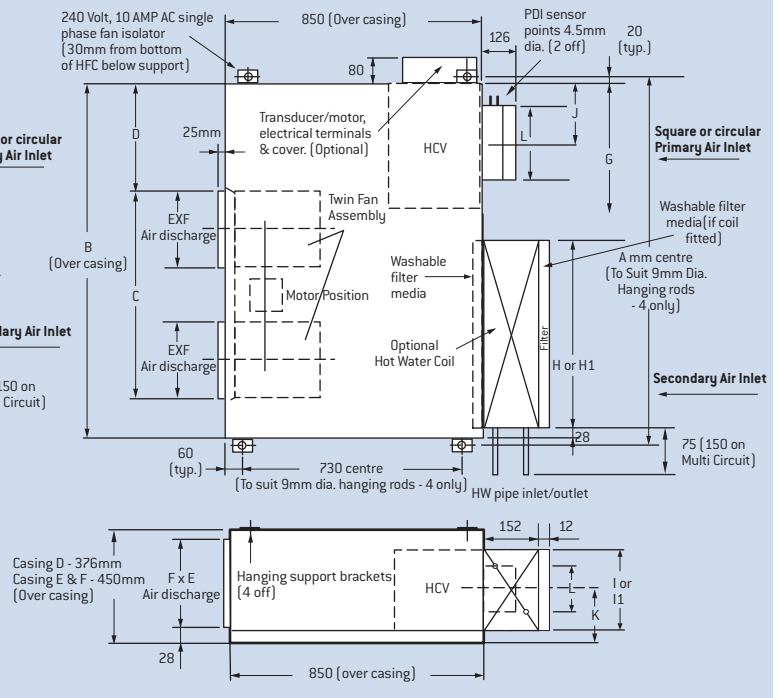

Casing Size		A	B	C	D	E	F	G	H	H1	I	I1	J	K	L
100-125-150	A1	865	825	376	413	254	166	315	482	286	316	223	145	138	100-125-150
175-200-225	A2	865	825	376	413	254	166	315	482	286	316	286	145	174	175-200-225
250	B	1015	975	376	553	254	166	431	516	428	316	286	216	174	250
300	C	990	950	450	486	300	262	431	491	428	390	369	216	210	300
300	D*	1365	1325	706	455	248	166	431	866	428	316	369	216	186	300
350	E	1545	1505	826	503	297	185	515	962	512	390	398	258	225	350
400	F	1770	1730	934	620	297	185	640	1062	636	390	442	320	222	400

NOTE: Casing sizes D, E and F have double fan decks.

* Casing size D is a low profile size 300 inlet diameter which uses a double fan deck

x H1 and I1 dimensions applicable when Hot Water Coils fitted.

Accessories

- Electric heater - see HCV section pages 275G.
- Hot water coil. For selection and dimensional information on H.W. coils and attenuators, refer to page 291G.
- Inlet attenuator type ST2, with 2 row core. Item 3 shows location of ST2 when a hot water coil is fitted.
- Inlet attenuator type ST4 is a double banked assembly, consisting of a 4 row core, 400mm deep.
- Discharge attenuator. See page 265G.

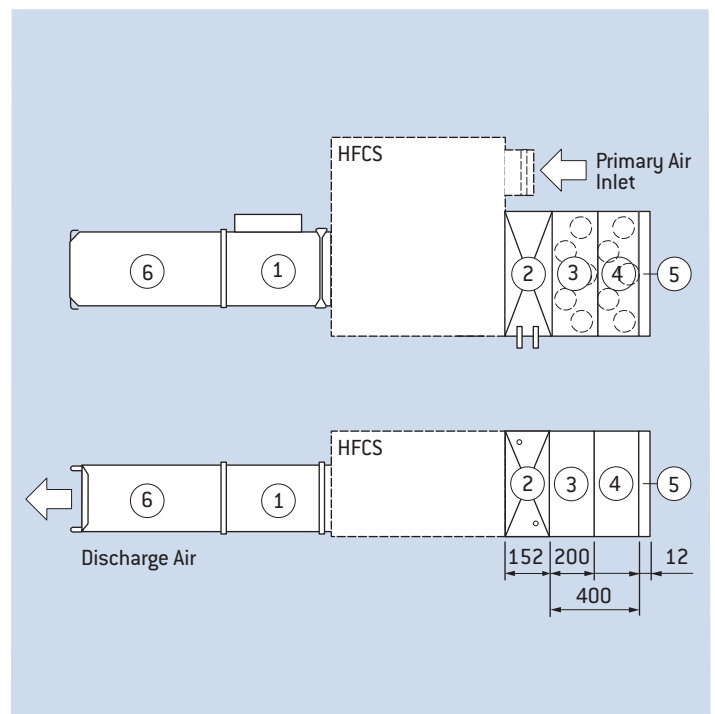

Due to a policy of continuous development and improvement the right is reserved to supply products which may differ slightly from those illustrated and described in this publication.

Electrical Heater Boxes & VAV Electric Heater Box Assemblies

Holyoake electric heater packs are designed as accessories for either single duct VAV terminals, or fan assisted VAV assemblies. They comply with AS 1668.1 - 1998, section 2.6 and with AS/NZS 3102:2002.

Installers must take special consideration of AS/NZS 3102, clause 7.2, Interlocking of supply to heater unit and blower motor and clause 7.3, Devices to prevent overheating.

General

Maximum heater capacities have been established in consideration of both likely maximum need and physical size of the element bundle. The latter is in turn dictated by the allowable watt density of the elements, which governs the maximum sheath temperature. The standard sizes listed here as finned tubular elements, achieve “black heat” (sheath temperature 400°C) in air moving across the element surface at a velocity of 1 m/s, i.e. “still air” with the velocity created only by the temperature of the element itself. These capacities meet the requirements of AS 1668.

Standard Features

1. Duct casing 0.75mm galv. steel.
2. Non combustible heat screen liner.
3. Finned elements comprising of 304 stainless steel fins on 309S stainless steel tubes.
4. Slip and drive duct connections (drive connections on all four sides are available on request).

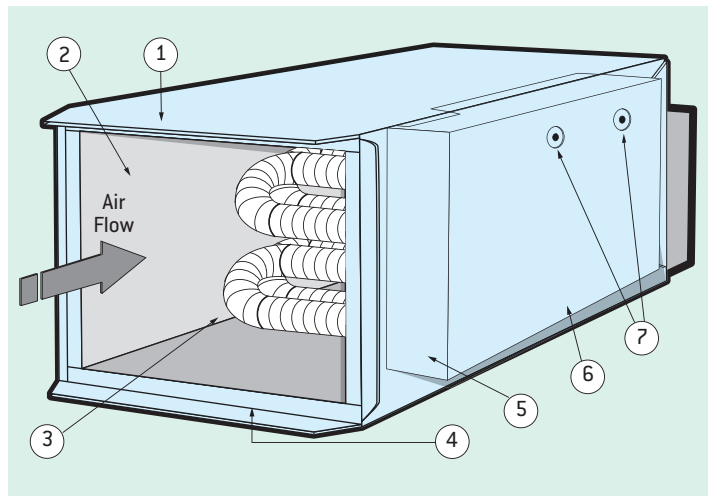

5. Electrical box containing heater terminals, contactors (or power relays), over-temp stat and wiring to terminal block. If required an isolating switch may be added.
6. Cover held by screws accessible from the sides.
7. Manual reset over-temp stats.

Option

Solid state control for pulsed heater control.

Heater Section Only

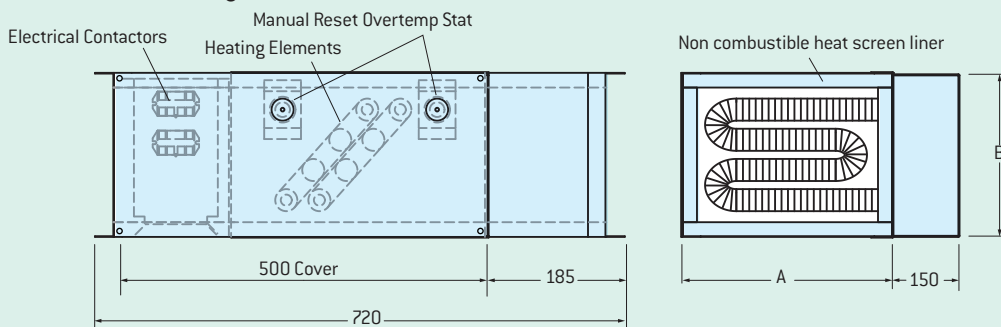

VAV with Electric Heater*

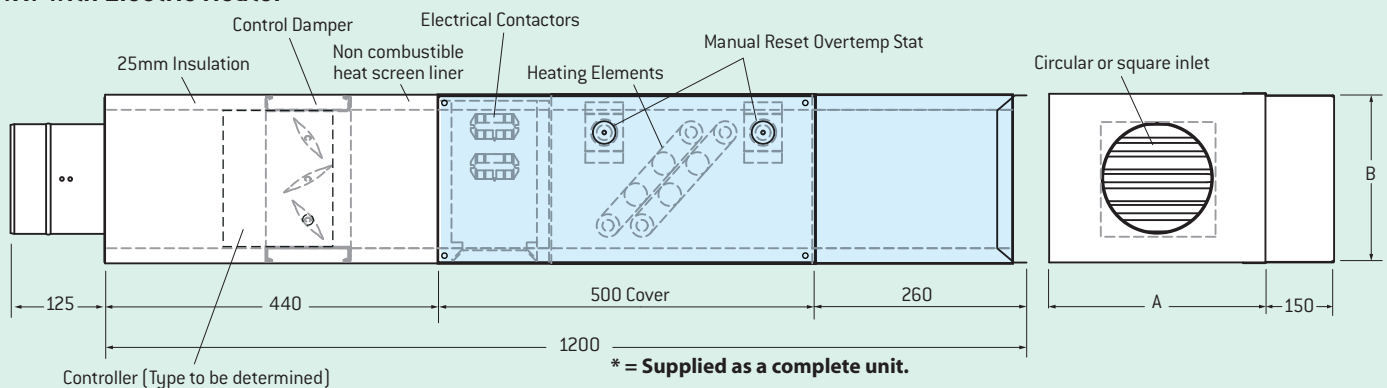

Inlet Dia	Max (kW)	A (mm)	B (mm)
100,125,150	2.5	286	223
175,200,225	3.75	286	296
250	6.0	428	296
300	9.0	428	369
350	12.0	512	398
400	15.0	636	442
600 x 400	15.0	965	442

Note

Maximum kilowatt ratings are guidelines only. Larger ratings can be accommodated.

Hot Water Heating Coil

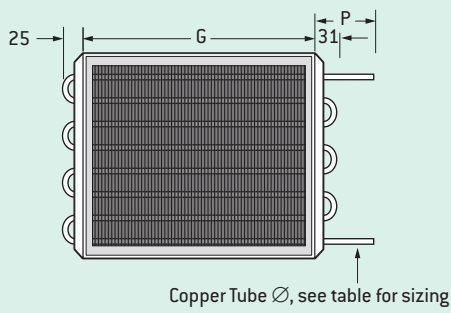

Copper Tube \varnothing , see table for sizing

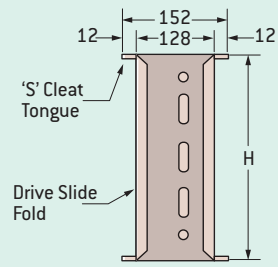

Single Row Single Circuit Illustrated.
Connections Similar But Offset For Others

Australian Manufactured VAV Boxes Only

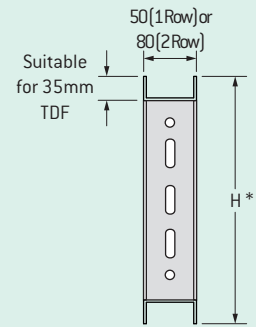

Single Row Single Circuit Illustrated.

Attenuator

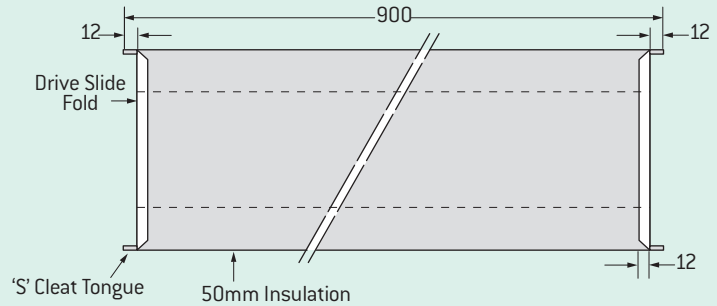
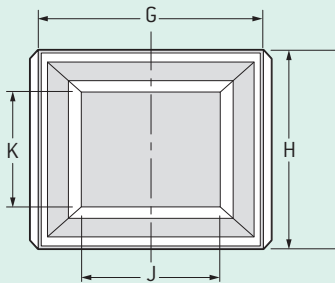

Multi Outlet Adaptor

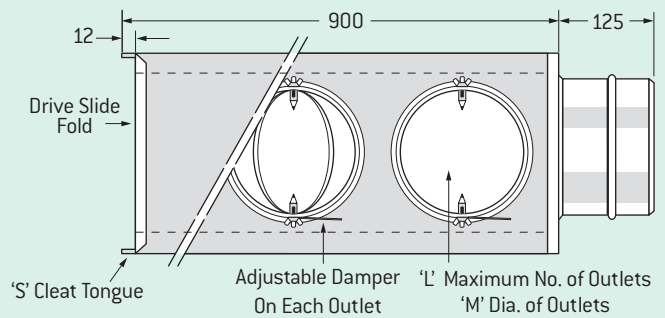
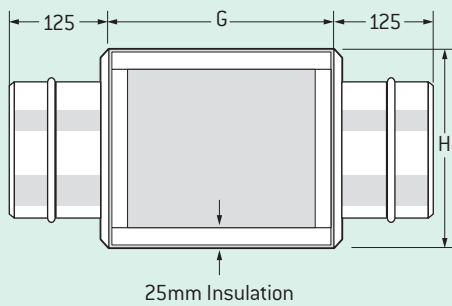

Round Outlet Adaptor

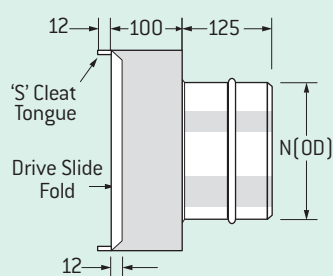
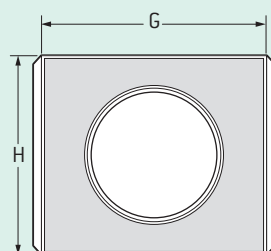

Inlet Attenuator

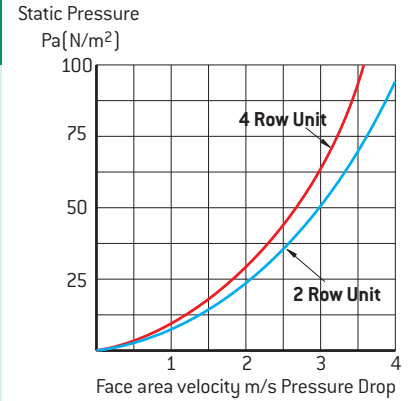
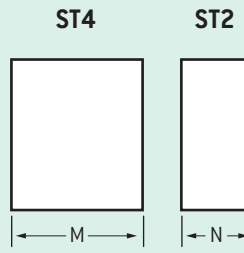
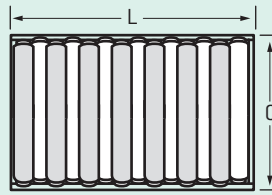
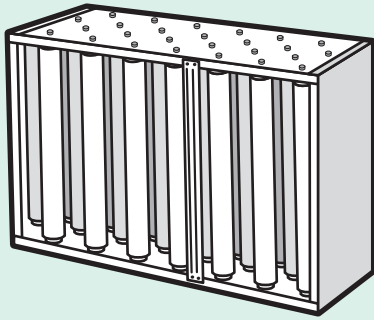

Insertion Loss [dB]								
Frequency Hz	63	125	250	500	1K	2K	4K	8K
2 Row Unit - ST2	0	1	3	5	6	13	8	11
4 Row Unit - ST4	0	1	6	9	12	19	18	15

CASING SIZE	DIMENSION			
	C	L	M	N
A	376	560	400	200
B	376	560	400	200
C	450	560	400	200
D	376	860	400	200
E	450	960	400	200
F	450	1060	400	200

Note See also page 252F, for further data.

Hot Water Coils

CASING SIZES A, B, C & D

ROWS	WATER		Performance [kW]								
	Flow litres/s	Resistance kPa	Air Flow Rate m ³ /s								
			0.400	0.450	0.500	0.550	0.600	0.750	0.800	0.900	1.000
One Row Single Circuit	0.063	0.40	5.67	5.88	6.08	6.27	6.45	6.81	6.92	7.13	7.36
	0.126	1.39	6.96	7.30	7.61	7.91	8.24	8.81	9.02	9.38	9.77
	0.252	4.77	7.85	8.28	8.71	9.10	9.49	10.34	10.61	11.13	11.66
	0.315	7.08	8.06	8.52	8.96	9.39	9.82	10.72	11.03	11.58	12.15
	0.504	16.31	8.42	8.93	9.40	9.88	10.33	11.37	11.72	12.35	13.00
Two Rows Two Circuits	0.063	0.76	8.91	9.23	9.52	9.79	10.06	10.52	10.68	10.91	11.23
	0.126	2.60	11.42	12.01	12.55	13.06	13.55	14.53	14.86	15.41	16.01
	0.252	8.90	13.18	13.98	14.75	15.46	16.18	17.71	18.22	19.10	20.05
	0.315	13.22	13.59	14.45	15.29	16.05	16.86	18.51	19.08	20.06	21.10
	0.504	30.44	14.26	15.22	16.15	17.04	17.89	19.87	20.53	21.70	22.91
0.630	45.23	14.50	15.50	16.48	17.39	18.30	20.38	21.06	22.31	23.59	

CASING SIZES E & F

ROWS	WATER		Performance [kW]								
	Flow litres/s	Resistance kPa	Air Flow Rate m ³ /s								
			0.750	0.800	0.850	0.900	1.000	1.250	1.500	1.750	1.900
One Row Multi-Circuit	0.063	0.20	8.01	8.09	8.25	8.41	8.61	8.94	9.22	9.46	9.64
	0.126	0.69	11.09	11.26	11.59	11.92	12.31	13.05	13.70	14.28	14.66
	0.189	1.43	12.44	12.67	13.08	13.48	14.00	15.01	15.92	16.70	17.22
	0.315	3.55	13.78	14.10	14.61	15.08	15.75	17.11	18.31	19.37	20.06
	0.630	12.14	15.07	15.46	16.06	16.67	17.44	19.18	20.70	22.11	23.00
Two Rows Multi-Circuit	0.063	0.37	11.80	11.89	12.11	12.31	12.51	12.84	13.12	13.35	13.56
	0.126	1.28	17.45	17.70	18.21	18.72	19.26	20.28	21.14	21.85	22.36
	0.189	2.64	20.16	20.54	21.25	21.94	22.73	24.32	25.64	26.80	27.57
	0.315	6.54	22.91	23.45	24.37	25.27	26.43	28.71	30.72	32.49	33.63
	0.630	22.39	25.47	26.19	27.32	28.42	29.95	33.09	35.93	38.46	40.06

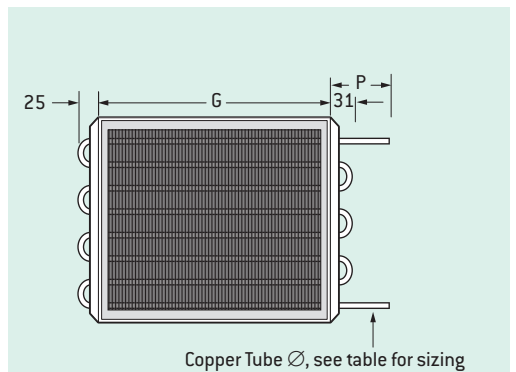

See page 264G for dimensional data

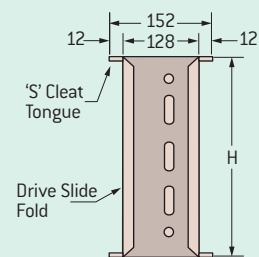

Single Row Single Circuit Illustrated.
Connections Similar But Offset For Others.

Notes

1. Tabulated values are in kW and for hot water only.
2. Data is for the coil type specified (one row-single circuit, two rows-two circuits etc). Data for alternative circuit types are available on request.
3. Tables are based on a temperature difference of 64°K between entering air and entering water. For other temperatures multiply tabulated values by the factors below.
4. Air temperature rise (°K) = kW / (1.2 x m/s).
5. Water temperature drop (°K) = kW / (4.187 x l/s).
6. Connections: Single Circuit 12.7 O.D male solder, Multi-Circuit 22.2 O.D. male solder.

ΔT (°K)	20	30	40	50	60	64	70	80	90
Factors	0.47	0.59	0.71	0.83	0.95	1.00	1.07	1.20	1.31

Radiated Sound Power

SIZE A		*Fan Only					*Min. Inlet SP					125 Pa Inlet					250 Pa Inlet					500 Pa Inlet				
Discharge Static Pa	Flow m ³ /s	125	250	500	1K	2K	125	250	500	1K	2K	125	250	500	1K	2K	125	250	500	1K	2K	125	250	500	1K	2K
75	0.475	60	57	58	50	48	65	62	59	53	52	67	63	60	53	51	67	64	62	54	52	70	68	65	56	56
	0.350	60	50	48	45	40	64	52	46	45	40	65	53	50	46	42	68	61	52	48	46	72	63	55	51	50
	0.250	59	53	48	41	40	61	54	48	42	41	64	57	51	43	43	64	60	53	45	47	68	65	56	49	51
125	0.450	62	59	60	52	50	66	65	62	54	52	67	66	63	53	52	68	67	65	53	54	71	70	67	57	58
	0.300	62	52	50	47	42	63	57	50	48	44	65	57	52	49	46	66	59	54	50	48	70	62	57	52	50
	0.225	61	55	50	43	42	61	52	49	43	42	63	56	52	45	45	64	58	52	46	48	66	61	56	49	52

SIZE B		*Fan Only					*Min. Inlet SP					125 Pa Inlet					250 Pa Inlet					500 Pa Inlet				
Discharge Static Pa	Flow m ³ /s	125	250	500	1K	2K	125	250	500	1K	2K	125	250	500	1K	2K	125	250	500	1K	2K	125	250	500	1K	2K
75	0.500	68	62	54	41	47	73	67	56	54	49	75	67	58	54	50	73	70	59	55	53	78	73	61	57	54
	0.400	66	56	53	49	42	69	60	54	51	43	71	61	56	51	45	68	64	56	52	48	75	67	60	55	50
	0.300	60	54	50	45	41	62	56	50	46	40	65	59	62	47	43	66	65	55	49	47	69	66	59	53	52
125	0.500	70	64	59	50	45	71	66	59	51	46	72	67	57	51	48	72	69	61	52	51	78	73	65	55	53
	0.400	68	61	54	50	43	71	63	55	51	44	72	64	53	50	45	68	67	57	51	48	76	69	60	54	50
	0.300	65	61	52	48	43	68	63	52	49	44	70	64	51	49	45	65	66	55	50	48	73	69	68	53	50

SIZE C		*Fan Only					*Min. Inlet SP					125 Pa Inlet					250 Pa Inlet					500 Pa Inlet				
Discharge Static Pa	Flow m ³ /s	125	250	500	1K	2K	125	250	500	1K	2K	125	250	500	1K	2K	125	250	500	1K	2K	125	250	500	1K	2K
75	0.850	67	63	52	52	47	71	68	57	53	50	72	69	58	54	50	73	70	59	55	51	76	74	64	59	54
	0.700	62	59	51	51	49	65	64	55	51	51	66	65	56	53	52	68	67	59	55	53	71	71	63	59	58
	0.550	59	54	49	48	44	62	59	52	49	45	64	61	55	51	48	66	64	58	55	51	69	67	63	60	57
125	0.850	66	62	55	51	53	69	67	60	52	55	66	65	60	53	56	72	70	63	54	57	75	73	67	58	60
	0.700	61	59	54	52	59	64	63	57	52	60	66	65	59	54	62	68	68	62	56	64	71	71	66	61	68
	0.550	58	57	47	48	45	61	61	50	49	45	63	63	52	52	48	65	66	56	55	51	69	70	61	60	56

SIZE D		*Fan Only					*Min. Inlet SP					125 Pa Inlet					250 Pa Inlet					500 Pa Inlet				
Discharge Static Pa	Flow m ³ /s	125	250	500	1K	2K	125	250	500	1K	2K	125	250	500	1K	2K	125	250	500	1K	2K	125	250	500	1K	2K
75	0.850	59	68	56	54	49	63	73	61	55	52	64	74	62	56	52	65	75	63	57	53	68	79	68	61	56
	0.700	57	59	54	51	41	60	64	58	51	43	61	65	59	53	44	63	67	62	55	45	66	71	66	59	50
	0.550	56	54	53	46	39	59	59	56	47	40	61	61	59	49	43	63	64	62	53	46	66	67	67	58	52
125	0.850	62	60	63	59	56	65	65	68	60	58	66	66	68	61	59	68	68	71	62	60	71	71	75	66	63
	0.700	60	61	57	60	56	63	65	60	60	57	65	67	62	62	59	67	70	65	64	61	70	73	69	69	65
	0.550	59	61	58	59	55	62	65	61	60	55	64	67	63	63	58	66	70	67	66	61	70	74	72	71	66

SIZE E		*Fan Only					*Min. Inlet SP					125 Pa Inlet					250 Pa Inlet					500 Pa Inlet				
Discharge Static Pa	Flow m ³ /s	125	250	500	1K	2K	125	250	500	1K	2K	125	250	500	1K	2K	125	250	500	1K	2K	125	250	500	1K	2K
75	1.600	73	67	64	59	56	77	72	69	60	59	78	73	70	61	59	79	74	71	62	60	82	78	76	66	63
	1.450	64	68	63	58	51	67	73	67	58	53	68	74	68	60	54	70	76	71	62	55	73	80	75	66	60
	1.200	61	66	61	53	49	64	71	64	54	50	66	73	67	56	53	68	76	70	60	56	71	79	75	65	62
125	1.600	76	66	67	64	63	79	71	72	65	65	80	72	72	66	66	82	74	75	67	67	85	77	79	71	70
	1.450	70	67	66	67	66	73	71	69	67	67	75	73	71	69	69	77	76	74	71	71	80	79	78	76	75
	1.200	69	68	66	68	65	72	72	69	69	65	74	74	71	72	68	76	77	75	75	71	80	81	80	80	76

SIZE F		*Fan Only					*Min. Inlet SP					125 Pa Inlet					250 Pa Inlet					500 Pa Inlet				
Discharge Static Pa	Flow m ³ /s	125	250	500	1K	2K	125	250	500	1K	2K	125	250	500	1K	2K	125	250	500	1K	2K	125	250	500	1K	2K
75	2.180	75	68	62	57	51	79	73	67	58	54	80	74	68	59	54	81	75	69	60	55	84	79	74	64	58
	1.920	68	67	63	59	51	71	72	67	59	53	72	73	68	61	54	74	75	71	63	55	77	79	75	67	60
	1.480	63	67	62	54	51	66	72	65	55	52	68	74	68	57	55	70	77	71	61	58	73	80	76	66	64
125	2.180	78	67	65	62	58	81	72	70	63	60	82	73	70	64	61	84	75	73	65	62	87	78	77	69	65
	1.920	74	69	66	68	66	77	73	69	68	67	79	75	71	70	69	81	78	74	72	71	84	81	78	77	75
	1.480	71	69	67	69	67	74	73	70	70	67	76	75	72	73	70	78	78	76	76	73	82	82	81	81	78

Notes

1. Sound Power levels are expressed in decibels = Lw & 10⁻¹² Watts.
2. Above data does not include allowance for ceiling transmission loss, room absorption, or duct attenuation.
3. Sound power levels shown are for Primary flow = Total flow. These levels decrease as the percentage of primary flow reduces, until a minimum is reached at "fan only" where Secondary flow = Total flow.

* Flow at these conditions may rise by up to 10 percent above listed values. (See also variations caused by different discharge static pressures).

Discharge Sound Power

SIZE A						
Flow m ³ /s	Disch. Press. Pa	Octave Band				
		125	250	500	1K	2K
0.170	100	61	54	48	49	41
0.360	50	59	43	47	46	46
0.447	20	57	57	58	61	57

SIZE B						
Flow m ³ /s	Disch. Press. Pa	Octave Band				
		125	250	500	1K	2K
0.195	300	65	54	53	57	55
0.530	200	69	52	56	57	56
0.720	20	77	58	60	63	61

SIZE C						
Flow m ³ /s	Disch. Press. Pa	Octave Band				
		125	250	500	1K	2K
0.600	330	65	65	64	66	63
0.800	250	70	65	64	66	63
1.000	20	71	64	67	68	64

SIZE D						
Flow m ³ /s	Disch. Press. Pa	Octave Band				
		125	250	500	1K	2K
0.800	200	60	58	58	60	58
0.850	130	58	56	56	59	55
0.720	20	61	54	56	58	53

SIZE E						
Flow m ³ /s	Disch. Press. Pa	Octave Band				
		125	250	500	1K	2K
1.200	350	66	66	64	65	63
1.450	250	68	67	65	66	65
1.600	20	76	64	66	65	65

SIZE F						
Flow m ³ /s	Disch. Press. Pa	Octave Band				
		125	250	500	1K	2K
1.450	350	68	67	65	66	65
1.920	250	72	66	65	67	65
2.180	20	78	61	64	63	60

Refer to Performance Notes on previous page.

Due to a policy of continuous development and improvement the right is reserved to supply products which may differ slightly from those illustrated and described in this publication.

HFC – Fan Assisted VAV Terminals

Suggested Specifications

Fan assisted VAV assemblies shall be Holyoake Type (HFCS-Variable Flow, HFCS-Constant Flow) supplied with or without controls, matching factory furnished accessories (electric heater, HW heater coil, inlet/outlet attenuator, outlet adapter) and secondary air filter, as shown elsewhere in this specification or on the drawings. Primary air flow shall be pressure independent and capable of temperature controlled velocity re-set between zero and maximum catalogued air flow.

Primary air valves shall consist of extruded aluminium blades on stainless steel shafts in acetal anti-rotation bearings, mounted in a 0.75 galv. mild steel high pressure enclosure with PDI type averaging flow sensor in the inlet. The leakage of the high pressure enclosure with closed damper shall not exceed 2% of maximum rated primary flow at 750 Pa inlet static pressure. Secondary air fans shall be statically and dynamically balanced, with resiliently mounted,

electronically speed controlled, permanently lubricated motors.

Fan and valve shall be mounted in a single casing of 0.75 galv. steel. No internal components shall be fixed to the bottom panel which shall be completely removable. The casing shall be internally insulated with a minimum of 25 mm non-woven acoustic polyester insulation and all shall be as manufactured by Holyoake.

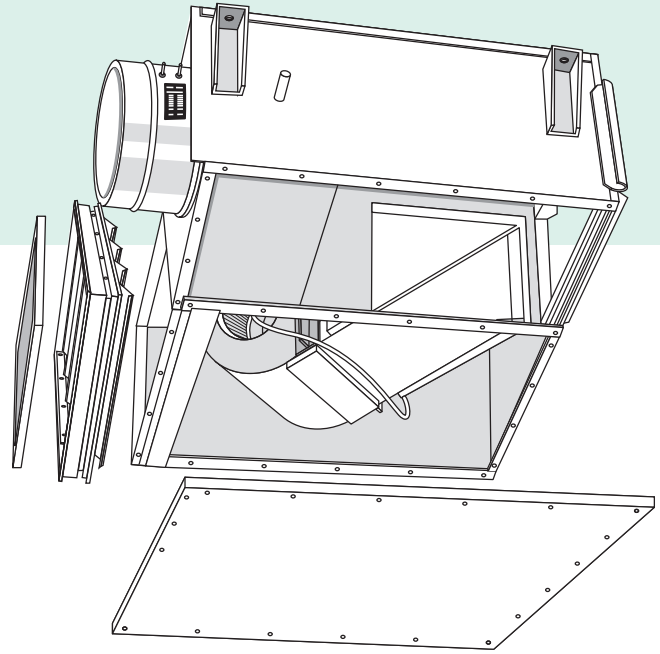

Model: Number Key

Parallel HFCS
Series HFCS

See Page 287G

See Page 289G