

BDE – Back Draft Damper

Model: BDE

The Holyoke Model BDE is a light duty pressure relief damper constructed of extruded aluminium.

It operates at low opening pressure differential and with minimal leakage when closed against reverse flow.

Standard Construction

Frame Options:

- (1) Front flange mounting (Small).
- (2) Rear flange mounting (Small).
- (3) Channel frame: Flange is removed for channel mounting.
- (4) Duct flange: For connecting to a 25 mm proprietary flange system.
- (5) Front flange mounting (Large).
- (6) Rear flange mounting (Large).

Blades: 6063 T5 extruded aluminium with flexible vinyl blade edge seal (0-80°C).

Linkage Bar: 1.6 x 13 mm aluminium bar, fixed to all blades at one end, to avoid flutter.

Axles & Cranks: Moulded acetal, (-8-+120°C) left and right handed with integral pivot pins for both blade support and interconnecting linkage.

Finish: Mill.

Minimum Size: 150 mm Wide x 150 mm High Nominal Duct Size.

Maximum Size: 1000 mm Wide x 1140 mm High Nominal Duct Size, (Single Section).

Maximum Velocity: 5 m/s AVERAGE, 7.5 m/s SPOT

Options (at additional cost):

Tensions Springs: (A) Normal. Tension spring to provide **adjustable resistance** to airflow.

(B) Inverted. Tension spring to provide **adjustable resistance** to airflow. Blades reversed.

(C) Horizontal. Tension spring to provide **adjustable opening assistance** when used in the horizontal plane for upward airflow.

Not available for downward airflow.

Features

- Aluminium Construction
- Vertical, or Horizontal mounting (Blades must always be horizontal).
- Vinyl blade edge seal.
- Linked blades, to avoid flutter.
- Gravity operation.

Options

- Duct flange, or Channel frame.
- Front, or Rear Flange.
- Large, or Small Flange.
- Tension Springs.

Back Draft Damper

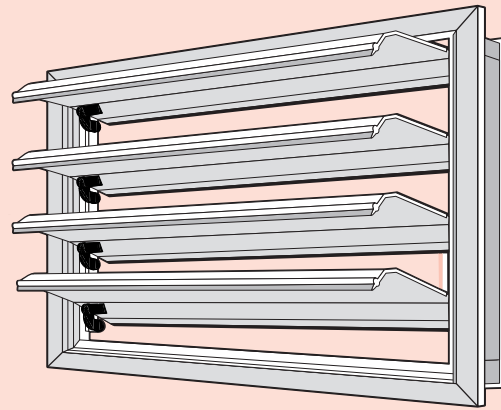

Pressure Relief

When used as a pressure relief device, there are two orientation options, vertical and horizontal, neither requiring resistance springs.

However, on horizontal units, tension springs can be added to provide adjustable opening assistance for upwards airflow, to help overcome the additional blade weight incurred in that position. Factory calibration is not available and these units are only for adjustment in the field by the purchaser.

Although not a precision device, the Holyoke BDE can provide a simple solution to pressure relief problems, within the parameters indicated in the Standard Vertical Orientation data.

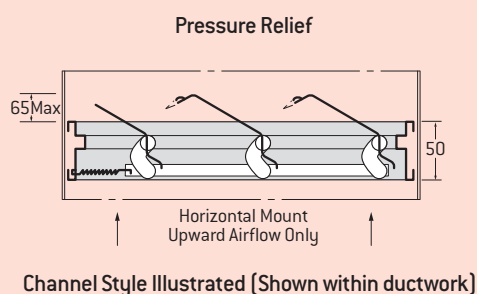
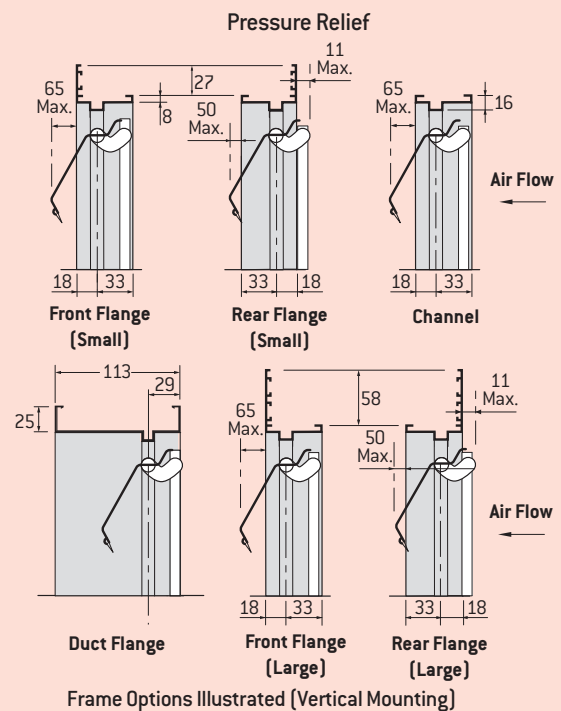

Model: **BDE**

Pressure Control

When used as an upstream pressure control device, there are two orientation options, both vertical and both using resistance springs.

Normal: Maximum opening static pressure is adjustable between 50 and 100 Pa at maximum flow. Pressure tends to vary with flow.

Inverted: Maximum opening static pressure is adjustable between 19 and 66 Pa. Pressure tends to remain constant as flow varies.

The Holyoake BDE is not a precision device and factory calibration is not available. These units are only for adjustment in the field by the purchaser. However, they can provide a simple solution to pressure control problems within the parameters indicated in the relevant performance data.

Before ordering for pressure control, consult your local Holyoake branch. It is important that only complete blade modules are used, with trailing edges intact.

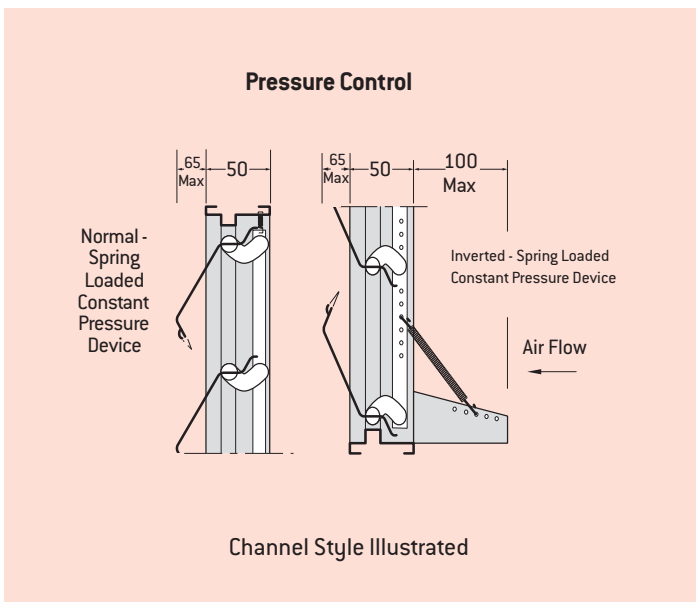
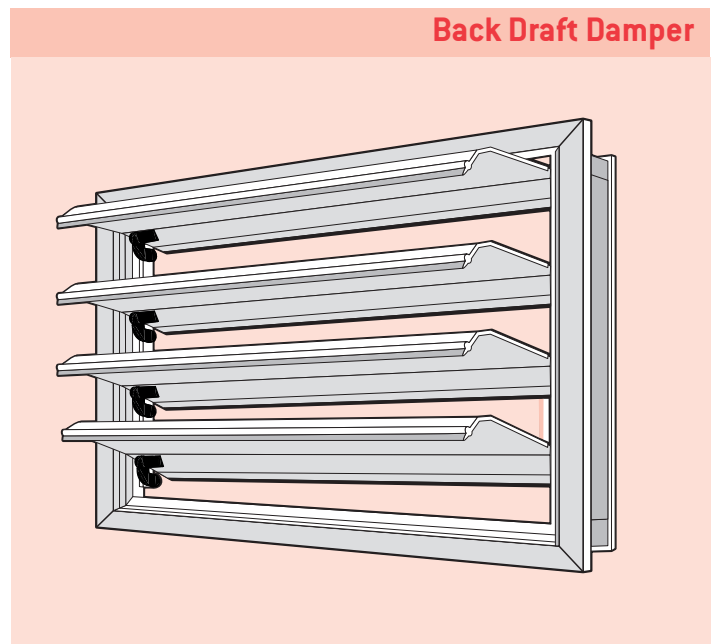

BDE shutters must not be installed with the axles vertical.

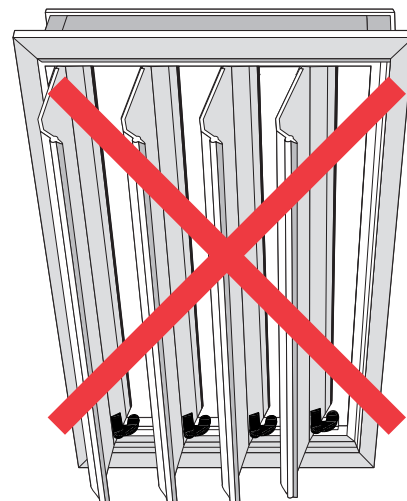

Installation

When ordering, Nominal duct dimensions are required, Width (Blade Length) x Height.

A 7 mm clearance is allowed in manufacture to enable dampers to be inserted within ductwork, (except Duct Flange units which are Nominal Airstream Sizes).

Where used in fan discharge applications, allow adequate distance for turbulence to reduce, e.g. for axial flow fans, or for centrifugal fans, mount five impeller diameters downstream from the fan outlet.

Install square and free from racking.

Do not rely upon BDE back draft dampers for weather resistance. Where required in an outside wall, use in conjunction with OHL series weather louvers.

Guide Product Weights	
BDE Back Draft Damper	Approximate Weight in Kg
300 x 300 (Small Channel)	1.02
1000 x 1000 (Small Channel)	11.33 per m ²

Mounted in Vertical Position in Standard Orientation

Duct Height (mm)	Flowrate (l/s)	Nom duct Vel (m/s)	No Spring P _s (Pa)	Spring Pos for Max Tension P _s (Pa)	FLOWRATE (l/s)				
					Duct Width (mm)				
					150	250	500	750	1000
150	Min	0.2	10	30	5	8	15	23	30
	Max	5.0	50	100	113	188	375	563	750
240	Min	0.2	10	30	7	12	24	36	48
	Max	5.0	50	100	180	300	600	900	1200
340	Min	0.2	10	30	10	17	34	51	68
	Max	5.0	50	100	255	425	850	1275	1700
440	Min	0.2	10	30	13	22	44	66	88
	Max	5.0	50	100	330	550	1100	1650	2200
540	Min	0.2	10	30	16	27	54	81	108
	Max	5.0	50	100	405	675	1350	2025	2700
640	Min	0.2	10	30	19	32	64	96	128
	Max	5.0	50	100	480	800	1600	2400	3200
740	Min	0.2	10	30	22	37	74	111	148
	Max	5.0	50	100	555	925	1850	2775	3700
840	Min	0.2	10	30	25	42	84	126	168
	Max	5.0	50	100	630	1050	2100	3150	4200
940	Min	0.2	10	30	28	47	94	141	188
	Max	5.0	50	100	705	1175	2350	3525	4700
1040	Min	0.2	10	30	31	52	104	156	208
	Max	5.0	50	100	780	1300	2600	3900	5200
1140	Min	0.2	10	30	34	57	114	171	228
	Max	5.0	50	100	855	1425	2850	4275	5700

Mounted in Vertical Position in Inverted Orientation

Duct Height (mm)	Flowrate (l/s)	Nom duct Vel (m/s)	Spring Pos for Min Tension P _s (Pa)	Spring Pos for Max Tension P _s (Pa)	FLOWRATE (l/s)				
					Duct Width (mm)				
					150	250	500	750	1000
150	Min	0.2	19	40	5	8	15	23	30
	Max ¹	3.3	25		74	124	248	371	495
	Max	5.0		66	113	188	375	563	750
240	Min	0.2	19	40	7	12	24	36	48
	Max ¹	3.3	25		119	198	396	594	792
	Max	5.0		66	180	300	600	900	1200
340	Min	0.2	19	40	10	17	34	51	68
	Max ¹	3.3	25		168	281	561	842	1122
	Max	5.0		66	255	425	850	1275	1700
440	Min	0.2	19	40	13	22	44	66	88
	Max ¹	3.3	25		218	363	726	1089	1452
	Max	5.0		66	330	550	1100	1650	2200
540	Min	0.2	19	40	16	27	54	81	108
	Max ¹	3.3	25		267	446	891	1337	1782
	Max	5.0		66	405	675	1350	2025	2700
640	Min	0.2	19	40	19	32	64	96	128
	Max ¹	3.3	25		317	528	1056	1584	2112
	Max	5.0		66	480	800	1600	2400	3200
740	Min	0.2	19	40	22	37	74	111	148
	Max ¹	3.3	25		366	611	1221	1832	2442
	Max	5.0		66	555	925	1850	2775	3700
840	Min	0.2	19	40	25	42	84	126	168
	Max ¹	3.3	25		416	693	1386	2079	2772
	Max	5.0		66	630	1050	2100	3150	4200
940	Min	0.2	19	40	28	47	94	141	188
	Max ¹	3.3	25		465	776	1551	2327	3102
	Max	5.0		66	705	1175	2350	3525	4700
1040	Min	0.2	19	40	31	52	104	156	208
	Max ¹	3.3	25		515	858	1716	2574	3432
	Max	5.0		66	780	1300	2600	3900	5200
1140	Min	0.2	19	40	34	57	114	171	228
	Max ¹	3.3	25		564	941	1881	2822	3762
	Max	5.0		66	855	1425	2850	4275	5700

¹ Blades are fully open at 3.3 m/s. Note: Velocities at nominal (approach duct) area.

Product Ordering Key and Suggested Specifications

BDE	FRAME STYLE	W x H	OPTIONS
Back Draft Damper with Extruded Blade	C - Channel Frame DF - Duct Flange FFL - Front Flange - Large FFS - Front Flange - Small RFL - Rear Flange - Large RFS - Rear Flange - Small	Nominal Duct Size	Tension Springs [Normal, Inverted, or Horizontal]

Back Draft Dampers shall be constructed from extruded aluminium.

Frames shall have mitred corners, be mechanically locked with aluminium gussets and be suitable for internal fixing within ductwork, or have square cut ends and be mechanically joined with screws tapped into screw pipes, for external duct flange mounting.

Blades shall be extruded aluminium with vinyl edge seal and shall be freely pivoted in the frame on moulded acetal cranks and bearing pins, linked by a gang bar, to operate in unison.

All shall be type BDE as manufactured by Holyoake.

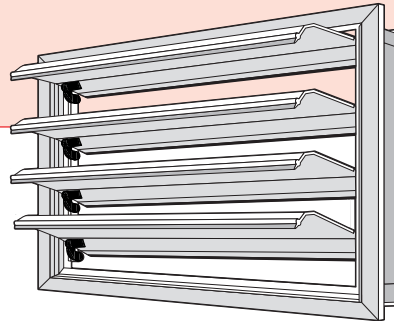

PRD150	FRAME STYLE	W x H	Pa	OPTIONS
Heavy Duty Pressure Relief Damper	C - Channel Frame * DF - Duct Flange +	Nominal Overall Case Size* Nominal Duct Size (Airstream)+	Opening Pressure Required	Lever Arm and Blade Weights. High Temperature Version (Max 210C).

Heavy Duty Pressure Relief Dampers shall be constructed from extruded aluminium.

Frames shall have mitred corners, be mechanically locked with aluminium gussets and be suitable for internal fixing within ductwork, or have square cut ends and be mechanically joined with screws tapped into screw pipes, for external duct flange mounting.

Blades shall be extruded aluminium with acetal edge seals both sides and be complete with aluminium side seal gaskets. They shall be linked by an aluminium gang bar, to operate together in unison. They shall freely pivot in the frame, on aluminium cranks and axles, within moulded acetal bearings. (Blade adjustment weights may be added if required, via a spindle control bar).

All shall be type PRD 150 as manufactured by Holyoake.

